

MULTILAYER CERAMIC CHIP CAPACITOR

- GMX SERIES - SOFT TERMINATION

INTRODUCTION

- Multilayer Ceramic Chip Capacitors supplied in bulk or tape & reel package are ideally suitable for thick-film hybrid circuits and automatic surface mounting on any printed circuit boards.
- GMX series use a special material between nickel-barrier and ceramic body. It provides excellent performance to guard against bending stress occurred during process and provide more security for PCB process.
- The nickel-barrier terminations are consisted of a nickel barrier layer over the silver metalization and then finished by electroplated solder layer to ensure the terminations have good solderability. The nickel barrier layer in terminations prevents the dissolution of termination when extended immersion in molten solder at elevated solder temperature.

EXTERNAL DIMENSION

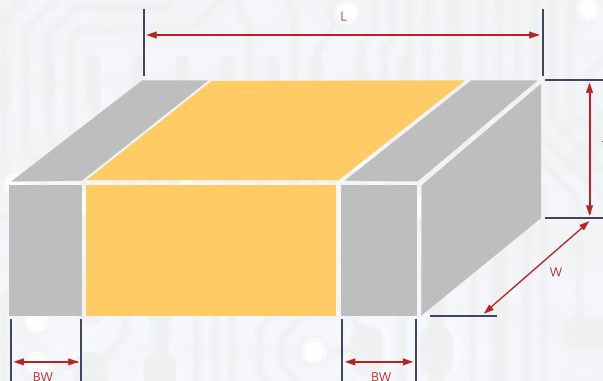

APPLICATIONS

- For general digital circuit.
- For power supply bypass capacitors.
- For consumer electronics.
- For telecommunication.
- DC to DC converter.

FEATURES

- High performance to withstanding 3~5mm of substrate bending test guarantee.
- A wide selection of sizes is available.
- High capacitance in given case size.
- Capacitor with lead-free termination (pure Tin).
- Reduction in PCB bend failure.
- High reliability and stability.
- RoHS & HALOGEN FREE.

ORDERING INFORMATION

GMX	31	X7R	104	K	100	CT
SERIES	SIZE	DIELECTRIC	CAPACITANCE	TOLERANCE	RATED VOLTAGE	PACKAGING
Anti-Bend General Purpose Product	04 - 0402 (1005) 10 - 0603 (1608) 21 - 0805 (2012) 31 - 1206 (3216) 32 - 1210 (3225) 40 - 1808 (4520) 43 - 1812 (4532) 45 - 1825 (4563) 55 - 2220 (5750) 57 - 2225 (5763)	CG - COG X7R - X7R X7S - X7S X5R - X5R	R47 - 0.47pF OR5 - 0.5pF 100 - 10x10 ⁻¹⁰ pF 102 - 10x10 ⁻¹⁰ 100pF 104 - 10x10 ⁻¹⁰ 100nF 106 - 10x10 ⁻¹⁰ 10μF	A: ±0.05pF B: ±0.10pF C: ±0.25 pF D: ±0.50 pF F: ±1 % G: ±2% H: ±3% I : -10% ~ 0% J : ±5% K: ±10% L : 0% ~ +10% M: ±20% N: -5% ~ +10% P: ±0.02 pF Q: ±0.03 pF Z : -20% ~ +80% X: +10% ~ +20%	6R3 - 6.3Vdc 10 - 10Vdc 16 - 16Vdc 25 - 25Vdc 35 - 35Vdc 50 - 50Vdc 100 - 100Vdc 200 - 200Vdc 250 - 250Vdc 400 - 400Vdc 500 - 500Vdc 630 - 630Vdc 1K0 - 1000Vdc 1K5 - 1500Vdc 2K0 - 2000Vdc 3K0 - 3000Vdc 4K0 - 4000Vdc 5K0 - 5000Vdc	CT -Tape and 7" Reel CTD - Tape and 10" Reel CTG - Tape and 13" Reel

UNIT: MM

SIZE	INCH	L	W	t	BW
0402	1005	1.00±0.20	0.50±0.20	SEE TABLE BELOW	0.25 +0.05/-0.10
0603	1608	1.60±0.20	0.80±0.20		0.40±0.15
0805	2012	2.10±0.20	1.25±0.20		0.50±0.20
1206	3216	3.30±0.30	1.60±0.20 1.60 +0.30/-0.10		0.60±0.20
1210	3225	3.30±0.40	2.50±0.30		0.75±0.35
1808	4520	4.60±0.50	2.00±0.25		0.75±0.35
1812	4532	4.60±0.50	3.20±0.30		0.75±0.35
1825	4563	4.60±0.50	6.30±0.40		0.75±0.35
2220	5750	5.70±0.50	5.00±0.40		0.85±0.35
2225	5763	5.70±0.50	6.30±0.40		0.85±0.35



GENERAL ELECTRICAL DATA

DIELECTRIC	C0G	X7R	X7S	X5R																								
SIZE	0402, 0603, 0805, 1206, 1210, 1808, 1812, 1825, 2220, 2225	0402, 0603, 0805, 1206, 1210, 1808, 1812, 1825, 2220, 2225	0402, 0603, 0805, 1206, 1210, 2220	0402, 0603, 0805, 1206, 1210																								
RATED VOLTAGE (WVDC)	10V, 16V, 25V, 50V, 100V, 200V, 250V, 500V, 630V, 1KV, 1.5KV, 2KV, 3KV, 4KV	6.3V, 10V, 16V, 25V, 50V, 100V, 200V, 250V, 500V, 630V, 1KV, 1.5KV, 2KV, 3KV, 4KV, 5KV	6.3V, 10V, 16V, 25V, 50V, 100V, 2KV	6.3V, 10V, 16V, 25V, 50V, 100V, 200V, 250V, 500V, 630V, 1KV, 1.5KV, 2KV, 3KV, 4KV, 5KV																								
CAPACITANCE RANGE	0.1pF ~ 100nF	100pF ~ 47μF	470PF-47UF	0.033uF ~ 100uF																								
CAPACITANCE TOLERANCE	SEE ORDERING INFORMATION																											
TAN δ	<table border="1"> <tr> <th>CAP. RANGE</th> <th>Q SPEC</th> </tr> <tr> <td>CAP. <30pF</td> <td>Q_z400+20°C</td> </tr> <tr> <td>CAP. ≥30pF</td> <td>Q_z1000</td> </tr> </table>	CAP. RANGE	Q SPEC	CAP. <30pF	Q _z 400+20°C	CAP. ≥30pF	Q _z 1000	SEE RELIABILITY TEST CONDITIONS AND REQUIREMENTS BELOW																				
CAP. RANGE	Q SPEC																											
CAP. <30pF	Q _z 400+20°C																											
CAP. ≥30pF	Q _z 1000																											
CAPACITANCE & TAN δ TEST CONDITION	For 25°C at ambient temperature		Preconditioning for Class II MLCC: Perform a heat treatment at 150±10°C for 1 hour, then leave in ambient condition for 24±2 hours before measurement																									
	<table border="1"> <thead> <tr> <th>CAP. RANGE</th> <th>TEST CONDITION</th> </tr> </thead> <tbody> <tr> <td>Cap. ≤1000pF</td> <td>1.0±0.2Vrms, 1.0MHz±10%</td> </tr> <tr> <td>Cap. >1000pF</td> <td>1.0±0.2Vrms, 1.0KHz±10%</td> </tr> </tbody> </table>	CAP. RANGE	TEST CONDITION	Cap. ≤1000pF	1.0±0.2Vrms, 1.0MHz±10%	Cap. >1000pF	1.0±0.2Vrms, 1.0KHz±10%	<table border="1"> <thead> <tr> <th>CAP. RANGE</th> <th>TEST CONDITION</th> </tr> </thead> <tbody> <tr> <td>Cap. ≤10μF</td> <td>1.0±0.2Vrms, 1.0KHz±10%</td> </tr> <tr> <td>Cap. >10μF</td> <td>0.5±0.2Vrms, 120Hz±20%</td> </tr> </tbody> </table>	CAP. RANGE	TEST CONDITION	Cap. ≤10μF	1.0±0.2Vrms, 1.0KHz±10%	Cap. >10μF	0.5±0.2Vrms, 120Hz±20%	<table border="1"> <thead> <tr> <th>CAP. RANGE</th> <th>TEST CONDITION</th> </tr> </thead> <tbody> <tr> <td>Cap. ≤10μF</td> <td>1.0±0.2Vrms, 1.0KHz±10%</td> </tr> <tr> <td>Cap. >10μF</td> <td>0.5±0.2Vrms, 120Hz±20%</td> </tr> </tbody> </table>	CAP. RANGE	TEST CONDITION	Cap. ≤10μF	1.0±0.2Vrms, 1.0KHz±10%	Cap. >10μF	0.5±0.2Vrms, 120Hz±20%	<table border="1"> <thead> <tr> <th>CAP. RANGE</th> <th>TEST CONDITION</th> </tr> </thead> <tbody> <tr> <td>Cap. ≤10μF</td> <td>1.0±0.2Vrms, 1.0KHz±10%</td> </tr> <tr> <td>Cap. >10μF</td> <td>0.5±0.2Vrms, 120Hz±20%</td> </tr> </tbody> </table>	CAP. RANGE	TEST CONDITION	Cap. ≤10μF	1.0±0.2Vrms, 1.0KHz±10%	Cap. >10μF	0.5±0.2Vrms, 120Hz±20%
	CAP. RANGE	TEST CONDITION																										
Cap. ≤1000pF	1.0±0.2Vrms, 1.0MHz±10%																											
Cap. >1000pF	1.0±0.2Vrms, 1.0KHz±10%																											
CAP. RANGE	TEST CONDITION																											
Cap. ≤10μF	1.0±0.2Vrms, 1.0KHz±10%																											
Cap. >10μF	0.5±0.2Vrms, 120Hz±20%																											
CAP. RANGE	TEST CONDITION																											
Cap. ≤10μF	1.0±0.2Vrms, 1.0KHz±10%																											
Cap. >10μF	0.5±0.2Vrms, 120Hz±20%																											
CAP. RANGE	TEST CONDITION																											
Cap. ≤10μF	1.0±0.2Vrms, 1.0KHz±10%																											
Cap. >10μF	0.5±0.2Vrms, 120Hz±20%																											
INSULATION RESISTANCE																												
≥10GΩ or RxC≥500Ω-F, whichever is smaller																												
OPERATING TEMPERATURE	-55°C to + 125°C	-55°C to + 125°C	-55°C to + 125°C	-55°C to + 85°C																								
TEMPERATURE COEFFICIENT	±30ppm/°C	±15%	±22%	±15%																								
TERMINATION	Cu/Ag polymer/Ni/Sn (lead-free termination)																											





CAPACITANCE RANGE

DIELECTRIC			COG																						
SIZE			0402					0603					0805												
RATED VOLTAGE			10	16	25	50	100	10	16	25	50	100	200	250	10	16	25	50	100	200	250	500	630	1000	
CAPACITANCE RANGE	0.1pF	0R1	G	G	G	G																			
	0.2pF	0R2	G	G	G	G																			
	0.3pF	0R3	G	G	G	G		I	I	I	I	I													
	0.4pF	0R4	G	G	G	G		I	I	I	I	I													
	0.5pF	0R5	G	G	G	G	G	I	I	I	I	I	I	I	H	H	H	H	H	H	H	H	H	H	N
	0.6pF	0R6	G	G	G	G	G	I	I	I	I	I	I	I	H	H	H	H	H	H	H	H	H	H	N
	0.7pF	0R7	G	G	G	G	G	I	I	I	I	I	I	I	H	H	H	H	H	H	H	H	H	H	N
	0.8pF	0R8	G	G	G	G	G	I	I	I	I	I	I	I	H	H	H	H	H	H	H	H	H	H	N
	0.9pF	0R9	G	G	G	G	G	I	I	I	I	I	I	I	H	H	H	H	H	H	H	H	H	H	N
	1.0pF	1R0	G	G	G	G	G	I	I	I	I	I	I	I	H	H	H	H	H	H	H	H	H	H	N
	1.2pF	1R2	G	G	G	G	G	I	I	I	I	I	I	I	H	H	H	H	H	H	H	H	H	H	N
	1.5pF	1R5	G	G	G	G	G	I	I	I	I	I	I	I	H	H	H	H	H	H	H	H	H	H	N
	1.8pF	1R8	G	G	G	G	G	I	I	I	I	I	I	I	H	H	H	H	H	H	H	H	H	H	N
	2.2pF	2R2	G	G	G	G	G	I	I	I	I	I	I	I	H	H	H	H	H	H	H	H	H	H	N
	2.7pF	2R7	G	G	G	G	G	I	I	I	I	I	I	I	H	H	H	H	H	H	H	H	H	H	N
	3.3pF	3R3	G	G	G	G	G	I	I	I	I	I	I	I	H	H	H	H	H	H	H	H	H	H	N
	3.9pF	3R9	G	G	G	G	G	I	I	I	I	I	I	I	H	H	H	H	H	H	H	H	H	H	N
	4.7pF	4R7	G	G	G	G	G	I	I	I	I	I	I	I	H	H	H	H	H	H	H	H	H	H	N
	5.6pF	5R6	G	G	G	G	G	I	I	I	I	I	I	I	H	H	H	H	H	H	H	H	H	H	N
	6.2pF	6R2	G	G	G	G	G	I	I	I	I	I	I	I	H	H	H	H	H	H	H	H	H	H	N
	6.8pF	6R8	G	G	G	G	G	I	I	I	I	I	I	I	H	H	H	H	H	H	H	H	H	H	N
	8.2pF	8R2	G	G	G	G	G	I	I	I	I	I	I	I	H	H	H	H	H	H	H	H	H	H	N
	10pF	100	G	G	G	G	G	I	I	I	I	I	I	I	H	H	H	H	H	H	H	H	H	H	N
	12pF	120	G	G	G	G	G	I	I	I	I	I	I	I	H	H	H	H	H	H	H	H	H	H	N
	15pF	150	G	G	G	G	G	I	I	I	I	I	I	I	H	H	H	H	H	H	H	H	H	H	N
	18pF	180	G	G	G	G	G	I	I	I	I	I	I	I	H	H	H	H	H	H	H	H	H	H	N
	22pf	220	G	G	G	G	G	I	I	I	I	I	I	I	H	H	H	H	H	H	H	H	H	H	N
	27pf	270	G	G	G	G	G	I	I	I	I	I	I	I	H	H	H	H	H	H	H	H	H	H	N
	33pf	330	G	G	G	G	G	I	I	I	I	I	I	I	H	H	H	H	H	H	H	H	H	H	N
	39pf	390	G	G	G	G	G	I	I	I	I	I	I	I	H	H	H	H	H	H	H	H	H	H	N
	47pf	470	G	G	G	G	G	I	I	I	I	I	I	I	H	H	H	H	H	H	H	H	H	H	N
	56pf	560	G	G	G	G	G	I	I	I	I	I	I	I	H	H	H	H	H	H	H	H	H	H	N
	68pf	680	G	G	G	G	G	I	I	I	I	I	I	I	H	H	H	H	H	H	H	H	H	H	N
	82pf	820	G	G	G	G	G	I	I	I	I	I	I	I	H	H	H	H	H	H	H	H	X	X	N
	100pf	101	G	G	G	G	G	I	I	I	I	I	I	I	H	H	H	H	H	H	H	X	X	X	N
	120pf	121	G	G	G	G	G	I	I	I	I	I	I	I	H	H	H	H	H	H	H	X	N	N	N
	150pf	151	G	G	G	G	G	I	I	I	I	I	I	I	H	H	H	H	H	H	X	X	N	N	N
	180pf	181	G	G	G	G	G	I	I	I	I	I	I	I	H	H	H	H	H	X	N	N	N	N	N
	220pf	221	G	G	G	G	G	I	I	I	I	I	I	I	H	H	H	H	H	N	N	N	N	N	N
	270pf	271	G	G	G	G		I	I	I	I	I	G	G	H	H	H	H	H	N	N	N	N	N	N
	330pf	331	G	G	G	G		I	I	I	I	I	G	G	H	H	H	H	H	N	N	N	N	N	N
	390pF	391	G	G	G	G		I	I	I	I	I	G	G	X	X	X	X	X	N	N	N	N	N	N
	470pf	471	G	G	G	G		I	I	I	I	I	G	G	X	X	X	X	X	N	N	R	R		
	560pf	561	G	G	G	G		I	I	I	I	I			X	X	X	X	X	N	N	R	R		
	680pf	681	G	G	G	G		I	I	I	I	I			X	X	X	X	X	N	N	R	R		
820pf	821	G	G	G	G		I	I	I	I	I			X	X	X	X	X	N	N	R	R			
1,000pf	102	G	G	G	G		I	I	I	I	I			X	X	X	X	X	N	N	R	R			
1,200pf	122						G	G	G	G				X	X	X	X	X	N	N					
1,500pf	152						G	G	G	G				X	X	X	X	X	N	N					
1,800pf	182						G	G	G	G				X	X	X	X	X	N	N					
2,200pf	222						G	G	G	G				X	X	X	X	X	N	N					
2,700pf	272						G	G	G	G				N	N	N	N	N	N						
3,300pf	332						G	G	G	G				N	N	N	N	N							
3,900pf	392													N	N	N	N	N							
4,700pf	472													N	N	N	N	N							
5,600pf	562													N	N	N	N	N							
6,800pf	682													N	N	N	N	N							
8,200pf	822													N	N	N	N	N							
0.01µF	103													N	N	N	N								
0.012µF	123																								

* ARC PROTECTION COATING

CODE	H	K	Q	R	G	I	N
THICKNESS	0.60 ± 0.10 mm	0.8 ± 0.15/-0.10 mm	1.25 ± 0.10 mm	1.25 ± 0.20 mm	0.50 ± 0.20 mm	0.80 ± 0.07 mm	0.80 ± 0.10 mm



CAPACITANCE RANGE

DIELECTRIC		COG																								
SIZE		1206												1210												
RATED VOLTAGE		10	16	25	50	100	200	250	500	630	1000	1500	2000	10	16	25	50	100	200	250	500	630	1000	1500	2000	3000
1.0pf	1R0				J																					
1.2pf	1R2	J	J	J	J	J			J																	
1.5pf	1R5	J	J	J	J	J	J	J	J	J	J	J	J													
1.8pf	1R8	J	J	J	J	J	J	J	J	J	J	J	J													
2.2pf	2R2	J	J	J	J	J	J	J	J	J	J	J	J													
2.7pf	2R7	J	J	J	J	J	J	J	J	J	J	J	J													
3.3pF	3R3	J	J	J	J	J	J	J	J	J	J	J	J													
3.9pf	3R9	J	J	J	J	J	J	J	J	J	J	J	J													
4.7pf	4R7	J	J	J	J	J	J	J	J	J	J	J	J													
5.0 pF	5R0	J	J	J	J	J	J	J	J	J	J	J	J													
5.6pF	5R6	J	J	J	J	J	J	J	J	J	J	J	J													
6.8pf	6R8	J	J	J	J	J	J	J	J	J	J	J	J													
8.2pf	8R2	J	J	J	J	J	J	J	J	J	J	J	J													
10pf	100	J	J	J	J	J	J	J	J	J	J	J	J	O	O	O	O	O	O	O	O	O	O	O	O	Z
12pF	120	J	J	J	J	J	J	J	J	J	J	J	J	O	O	O	O	O	O	O	O	O	O	O	O	Z
15pF	150	J	J	J	J	J	J	J	J	J	J	J	J	O	O	O	O	O	O	O	O	O	O	O	O	Z
18pF	180	J	J	J	J	J	J	J	J	J	J	J	J	O	O	O	O	O	O	O	O	O	O	O	O	Z
22pF	220	J	J	J	J	J	J	J	J	J	J	J	J	O	O	O	O	O	O	O	O	O	O	O	O	Z
27pF	270	J	J	J	J	J	J	J	J	J	J	J	J	O	O	O	O	O	O	O	O	O	O	O	O	Z
33pF	330	J	J	J	J	J	J	J	J	J	J	J	J	O	O	O	O	O	O	O	O	O	O	O	O	Z
39pF	390	J	J	J	J	J	J	J	J	J	J	J	J	O	O	O	O	O	O	O	O	O	O	O	O	Z
47pF	470	J	J	J	J	J	J	J	J	J	J	J	J	O	O	O	O	O	O	O	O	O	O	O	O	Z
56pF	560	J	J	J	J	J	J	J	J	J	J	J	J	O	Q	Q	O	O	O	O	O	O	O	O	O	Z
68pF	680	J	J	J	J	J	J	J	J	J	J	J	J	O	Q	Q	O	O	O	O	O	O	O	O	O	Z
82pF	820	J	J	J	J	J	J	J	J	J	J	J	J	Q	Q	Q	O	O	O	O	O	O	O	O	O	Z
100pF	101	J	J	J	J	J	J	J	J	J	J	J	J	Q	Q	Q	O	O	O	O	O	O	O	O	O	Z
120pF	121	J	J	J	J	J	J	J	J	J	J	J	J	Q	U	U	O	O	O	O	O	O	O	O	O	Z
150pF	151	J	J	J	J	J	J	J	J	J	J	J	J	Q	U	U	O	O	O	O	O	O	O	O	O	Z
180pF	181	J	J	J	J	J	J	J	J	J	J	J	J	U	U	U	O	O	O	O	O	O	O	O	O	Z
220pF	221	J	J	J	J	J	J	J	J	J	J	J	J	U	U	U	O	O	O	O	O	O	O	O	O	Z
270pF	271	J	J	J	J	J	J	J	J	J	J	J	J	U	V	V	O	O	O	O	O	O	O	O	O	AA
330pF	331	J	J	J	J	J	J	J	J	J	J	J	J	U	V	V	O	O	O	O	O	O	O	O	O	AA
390pF	391	J	J	J	J	J	J	J	J	J	J	J	J	U	V	V	O	O	O	O	O	O	O	O	O	AA
470pF	471	J	J	J	J	J	J	J	J	J	J	J	J	U	U	U	O	O	O	O	O	O	O	O	O	AA
560pF	561	J	J	J	J	J	J	J	J	J	J	J	J	U			O	O	O	O	O	O	O	O	O	AA
680pF	681	J	J	J	J	J	J	J	J	J	J	J	J	U			O	O	O	O	O	O	O	O	O	AA
820pF	821	J	J	J	J	J	J	J	J	J	J	J	J	U			O	O	O	O	O	O	O	O	O	AA
1000pF	102	J	J	J	J	J	J	J	J	J	J	J	J	U			O	O	O	O	O	O	O	O	O	AA
1200pF	122	J	J	J	J	J	J	J	J	J	J	J	J	U			O	O	O	O	O	O	O	O	O	AA
1500pF	152	J	J	J	J	J	J	J	J	J	J	J	J	U			O	O	O	O	O	O	O	O	O	AA
1800pF	182	J	J	J	J	J	J	J	J	J	J	J	J	U			O	O	O	O	O	O	O	O	O	AA
2200pF	222	J	J	J	J	J	J	J	J	J	J	J	J	U			O	O	O	O	O	O	O	O	O	AA
2700pF	272	J	J	J	J	J	J	J	J	J	J	J	J	U			O	O	O	O	O	O	O	O	O	AA
3300pF	332	J	J	J	J	J	J	J	J	J	J	J	J	U			O	O	O	O	O	O	O	O	O	AA
3900pF	392	J	J	J	J	J	J	J	J	J	J	J	J	U			O	O	O	O	O	O	O	O	O	AA
4700pF	472	J	J	J	J	J	J	J	J	J	J	J	J	U			O	O	O	O	O	O	O	O	O	AA
5600pF	562	J	J	J	J	J	J	J	J	J	J	J	J	U			O	O	O	O	O	O	O	O	O	AA
6800pF	682	O	O	O	O	O	U	U	U	U	U	U	U	Q/U			O	O	O	O	O	O	O	O	O	AA
8200pF	822	Q	Q	Q	Q	Q	U	U	U	U	U	U	U	U			O	O	O	O	O	O	O	O	O	AA
0.010µF	103	Q	Q	Q	Q	Q	U	U	U	U	U	U	U	U			O	O	O	O	O	O	O	O	O	AA
0.012µF	123	V	V	V	V	V											Q	Q	Q	Q	U	Z	Z	Z	Z	AA
0.015µF	153	V	V	V	V	V											Q	Q	Q	Q	Z	Z	Z	Z	Z	AA
0.018µF	183	V	V	V	V	V											Z	Z	Z	Z	Z	Z	Z	Z	Z	AA
0.022µF	223	V	V	V	V	V											Z	Z	Z	Z	Z	Z	Z	Z	Z	AA
0.027µF	273	V	V	V	V												Z/AA	Z/AA	Z/AA	Z/AA	Z	Z	Z	AA	AA	
0.033µF	333	V	V	V	V												Z/AA	Z/AA	Z/AA	Z/AA	Z		Z	AA	AA	
0.039µF	393	V	V	V	V												Z/AA	Z/AA	Z/AA	Z/AA	Z		Z			
0.047µF	473				K												Z	Z	Z	Z	Z	Z	Z			
0.056µF	563				K																					
0.068µF	683																									

* ARC PROTECTION COATING

CODE	J	K	O	Q	U	V	Z	AA
THICKNESS	0.80 ± 0.10	0.80 + 0.15/-0.10	0.95 ± 0.10	1.25 ± 0.10	1.60 ± 0.20	1.60 + 0.30/-0.10	2.00 ± 0.20	2.50 ± 0.30





CAPACITANCE RANGE

DIELECTRIC			COG																						
SIZE			1825										2220												
RATED VOLTAGE			25	50	100	200	250	500	630	1000	1500	2000	3000	25	50	100	200	250	500	630	1000	1500	2000	3000	4000
CAPACITANCE RANGE	10pF	100	Z	Z	Z	Z	Z	Z	Z	Z	Z	Z	Z	Z	Z	Z	Z	Z	Z	Z	Z	Z	Z	Z	
	12pF	120	Z	Z	Z	Z	Z	Z	Z	Z	Z	Z	Z	Z	Z	Z	Z	Z	Z	Z	Z	Z	Z	Z	
	15pF	150	Z	Z	Z	Z	Z	Z	Z	Z	Z	Z	Z	Z	Z	Z	Z	Z	Z	Z	Z	Z	Z	Z	
	18pF	180	Z	Z	Z	Z	Z	Z	Z	Z	Z	Z	Z	Z	Z	Z	Z	Z	Z	Z	Z	Z	Z	Z	
	22pF	220	Z	Z	Z	Z	Z	Z	Z	Z	Z	Z	Z	Z	Z	Z	Z	Z	Z	Z	Z	Z	Z	Z	
	27pF	270	Z	Z	Z	Z	Z	Z	Z	Z	Z	Z	Z	Z	Z	Z	Z	Z	Z	Z	Z	Z	Z	Z	
	33pF	330	Z	Z	Z	Z	Z	Z	Z	Z	Z	Z	Z	Z	Z	Z	Z	Z	Z	Z	Z	Z	Z	Z	
	39pF	390	Z	Z	Z	Z	Z	Z	Z	Z	Z	Z	Z	Z	Z	Z	Z	Z	Z	Z	Z	Z	Z	Z	
	47pF	470	Z	Z	Z	Z	Z	Z	Z	Z	Z	Z	Z	Z	Z	Z	Z	Z	Z	Z	Z	Z	Z	Z	
	56pF	560	Z	Z	Z	Z	Z	Z	Z	Z	Z	Z	Z	Z	Z	Z	Z	Z	Z	Z	Z	Z	Z	Z	
	68pF	680	Z	Z	Z	Z	Z	Z	Z	Z	Z	Z	Z	Z	Z	Z	Z	Z	Z	Z	Z	Z	Z	Z	
	82pF	820	Z	Z	Z	Z	Z	Z	Z	Z	Z	Z	Z	Z	Z	Z	Z	Z	Z	Z	Z	Z	Z	Z	
	100pF	101	Z	Z	Z	Z	Z	Z	Z	Z	Z	Z	Z	Z	Z	Z	Z	Z	Z	Z	Z	Z	Z	Z	
	120pF	121	Z	Z	Z	Z	Z	Z	Z	Z	Z	Z	Z	Z	Z	Z	Z	Z	Z	Z	Z	Z	Z	Z	
	150pF	151	Z	Z	Z	Z	Z	Z	Z	Z	Z	Z	Z	Z	Z	Z	Z	Z	Z	Z	Z	Z	Z	Z	
	180pF	181	Z	Z	Z	Z	Z	Z	Z	Z	Z	Z	Z	Z	Z	Z	Z	Z	Z	Z	Z	Z	Z	Z	
	220pF	221	Z	Z	Z	Z	Z	Z	Z	Z	Z	Z	Z	Z	Z	Z	Z	Z	Z	Z	Z	Z	Z	Z	
	270pF	271	Z	Z	Z	Z	Z	Z	Z	Z	Z	Z	Z	Z	Z	Z	Z	Z	Z	Z	Z	Z	Z	AA	
	330pF	331	Z	Z	Z	Z	Z	Z	Z	Z	Z	Z	Z	Z	Z	Z	Z	Z	Z	Z	Z	Z	Z	AA	
	390pF	391	Z	Z	Z	Z	Z	Z	Z	Z	Z	Z	Z	Z	Z	Z	Z	Z	Z	Z	Z	Z	Z	Z	
	470pF	471	Z	Z	Z	Z	Z	Z	Z	Z	Z	Z	Z	Z	Z	Z	Z	Z	Z	Z	Z	Z	Z	Z	
	560pF	561	Z	Z	Z	Z	Z	Z	Z	Z	Z	Z	Z	Z	Z	Z	Z	Z	Z	Z	Z	Z	Z	Z	
	680pF	681	Z	Z	Z	Z	Z	Z	Z	Z	Z	Z	Z	Z	Z	Z	Z	Z	Z	Z	Z	Z	Z	Z	
	820pF	821	Z	Z	Z	Z	Z	Z	Z	Z	Z	Z	Z	Z	Z	Z	Z	Z	Z	Z	Z	Z	Z	Z	
	1000pF	102	Z	Z	Z	Z	Z	Z	Z	Z	Z	Z	Z	Z	Z	Z	Z	Z	Z	Z	Z	Z	Z	Z	
	1200pF	122	Z	Z	Z	Z	Z	Z	Z	Z	Z	Z	Z	Z	Z	Z	Z	Z	Z	Z	Z	Z	Z	Z	
	1500pF	152	Z	Z	Z	Z	Z	Z	Z	Z	Z	Z	Z	Z	Z	Z	Z	Z	Z	Z	Z	Z	Z	Z	
	1800pF	182	Z	Z	Z	Z	Z	Z	Z	Z	Z	Z	Z	Z	Z	Z	Z	Z	Z	Z	Z	Z	Z	Z	
	2200pF	222	Z	Z	Z	Z	Z	Z	Z	Z	Z	Z	Z	Z	Z	Z	Z	Z	Z	Z	Z	Z	Z	Z	
	2700pF	272	Z	Z	Z	Z	Z	Z	Z	Z	Z	Z	Z	Z	Z	Z	Z	Z	Z	Z	Z	Z	Z	Z	
	3300pF	332	Z	Z	Z	Z	Z	Z	Z	Z	Z	Z	Z	Z	Z	Z	Z	Z	Z	Z	Z	Z	Z	Z	
	3900pF	392	Z	Z	Z	Z	Z	Z	Z	Z	Z	Z	Z	Z	Z	Z	Z	Z	Z	Z	Z	Z	Z	Z	
	4700pF	472	Z	Z	Z	Z	Z	Z	Z	Z	Z	Z	Z	Z	Z	Z	Z	Z	Z	Z	Z	Z	Z	Z	
	5600pF	562	Z	Z	Z	Z	Z	Z	Z	Z	Z	Z	Z	Z	Z	Z	Z	Z	Z	Z	Z	Z	Z	Z	
6800pF	682	Z	Z	Z	Z	Z	Z	Z	Z	Z	Z	Z	Z	Z	Z	Z	Z	Z	Z	Z	Z	Z	Z		
8200pF	822	Z	Z	Z	Z	Z	Z	Z	Z	AA												AA			
0.01µF	103	Z	Z	Z	Z	Z	Z	Z	AA													AA			
0.012µF	123	Z	Z	Z	Z	Z	Z	Z																	
0.015µF	153	Z	Z	Z	Z	Z	Z	Z																	
0.018µF	183	Z	Z	Z	Z	Z	Z	Z																	
0.022µF	223	Z	Z	Z	Z	Z	Z	Z																	
0.027µF	273	Z	Z	Z	Z	Z	Z	Z																	
0.033µF	333	Z	Z	Z	Z	Z	Z	Z																	
0.039µF	393	Z	Z	U	Z	Z	AA	AA														U/Z			
0.047µF	473	Z	Z	Z	Z	Z																U/Z			
0.056µF	563	Z	Z	Z	AA	AA																Z			
0.068µF	683	Z	Z	Z	AA	AA																Z			
0.082µF	823	Z	Z	AA																		Z			
0.1µF	104	AA	AA	AA																		AA			
0.12µF	124																								
0.15µF	154																								
0.18µF	184																								
0.22µF	224																								
0.27µF	274																								
0.33µF	334																								

* ARC PROTECTION COATING

CODE	U	Z	AA
THICKNESS	1.60 ± 0.20	2.00 ± 0.20	2.50 ± 0.30





CAPACITANCE RANGE

DIELECTRIC		COG											
SIZE		2225											
RATED VOLTAGE		25	50	100	200	250	500	630	1000	1500	2000	3000	4000
10pF	100	Z	Z	F	F	F	F	F	F	F	F	F	
12pF	120	Z	Z	Z	Z	Z	Z	Z	Z	Z	Z	Z	
15pF	150	Z	Z	Z	Z	Z	Z	Z	Z	Z	Z	Z	
18pF	180	Z	Z	Z	Z	Z	Z	Z	Z	Z	Z	Z	
22pF	220	Z	Z	Z	Z	Z	Z	Z	Z	Z	Z	Z	
27pF	270	Z	Z	Z	Z	Z	Z	Z	Z	Z	Z	Z	Z
33pF	330	Z	Z	Z	Z	Z	Z	Z	Z	Z	Z	Z	Z
39pF	390	Z	Z	Z	Z	Z	Z	Z	Z	Z	Z	Z	Z
47pF	470	Z	Z	Z	Z	Z	Z	Z	Z	Z	Z	Z	Z
56pF	560	Z	Z	Z	Z	Z	Z	Z	Z	Z	Z	Z	Z
68pF	680	Z	Z	Z	Z	Z	Z	Z	Z	Z	Z	Z	Z
82pF	820	Z	Z	Z	Z	Z	Z	Z	Z	Z	Z	Z	Z
100pF	101	Z	Z	Z	Z	Z	Z	Z	Z	Z	Z	Z	Z
120pF	121	Z	Z	Z	Z	Z	Z	Z	Z	Z	Z	Z	
150pF	151	Z	Z	Z	Z	Z	Z	Z	Z	Z	Z	Z	
180pF	181	Z	Z	Z	Z	Z	Z	Z	Z	Z	Z	Z	
220pF	221	Z	Z	Z	Z	Z	Z	Z	Z	Z	Z	Z	
270pF	271	Z	Z	Z	Z	Z	Z	Z	Z	Z	Z	Z	
330pF	331	Z	Z	Z	Z	Z	Z	Z	Z	Z	Z	Z	
390pF	391	Z	Z	Z	Z	Z	Z	Z	Z	Z	Z	Z	
470pF	471	Z	Z	Z	Z	Z	Z	Z	Z	Z	Z	Z	
560pF	561	Z	Z	Z	Z	Z	Z	Z	Z	Z	Z	Z	
680pF	681	Z	Z	Z	Z	Z	Z	Z	Z	Z	Z	Z	
820pF	821	Z	Z	Z	Z	Z	Z	Z	Z	Z	Z	Z	
1000pF	102	Z	Z	Z	Z	Z	Z	Z	Z	Z	Z	Z	
1200pF	122	Z	Z	Z	Z	Z	Z	Z	Z	Z	Z	Z	
1500pF	152	Z	Z	Z	Z	Z	Z	Z	Z	Z	Z	Z	
1800pF	182	Z	Z	Z	Z	Z	Z	Z	Z	Z	Z	Z	
2200pF	222	Z	Z	Z	Z	Z	Z	Z	Z	Z	Z	Z	
2700pF	272	Z	Z	Z	Z	Z	Z	Z	Z	Z	Z	AA	
3300pF	332	Z	Z	Z	Z	Z	Z	Z	Z	Z	Z	AA	
3900pF	392	Z	Z	Z	Z	Z	Z	Z	Z	Z	Z	Z	
4700pF	472	Z	Z	Z	Z	Z	Z	Z	Z	Z	Z	Z	
5600pF	562	Z	Z	Z	Z	Z	Z	Z	Z	Z	Z	Z	
6800pF	682	Z	Z	Z	Z	Z	Z	Z	Z	Z	Z	Z	
8200pF	822	Z	Z	Z	Z	Z	Z	Z	AA	AA	AA		
0.01µF	103	Z	Z	Z	Z	Z	Z	Z	AA	AA	AA		
0.012µF	123	Z	Z	Z	Z	Z	Z	Z					
0.015µF	153	Z	Z	Z	Z	Z	Z	Z					
0.018µF	183	Z	Z	Z	Z	Z	Z	Z					
0.022µF	223	Z	Z	Z	Z	Z	Z	Z					
0.027µF	273	Z	Z	Z	Z	Z	Z	Z					
0.033µF	333	Z	Z	Z	Z	Z	Z	Z					
0.039µF	393	Z	Z	Z	Z	Z	Z	Z					
0.047µF	473	Z	Z	Z	Z	Z	Z	Z					
0.056µF	563	Z	Z	Z	AA	AA	AA	AA					
0.068µF	683	Z	Z	Z	AA	AA	AA	AA					
0.082µF	823	Z	Z	Z	AA	AA	AA						
0.1µF	104	Z	Z	AA	AA	AA							
0.12µF	124												
0.15µF	154												
0.18µF	184												
0.22µF	224												
0.27µF	274												
0.33µF	334												

* ARC PROTECTION COATING

CODE	Z	AA
THICKNESS	2.00 ± 0.20	2.50 ± 0.30



CAPACITANCE RANGE

DIELECTRIC		X7R																										
SIZE		0402						0603						0805														
RATED VOLTAGE		6.3	10	16	25	35	50	100	6.3	10	16	25	35	50	100	200	250	6.3	10	16	25	50	100	200	250	500	630	1000
100pf	101		G	G	G		G	G		I	I	I	I	I	I	K	K		Q	Q	Q	Q	Q	Q	Q	N	N	N
120pf	121		G	G	G		G	G		I	I	I	I	I	I	K	K		Q	Q	Q	Q	Q	Q	Q	N	N	N
150pf	151		G	G	G		G	G		I	I	I	I	I	I	K	K		Q	Q	Q	Q	Q	Q	Q	N	N	N
180pf	181		G	G	G		G	G		I	I	I	I	I	I	K	K		Q	Q	Q	Q	Q	Q	Q	N	N	N
220pf	221		G	G	G		G	G		I	I	I	I	I	I	K	K		Q	Q	Q	Q	Q	Q	Q	N	N	N
270pf	271		G	G	G		G	G		I	I	I	I	I	I	K	K		Q	Q	Q	Q	Q	Q	Q	N	N	N
330pf	331		G	G	G		G	G		I	I	I	I	I	I	K	K		Q	Q	Q	Q	Q	Q	Q	N	N	N
390	391		G	G	G		G	G		I	I	I	I	I	I	K	K		Q	Q	Q	Q	Q	Q	Q	N	N	N
470pf	471		G	G	G		G	G		I	I	I	I	I	I	K	K		Q	Q	Q	Q	Q	Q	Q	N	N	N
560pf	561		G	G	G		G	G		I	I	I	I	I	I	K	K		Q	Q	Q	Q	Q	Q	Q	N	N	N
680pf	681		G	G	G		G	G		I	I	I	I	I	I	K	K		Q	Q	Q	Q	Q	Q	Q	N	N	N
820pf	821		G	G	G		G	G		I	I	I	I	I	I	K	K		Q	Q	Q	Q	Q	Q	Q	N	N	N
1,000pf	102		G	G	G		G	G		I	I	I	I	I	I	K	K		Q	Q	Q	Q	Q	Q	Q	N	N	N
1,200pf	122		G	G	G		G	G		I	I	I	I	I	I	K	K		Q	Q	Q	Q	Q	Q	Q	N	N	N
1,500pf	152		G	G	G		G	G		I	I	I	I	I	I	K	K		Q	Q	Q	Q	Q	Q	Q	N	N	Q
1,800pf	182		G	G	G		G	G		I	I	I	I	I	I	K	K		Q	Q	Q	Q	Q	Q	Q	N	N	Q
2,200pf	222		G	G	G		G	G		I	I	I	I	I	I	K	K		Q	Q	Q	Q	Q	Q	Q	N	N	Q
2,700pf	272		G	G	G		G	G		I	I	I	I	I	I	K	K		Q	Q	Q	Q	Q	Q	Q	N	N	
3,300pf	332		G	G	G		G	G		I	I	I	I	I	I	K	K		Q	Q	Q	Q	Q	Q	Q	N	N	
3,900pf	392		G	G	G		G	G		I	I	I	I	I	I	K	K		Q	Q	Q	Q	Q	Q	Q	N	N	
4,700pf	472		G	G	G		G	G		I	I	I	I	I	I	K	K		Q	Q	Q	Q	Q	Q	Q	N	N	
5,600pf	562		G	G	G		G			I	I	I	I	I	I	K	K		Q	Q	Q	Q	Q	Q	Q	Q	Q	
6,800pf	682		G	G	G		G			I	I	I	I	I	I	K	K		Q	Q	Q	Q	Q	Q	Q	Q	Q	
8,200pf	822		G	G	G		G			I	I	I	I	I	I	K	K		Q	Q	Q	Q	Q	Q	Q	Q	Q	
0.01µF	103		G	G	G		G			I	I	I	I	I	I	K	K		Q	Q	Q	Q	Q	Q	Q	Q	Q	
0.012µF	123		G	G	G					I	I	I	I	I	I	K			Q	Q	Q	Q	Q	Q	Q	Q	Q	
0.015µF	153		G	G	G					I	I	I	I	I	I	K			Q	Q	Q	Q	Q	Q	Q	Q	Q	
0.018µF	183		G	G	G					I	I	I	I	I	I	K			Q	Q	Q	Q	Q	Q	Q	Q	Q	
0.022µF	223		G	G	G					I	I	I	I	I	I	K			Q	Q	Q	Q	Q	Q	Q	Q	Q	
0.027µF	273		G	G	G					I	I	I	I	I	I	K			Q	Q	Q	Q	Q	Q	Q	Q	Q	
0.033µF	333		G	G	G					I	I	I	I	I	I	K	K		Q	Q	Q	Q	Q	Q	Q	Q	Q	
0.039µF	393		G	G	G					I	I	I	I	I	I	K	K		Q	Q	Q	Q	Q	Q	Q	Q	Q	
0.047µF	473		G	G	G					I	I	I	I	I	I	K	K		Q	Q	Q	Q	Q	Q	Q	Q	Q	
0.056µF	563		G	G						I	I	I	I	I	I	K	K		Q	Q	Q	Q	Q	Q	Q	Q	Q	
0.068µF	683		G	G						I	I	I	I	I	I	K	K		Q	Q	Q	Q	Q	Q	Q	Q	Q	
0.082µF	823		G	G						I	I	I	I	I	I	K	K		Q	Q	Q	Q	Q	Q	Q	Q	Q	
0.1µF	104	G	G	G						I	I	I	I	I	I	K	K		Q	Q	Q	Q	Q	Q	Q	Q	Q	
0.12µF	124									I	I	I	I	I	I	K			Q	Q	Q	Q	Q	Q	Q	Q	Q	
0.15µF	154									I	I	I	I	I	I	K			Q	Q	Q	Q	Q	Q	Q	Q	Q	
0.18µF	184									I	I	I	I	I	I	K			Q	Q	Q	Q	Q	Q	Q	Q	Q	
0.22µF	224									I	I	I	I	I	I	K	K		Q	Q	Q	Q	Q	Q	Q	Q	Q	
0.27µF	274								K	K	K	K							R	R	R	R						
0.33µF	334									K	K	K							R	R	R	R						
0.39µF	394									K	K	K							R	R	R	R						
0.47µF	474									K	K	K							R	R	R	R						
0.56µF	564										K	K							R	R	R	R						
0.68µF	684										K	K							R	R	R							
0.82µF	824										K	K							R	R	R							
1µF	105										K	K	K	K	N				R	R	R	R						
1.2µF	125										K	K	K	K	K													
1.5µF	155										K	K	K	K	K					R	R	R						
2.2µF	225										K	K	K	K	K					R	R	R	R					
4.7µF	475																			R	R	R	R					
10µF	106									L#	L#								S	S								

* ARC PROTECTION COATING
- L: 1.6 ± 0.3 W: 0.8 ± 0.3

CODE	G	I	N	K	L	Q	R	S
THICKNESS	0.50 ± 0.20	0.80 ± 0.07	0.80 ± 0.10	0.8 ± 0.15/-0.10	0.8 ± 0.25	1.25 ± 0.10	1.25 ± 0.20	1.25 ± 0.30



CAPACITANCE RANGE

CAPACITANCE RANGE	DIELECTRIC		X7R																											
	SIZE		1206										1210																	
	RATED VOLTAGE		6.3	10	16	25	50	100	200	250	500	630	1000	1500	2000	6.3	10	16	25	50	100	200	250	500	630	1000	1500	2000		
100pf	101							Q	Q	Q	Q	Q	Q	Q																
120pf	121							Q	Q	Q	Q	Q	Q	Q																
150pf	151		Q	Q	Q	Q	Q	Q	Q	Q	Q	Q	Q	Q																
180pf	181		Q	Q	Q	Q	Q	Q	Q	Q	Q	Q	Q	Q																
220pf	221		Q	Q	Q	Q	Q	Q	Q	Q	Q	Q	Q	Q					O	O	O	O	O	O	O	O	O	O	M	
270pf	271		Q	Q	Q	Q	Q	Q	Q	Q	Q	Q	Q	Q					O	O	O	O	O	O	O	O	O	O	M	
330pf	331		Q	Q	Q	Q	Q	Q	Q	Q	Q	Q	Q	Q					O	O	O	O	O	O	O	O	O	O	M	
390	391		Q	Q	Q	Q	Q	Q	Q	Q	Q	Q	Q	Q					O	O	O	O	O	O	O	O	O	O	M	
470pf	471		Q	Q	Q	Q	Q	Q	Q	Q	Q	Q	Q	Q					O	O	O	O	O	O	O	O	O	O	M	
560pf	561		Q	Q	Q	Q	Q	Q	Q	Q	Q	Q	Q	Q					O	O	O	O	O	O	O	O	O	O	M	
680pf	681		Q	Q	Q	Q	Q	Q	Q	Q	Q	Q	Q	Q					O	O	O	O	O	O	O	O	O	O	M	
820pf	821		Q	Q	Q	Q	Q	Q	Q	Q	Q	Q	Q	Q					O	O	O	O	O	O	O	O	O	O	M	
1,000pf	102		Q	Q	Q	Q	Q	Q	Q	Q	Q	Q	Q	Q					O	O	O	O	O	O	O	O	O	Q	Q	
1,200pf	122		Q	Q	Q	Q	Q	Q	Q	Q	Q	Q	Q	U	U					O	O	O	O	O	O	O	O	U	U	
1,500pf	152		Q	Q	Q	Q	Q	Q	Q	Q	Q	Q	Q	U	U					O	O	O	O	O	O	O	O	U	U	
1,800pf	182		Q	Q	Q	Q	Q	Q	Q	Q	Q	Q	Q	U	U					O	O	O	O	O	O	O	O	U	U	
2,200pf	222		Q	Q	Q	Q	Q	Q	Q	Q	Q	Q	Q	U	U					O	O	O	O	O	O	O	O	Z	Z	
2,700pf	272		Q	Q	Q	Q	Q	Q	Q	Q	Q	Q	Q	U	U					O	O	O	O	O	O	O	O	Z	AA	
3,300pf	332		Q	Q	Q	Q	Q	Q	Q	Q	Q	Q	Q	U	U					O	O	O	O	O	O	O	O	Z	AA	
3,900pf	392		Q	Q	Q	Q	Q	Q	Q	Q	Q	Q	Q	U						O	O	O	O	O	O	O	O	AA	AA	
4,700pf	472		Q	Q	Q	Q	Q	Q	Q	Q	Q	Q	Q	U						O	O	O	O	O	O	O	O	Z/AA	Z/AA	
5,600pf	562		Q	Q	Q	Q	Q	Q	Q	Q	Q	Q	Q	U						O	O	O	O	O	O	O	O	AA	AA*	
6,800pf	682		Q	Q	Q	Q	Q	Q	Q	Q	Q	Q	Q	U						O	O	O	O	O	O	O	O	AA	AA*	
8,200pf	822		Q	Q	Q	Q	Q	Q	Q	Q	Q	Q	Q	U						O	O	O	O	O	O	O	O	AA	AA*	
0.01µF	103		Q	Q	Q	Q	Q	Q	Q	Q	Q	Q	Q	U						O	O	O	O	O	O	O	Q	AA	AA*	
0.012µF	123		Q	Q	Q	Q	Q	Q	Q	Q	Q	Q	Q	U						O	O	O	O	O	O	O	Q	AA		
0.015µF	153		Q	Q	Q	Q	Q	Q	Q	Q	Q	Q	Q	U						O	O	O	O	O	O	O	U	AA		
0.018µF	183		Q	Q	Q	Q	Q	Q	Q	Q	Q	Q	Q	U						O	O	O	O	O	O	Q	Q	U	AA	
0.022µF	223		Q	Q	Q	Q	Q	Q	Q	Q	Q	Q	Q	U	U					O	O	O	O	O	O	O	Q	U	AA	
0.027µF	273		Q	Q	Q	Q	Q	Q	Q	Q	Q	Q	Q	U	U					O	O	O	O	O	O	Q	Q	U	AA	
0.033µF	333		Q	Q	Q	Q	Q	Q	U	U	U	U	U							O	O	O	O	O	O	U	U	U	AA	
0.039µF	393		Q	Q	Q	Q	Q	Q	U	U	U	U	U							O	O	O	O	O	O	U	U	Z		
0.047µF	473		Q	Q	Q	Q	Q	Q	U	U	U	U	U							O	O	O	O	O	Q	Q	U	U	AA	
0.056µF	563		Q	Q	Q	Q	Q	Q	U	U	U	U	U							O	O	O	O	O	Q	Q	U	U		
0.068µF	683		Q	Q	Q	Q	Q	Q	U	U	U	U	U							O	O	O	O	O	U	U	Z	Z		
0.082µF	823		Q	Q	Q	Q	Q	Q	U	U	U	U	U							O	O	O	O	O	U	U	Z	Z		
0.1µF	104		Q	Q	Q	Q	Q	Q	U	U										O	O	O	O	O	Y	Y	Z	Z		
0.12µF	124		Q	Q	Q	Q	Q	Q												O	O	O	O	O	U	U	AA	AA		
0.15µF	154		O	O	O	O	U													O	O	O	O	Q	U	U	AA	AA		
0.18µF	184		O	O	O	O	U													O	O	O	O	Q	U	U				
0.22µF	224		O	O	O	O	U	U												O	O	O	O	Q	Q/U	Q/U				
0.27µF	274		O	O	O	Q	U													O	O	O	O	U	Z	Z				
0.33µF	334		O	O	O	Q	U													O	O	O	O	Q	U	Z	Z			
0.39µF	394		O	O	P	V	U													O	O	O	O	Q	AA	AA	AA			
0.47µF	474		P	P	P	V	U													O	O	O	O	Q	AA	AA	AA			
0.56µF	564		P	P	P	V	V													Q	Q	Q	Q	Q	AA	AA	AA			
0.68µF	684		P	P	P	V	V													Q	Q	Q	Q	Q	Z	AA	AA			
0.82µF	824		P	P	P	V	V													Q	Q	Q	Q	Q	Z					
1.0µF	105		P	P	P	V	V													Q	Q	Q	Q	Q	Z					
1.2µF	125				V	V	V																							
1.5µF	155		P	P	P	V	V	V															Z	U	AA	AA				
1.8µF	185				V	V	V																							
2.2µF	225		P	P	P	V	V	U															Z	U	AA	AA				
2.7µF	275				V	V	V																							
3.3µF	335		V	V	V	V	V																Z	U	AA	AA				
3.9µF	395				V	V	V																							
4.7µF	475		V	V	V	V	V																Z	Z	Z	Z	AA	AA		
10µF	106		V	V	V	V	V																Z	Z	Z	AA	AA			
22µF	226		V																				AA	AA	AA					
47µF	476																						AA	AA						

* ARC PROTECTION COATING

CODE	O	P	Q	U	V	Y	Z	AA
THICKNESS	0.95 ± 0.10	1.15 ± 0.15	1.25 ± 0.10	1.60 ± 0.20	1.60 +0.3/-0.10	1.90 ± 0.20	2.00 ± 0.20	2.50 ± 0.30





CAPACITANCE RANGE

CAPACITANCE RANGE	DIELECTRIC		X7R																				
	SIZE		1808							1812													
	RATED VOLTAGE		500	630	1000	1500	2000	3000	4000	10	16	25	50	100	200	250	400	500	630	1000	1500	2000	3000
150pf	151	Q	Q	Q	Q	Q	Q	Z*															
180pf	181	Q	Q	Q	Q	Q	Q	Z*															
220pf	221	Q	Q	Q	Q	Q	Q	Z*															
270pf	271	Q	Q	Q	Q	Q	Q	Z*	Q	Q	Q	Q	Q	Q	Q	Q	Q	Q	Q	Q	Q	Q	Z*
330pf	331	Q	Q	Q	Q	Q	Q	Z*	Q	Q	Q	Q	Q	Q	Q	Q	Q	Q	Q	Q	Q	Q	Z*
390	391	Q	Q	Q	Q	Q	Q	Z*	Q	Q	Q	Q	Q	Q	Q	Q	Q	Q	Q	Q	Q	Q	Z*
470pf	471	Q	Q	Q	Q	Q	Q	Z*	Q	Q	Q	Q	Q	Q	Q	Q	Q	Q	Q	Q	Q	Q	Z*
560pf	561	Q	Q	Q	Q	Q	U	Z*	Q	Q	Q	Q	Q	Q	Q	Q	Q	Q	Q	Q	Q	Q	Z*
680pf	681	Q	Q	Q	Q	Q	U	Z*	Q	Q	Q	Q	Q	Q	Q	Q	Q	Q	Q	Q	Q	Q	Z*
820pf	821	Q	Q	Q	Q	Q	U	Z*	Q	Q	Q	Q	Q	Q	Q	Q	Q	Q	Q	Q	Q	Q	Z*
1,000pf	102	Q	Q	Q	Q	Q	Z	Z*	Q	Q	Q	Q	Q	Q	Q	Q	Q	Q	Q	Q	Q	U	Z*
1,200pf	122	Q	Q	Q	Q	Q	Z		Q	Q	Q	Q	Q	Q	Q	Q	Q	Q	Q	Q	Q	Z	G*
1,500pf	152	Q	Q	Q	Q	Q	Z		Q	Q	Q	Q	Q	Q	Q	Q	Q	Q	Q	Q	Q	Z	G*
1,800pf	182	Q	Q	Q	Q	Q	Z		Q	Q	Q	Q	Q	Q	Q	Q	Q	Q	Q	Q	Q	AA	G*
2,200pf	222	Q	Q	Q	U	U	Z		Q	Q	Q	Q	Q	Q	Q	Q	Q	Q	Q	Q	Q	Q	G*
2,700pf	272	Q	Q	Q	Z	Z	Z		Q	Q	Q	Q	Q	Q	Q	Q	Q	Q	Q	Q	Q	Q	G*
3,300pf	332	Q	Q	Q	Z	Z	Z		Q	Q	Q	Q	Q	Q	Q	Q	Q	Q	Q	U	U	G*	
3,900pf	392	Q	Q	Q	Z	Z	Z*		Q	Q	Q	Q	Q	Q	Q	Q	Q	Q	Q	Z	Z	G*	
4,700pf	472	Q	Q	Q	Z	Z	Z*		Q	Q	Q	Q	Q	Q	Q	Q	Q	Q	Q	Z	Z	G*	
5,600pf	562	Q	Q	Q	Z	Z	Z*		Q	Q	Q	Q	Q	Q	Q	Q	Q	Q	Q	AA	AA		
6,800pf	682	Q	Q	Q	Z	Z	Z*		Q	Q	Q	Q	Q	Q	Q	Q	Q	Q	Q	AA	AA		
8,200pf	822	Q	Q	Q	Z*	Z*	Z*		Q	Q	Q	Q	Q	Q	Q	Q	Q	Q	Q	AA	AA		
0.01µF	103	Q	Q	Q	Z*	Z*	Z*		Q	Q	Q	Q	Q	Q	Q	Q	Q	Q	Q	U/Z/AA	U/Z/AA		
0.012µF	123	U	U	U					Q	Q	Q	Q	Q	Q	Q	Q	Q	Q	Q	U/Z/AA			
0.015µF	153	U	U	U					Q	Q	Q	Q	Q	Q	Q	Q	Q	Q	Q	U/Z/AA			
0.018µF	183	Z	Z	Z					Q	Q	Q	Q	Q	Q	Q	Q	Q	Q	U	U/Z/AA			
0.022µF	223	Z	Z	Z					Q	Q	Q	Q	Q	Q	Q	Q	Q	Q	U	Z/AA			
0.027µF	273	Z	Z	Z					Q	Q	Q	Q	Q	Q	Q	Q	Q	Q	Z				
0.033µF	333	Z	Z	Z					Q	Q	Q	Q	Q	Q	Q	Q	Q	Q	Z				
0.039µF	393	Z	Z	Z					Q	Q	Q	Q	Q	Q	Q	Q	Q	Q	AA				
0.047µF	473	Z	Z	Z					Q	Q	Q	Q	Q	Q	Q	Q	Q	Q	Z/AA				
0.056µF	563	Z	Z	Z					Q	Q	Q	Q	Q	Q	Q	Q	U	U	AA				
0.068µF	683	Z	Z						Q	Q	Q	Q	Q	Q	Q	Q	U	U	AA				
0.082µF	823	Z	Z						Q	Q	Q	Q	Q	Q	Q	U	U	AA					
0.1µF	104								Q	Q	Q	Q	Q	Q	Q	U	U	AA					
0.12µF	124								Q	Q	Q	Q	Q	Q	Q	Z	Z						
0.15µF	154								Q	Q	Q	Q	Q	Q	Q	Z	Z						
0.18µF	184								Q	Q	Q	Q	Q	Q	Q	AA	AA						
0.22µF	224								Q	Q	Q	Q	Q	Q	Q	AA	AA						
0.27µF	274								Q	Q	Q	Q	Q	U	U	U	AA						
0.33µF	334								Q	Q	Q	Q	Q	U	U	U	AA						
0.39µF	394								Q	Q	Q	Q	Q	Z	Z	Z	AA						
0.47µF	474								Q	Q	Q	Q	Q	Z	Z	Z	AA						
0.56µF	564								Q	Q	Q	Q	Q	AA	AA								
0.68µF	684								Q	Q	Q	Q	Q	AA	AA								
0.82µF	824								Q	Q	Q	Q	Q	AA	AA								
1.0µF	105								Q	Q	Q	Q	Q	AA	AA								
1.2µF	125								Q	Q	Q	Q	Q										
1.5µF	155								Q	Q	Q	Q	Q										
1.8µF	185								U	U	U	U	U										
2.2µF	225								U	U	U	U	U										
2.7µF	275								Z	Z	Z	Z	Z										
3.3µF	335								Z	Z	Z	Z	Z										
3.9µF	395								Z	Z	Z	Z	Z										
4.7µF	475								AA	AA	AA	AA	AA										
5.6µF	565								AA	AA	AA	AA											
6.8µF	685								AA	AA	AA	AA											
8.2µF	825								AA	AA	AA	AA											
10µF	106								AA	AA	AA	AA											
12µF	126								AA	AA	AA												
15µF	156								AA	AA	AA												
18µF	186								AA	AA	AA												

* ARC PROTECTION COATING

CODE	Q	U	Z	AA
THICKNESS	1.25 ± 0.10	1.60 ± 0.20	2.00 ± 0.20	2.50 ± 0.30





CAPACITANCE RANGE

DIELECTRIC		X7R												
SIZE		2225												
RATED VOLTAGE		25	50	100	200	250	500	630	1000	1500	2000	3000	4000	5000
220pf	221													
270pf	271												Z*	Z*
330pf	331												Z*	Z*
390pF	391												Z*	Z*
470pf	471												Z*	Z*
560pf	561												Z*	Z*
680pf	681												Z*	Z*
820pf	821												Z*	Z*
1,000pf	102	Z	Z	Z	Z	Z	Z	Z	Z	Z	Z	Z*	Z*	Z*
1,200pf	122	Z	Z	Z	Z	Z	Z	Z	Z	Z	Z	Z*	AA*	Z*
1,500pf	152	Z	Z	Z	Z	Z	Z	Z	Z	Z	Z	Z*	AA*	Z*
1,800pf	182	Z	Z	Z	Z	Z	Z	Z	Z	Z	Z	Z*	AA*	Z*
2,200pf	222	Z	Z	Z	Z	Z	Z	Z	Z	Z	Z	Z*		Z*
2,700pf	272	Z	Z	Z	Z	Z	Z	Z	Z	Z	Z	Z*		Z*
3,300pf	332	Z	Z	Z	Z	Z	Z	Z	Z	Z	Z	Z*		Z*
3,900pf	392	Z	Z	Z	Z	Z	Z	Z	Z	Z	Z	Z*		Z*
4,700pf	472	Z	Z	Z	Z	Z	Z	Z	Z	Z	Z	Z*		Z/AA*
5,600pf	562	Z	Z	Z	Z	Z	Z	Z	Z	Z	Z	AA*		
6,800pf	682	Z	Z	Z	Z	Z	Z	Z	Z	Z	Z	AA*		
8,200pf	822	Z	Z	Z	Z	Z	Z	Z	Z	Z	Z	AA*		
0.01µF	103	Z	Z	Z	Z	Z	Z	Z	Z	Z	Z	AA*		
0.012µF	123	Z	Z	Z	Z	Z	Z	Z	Z	AA	AA	AA*		
0.015µF	153	Z	Z	Z	Z	Z	Z	Z	Z	AA	AA	AA*		
0.018µF	183	Z	Z	Z	Z	Z	Z	Z	Z	AA	AA	BB*		
0.022µF	223	Z	Z	Z	Z	Z	Z	Z	Z	Z/AA	Z/AA			
0.027µF	273	Z	Z	Z	Z	Z	Z	Z	Z	AA	AA			
0.033µF	333	Z	Z	Z	Z	Z	Z	Z	Z	AA	AA			
0.039µF	393	Z	Z	Z	Z	Z	Z	Z	Z	AA	BB			
0.047µF	473	Z	Z	Z	Z	Z	Z	Z	Z	AA	BB			
0.056µF	563	Z	Z	Z	Z	Z	Z	Z	Z	AA	BB			
0.068µF	683	Z	Z	Z	Z	Z	Z	Z	Z	AA				
0.082µF	823	Z	Z	Z	Z	Z	Z	Z	Z	AA				
0.1µF	104	Z	Z	Z	Z	Z	Z	Z	AA	AA	AA			
0.12µF	124	Z	Z	Z	Z	Z	Z	Z	BB					
0.15µF	154	Z	Z	Z	Z	Z	Z	Z	BB					
0.18µF	184	Z	Z	Z	Z	Z	Z	Z	BB					
0.22µF	224	Z	Z	Z	Z	Z	Z	Z	BB					
0.27µF	274	Z	Z	Z	Z	Z	Z	Z	Z/AA/BB					
0.33µF	334	Z	Z	Z	Z	Z	Z	Z	Z/AA/BB					
0.39µF	394	Z	Z	Z	Z	Z	Z	Z						
0.47µF	474	Z	Z	Z	Z	Z	Z	Z						
0.56µF	564	Z	Z	Z	Z	Z	Z	Z						
0.68µF	684	Z	Z	Z	Z	Z								
0.82µF	824	Z	Z	Z	Z	Z								
1µF	105	Z	Z	Z	Z	Z								
1.2µF	125	Z	Z	Z	AA	AA								
1.5µF	155	Z	Z	Z	AA	AA								
1.8µF	185	Z	Z	Z	AA	AA								
2.2µF	225	Z	Z	Z	AA	AA								
2.7µF	275	Z	Z	Z	AA	AA								
3.3µF	335	Z	Z	Z										
3.9µF	395	Z	Z	Z										
4.7µF	475	Z	Z	Z										
5.6µF	565	Z	Z	Z										
6.8µF	685	Z	Z	Z										
8.2µF	825	AA	AA	AA										
10µF	106	AA	AA	AA										
12µF	126	Z/AA												
15µF	156	Z/AA												

* ARC PROTECTION COATING

CODE	Z	AA	BB
THICKNESS	2.00 ± 0.20	2.50 ± 0.30	2.80 ± 0.30





RELIABILITY TEST CONDITIONS AND REQUIREMENTS

NO.	ITEM	TEST CONDITION	REQUIREMENTS																																																																																																																																																				
1.	Visual and Mechanical	---	- No remarkable damage. - Dimensions to conform to individual specification sheet.																																																																																																																																																				
2.	Capacitance	<p>- Class I : Cap. ≤ 1000pF, 1.0±0.2Vrms, 1MHz±10%. Cap. > 1000pF, 1.0±0.2Vrms, 1KHz±10%.</p> <p>- Class II : Cap. ≤ 10μF, 1.0±0.2Vrms, 1KHz±10%**. Cap. > 10μF, 0.5±0.2Vrms, 120Hz±20%.</p> <p>** Test condition: 0.5±0.2Vrms, 1KHz±10%</p> <p>- X7R: 0805 - 106 (6.3V), 0603/475 (6.3V)</p> <p>- X7S: 0805 - 106 (6.3V), 0603/475 (6.3V)</p> <p>-X5R- 0402≥475 (6.3V,16V), 0402≥225(10V), 0603=106 (6,3V)</p> <p>#1 Excluding GMX04X5R475M6R3NT (1.0±0.2Vrms, 1KHz±10%)</p>	<p>- Shall not exceed the limits given in the detailed spec.</p> <p>- Class I :</p> <table border="1"> <thead> <tr> <th>DIELECTRIC</th> <th>RATED VOL.</th> <th>Q/D.F</th> <th>REMARK</th> </tr> </thead> <tbody> <tr> <td>Class 1</td> <td>All</td> <td>Q₂≥1000</td> <td>Cap.≥30pF</td> </tr> <tr> <td></td> <td></td> <td>Q₂≥400+20C</td> <td>Cap. <30pF</td> </tr> </tbody> </table> <p>- Class II:</p> <table border="1"> <thead> <tr> <th>RATED</th> <th>D.F.≤</th> <th colspan="2">EXCEPTION OF D.F.≤</th> </tr> </thead> <tbody> <tr> <td rowspan="3">≥100V</td> <td rowspan="3">≤2.5%</td> <td>≤3.5%</td> <td>0603±0.047μF, 0805±0.1μF, 1206±0.47μF, 1812±4.7μF, 1825±4.7μF, 2220±4.7μF, 2225±4.7μF</td> </tr> <tr> <td>≤5%</td> <td>0603±0.068μF, 0805±0.1μF, 1206±1μF, 1210±2.2μF</td> </tr> <tr> <td>≤10%</td> <td>0805>0.22μF, 1210±3.3μF</td> </tr> <tr> <td rowspan="3">50V</td> <td rowspan="3">≤2.5%</td> <td>≤3.5%</td> <td>0403±0.047μF, 0805±0.1μF, 1206±0.47μF, 1210±2.2μF, 1812±4.7μF, 1825±4.7μF, 2220±4.7μF, 2225±4.7μF</td> </tr> <tr> <td>≤5%</td> <td>1210±4.7μF</td> </tr> <tr> <td>≤10%</td> <td>0402±0.1μF, 0603>0.1μF, 0805±1μF, 1206±2.2μF, 1210±10μF</td> </tr> <tr> <td rowspan="3">35V</td> <td rowspan="3">≤3.5%</td> <td>≤10%</td> <td>0603±1μF, 0805±2.2μF, 1206±2.2μF, 1210±10μF</td> </tr> <tr> <td>≤5%</td> <td>0805±1μF, 1210±10μF</td> </tr> <tr> <td>≤7%</td> <td>0603±0.33μF, 1206±4.7μF</td> </tr> <tr> <td rowspan="3">25V</td> <td rowspan="3">≤3.5%</td> <td>≤10%</td> <td>0402±0.10μF, 0603±0.47μF, 0805±2.2μF, 1206±4.7μF, 1210±22μF</td> </tr> <tr> <td>≤12.5%</td> <td>0402±0.47μF</td> </tr> <tr> <td>≤5%</td> <td>0402±0.033μF, 0603±0.15μF, 0805±0.68μF, 1206±2.2μF, 1210±4.7μF</td> </tr> <tr> <td rowspan="3">16V</td> <td rowspan="3">≤3.5%</td> <td>≤10%</td> <td>0402±0.22μF, 0603±0.68μF, 0805±2.2μF, 1206±4.7μF, 1210±22μF</td> </tr> <tr> <td>≤15%</td> <td>0402±1μF</td> </tr> <tr> <td>≤10%</td> <td>0402±0.33μF, 0402/X7R±0.22μF, 0603±0.33μF, 0805±2.2μF, 1206±2.2μF, 1210±22μF</td> </tr> <tr> <td rowspan="3">10V</td> <td rowspan="3">≤5%</td> <td>≤15%</td> <td>0402±1μF</td> </tr> <tr> <td>≤10%</td> <td>0402±1μF, 0603±10μF, 0805±4.7μF, 1206±4.7μF, 1210±100μF</td> </tr> <tr> <td>≤20%</td> <td>0402±2.2μF</td> </tr> <tr> <td rowspan="3">6.3V</td> <td rowspan="3">≤10%</td> <td>≤15%</td> <td>---</td> </tr> <tr> <td>≤20%</td> <td>---</td> </tr> <tr> <td>---</td> <td>---</td> </tr> <tr> <td rowspan="3">4V</td> <td rowspan="3">≤15%</td> <td>---</td> <td>---</td> </tr> <tr> <td>---</td> <td>---</td> </tr> <tr> <td>---</td> <td>---</td> </tr> </tbody> </table> <p>X5R:</p> <table border="1"> <thead> <tr> <th>RATED</th> <th>D.F.≤</th> <th colspan="2">EXCEPTION OF D.F.≤</th> </tr> </thead> <tbody> <tr> <td rowspan="3">≥100V</td> <td rowspan="3">≤2.5%</td> <td>≤3%</td> <td>1206±0.47μF</td> </tr> <tr> <td>≤5%</td> <td>0603±0.068μF, 0805>0.1μF, 1206>1μF, 1210±2.2μF</td> </tr> <tr> <td>≤10%</td> <td>0805>0.22μF, 1210±3.3μF</td> </tr> <tr> <td rowspan="3">50V</td> <td rowspan="3">≤2.5%</td> <td>≤3%</td> <td>0603±0.047μF, 0805±0.1μF, 1206±0.47μF, 1210±2.2μF, 1812±4.7μF, 1825±4.7μF, 2220±4.7μF, 2225±4.7μF</td> </tr> <tr> <td>≤5%</td> <td>1210±4.7μF</td> </tr> <tr> <td>≤10%</td> <td>0402±0.012μF, 0603>0.1μF, 0805±1μF, 1206±2.2μF, 1210±10μF</td> </tr> <tr> <td rowspan="3">35V</td> <td rowspan="3">≤3.5%</td> <td>≤12.5%</td> <td>1206±2.2μF</td> </tr> <tr> <td>≤10%</td> <td>0603±1μF, 0805±2.2μF, 1206±2.2μF, 1210±10μF</td> </tr> <tr> <td>≤5%</td> <td>0201±0.01μF, 0805±1μF</td> </tr> <tr> <td rowspan="3">25V</td> <td rowspan="3">≤3.5%</td> <td>≤7%</td> <td>0603±0.33μF</td> </tr> <tr> <td>≤10%</td> <td>0201±0.01μF, 0402±0.10μF, 0603±0.47μF, 0805±2.2μF, 1206±4.7μF, 1210±10μF</td> </tr> <tr> <td>≤12.5%</td> <td>0402±0.33μF, 0805±10μF</td> </tr> <tr> <td rowspan="3">16V</td> <td rowspan="3">≤3.5%</td> <td>≤5%</td> <td>0201±0.01μF, 0402±0.033μF, 0603±0.15μF, 0805±0.68μF, 1206±2.2μF, 1210±4.7μF</td> </tr> <tr> <td>≤10%</td> <td>0402±0.22μF, 0603±0.68μF, 0805±2.2μF, 1206±4.7μF, 1210±22μF</td> </tr> <tr> <td>≤12.5%</td> <td>0402±1μF, 0805±2.2μF</td> </tr> <tr> <td rowspan="3">10V</td> <td rowspan="3">≤5%</td> <td>≤10%</td> <td>0201±0.012μF, 0402±0.22μF, 0603±0.33μF, 0805±2.2μF, 1206±2.2μF, 1210±22μF, 01R5/X5R</td> </tr> <tr> <td>≤12.5%</td> <td>0805±10μF</td> </tr> <tr> <td>≤15%</td> <td>0201>0.1μF, 0402±1μF, 0603±10μF</td> </tr> <tr> <td rowspan="3">6.3V</td> <td rowspan="3">≤10%</td> <td>≤15%</td> <td>0201>0.1μF, 0402±1μF, 0603±10μF, 0805±4.7μF, 1206±4.7μF, 1210±100μF</td> </tr> <tr> <td>≤20%</td> <td>0402±2.2μF</td> </tr> <tr> <td>---</td> <td>---</td> </tr> <tr> <td rowspan="3">4V</td> <td rowspan="3">≤15%</td> <td>---</td> <td>---</td> </tr> <tr> <td>---</td> <td>---</td> </tr> <tr> <td>---</td> <td>---</td> </tr> </tbody> </table>	DIELECTRIC	RATED VOL.	Q/D.F	REMARK	Class 1	All	Q ₂ ≥1000	Cap.≥30pF			Q ₂ ≥400+20C	Cap. <30pF	RATED	D.F.≤	EXCEPTION OF D.F.≤		≥100V	≤2.5%	≤3.5%	0603±0.047μF, 0805±0.1μF, 1206±0.47μF, 1812±4.7μF, 1825±4.7μF, 2220±4.7μF, 2225±4.7μF	≤5%	0603±0.068μF, 0805±0.1μF, 1206±1μF, 1210±2.2μF	≤10%	0805>0.22μF, 1210±3.3μF	50V	≤2.5%	≤3.5%	0403±0.047μF, 0805±0.1μF, 1206±0.47μF, 1210±2.2μF, 1812±4.7μF, 1825±4.7μF, 2220±4.7μF, 2225±4.7μF	≤5%	1210±4.7μF	≤10%	0402±0.1μF, 0603>0.1μF, 0805±1μF, 1206±2.2μF, 1210±10μF	35V	≤3.5%	≤10%	0603±1μF, 0805±2.2μF, 1206±2.2μF, 1210±10μF	≤5%	0805±1μF, 1210±10μF	≤7%	0603±0.33μF, 1206±4.7μF	25V	≤3.5%	≤10%	0402±0.10μF, 0603±0.47μF, 0805±2.2μF, 1206±4.7μF, 1210±22μF	≤12.5%	0402±0.47μF	≤5%	0402±0.033μF, 0603±0.15μF, 0805±0.68μF, 1206±2.2μF, 1210±4.7μF	16V	≤3.5%	≤10%	0402±0.22μF, 0603±0.68μF, 0805±2.2μF, 1206±4.7μF, 1210±22μF	≤15%	0402±1μF	≤10%	0402±0.33μF, 0402/X7R±0.22μF, 0603±0.33μF, 0805±2.2μF, 1206±2.2μF, 1210±22μF	10V	≤5%	≤15%	0402±1μF	≤10%	0402±1μF, 0603±10μF, 0805±4.7μF, 1206±4.7μF, 1210±100μF	≤20%	0402±2.2μF	6.3V	≤10%	≤15%	---	≤20%	---	---	---	4V	≤15%	---	---	---	---	---	---	RATED	D.F.≤	EXCEPTION OF D.F.≤		≥100V	≤2.5%	≤3%	1206±0.47μF	≤5%	0603±0.068μF, 0805>0.1μF, 1206>1μF, 1210±2.2μF	≤10%	0805>0.22μF, 1210±3.3μF	50V	≤2.5%	≤3%	0603±0.047μF, 0805±0.1μF, 1206±0.47μF, 1210±2.2μF, 1812±4.7μF, 1825±4.7μF, 2220±4.7μF, 2225±4.7μF	≤5%	1210±4.7μF	≤10%	0402±0.012μF, 0603>0.1μF, 0805±1μF, 1206±2.2μF, 1210±10μF	35V	≤3.5%	≤12.5%	1206±2.2μF	≤10%	0603±1μF, 0805±2.2μF, 1206±2.2μF, 1210±10μF	≤5%	0201±0.01μF, 0805±1μF	25V	≤3.5%	≤7%	0603±0.33μF	≤10%	0201±0.01μF, 0402±0.10μF, 0603±0.47μF, 0805±2.2μF, 1206±4.7μF, 1210±10μF	≤12.5%	0402±0.33μF, 0805±10μF	16V	≤3.5%	≤5%	0201±0.01μF, 0402±0.033μF, 0603±0.15μF, 0805±0.68μF, 1206±2.2μF, 1210±4.7μF	≤10%	0402±0.22μF, 0603±0.68μF, 0805±2.2μF, 1206±4.7μF, 1210±22μF	≤12.5%	0402±1μF, 0805±2.2μF	10V	≤5%	≤10%	0201±0.012μF, 0402±0.22μF, 0603±0.33μF, 0805±2.2μF, 1206±2.2μF, 1210±22μF, 01R5/X5R	≤12.5%	0805±10μF	≤15%	0201>0.1μF, 0402±1μF, 0603±10μF	6.3V	≤10%	≤15%	0201>0.1μF, 0402±1μF, 0603±10μF, 0805±4.7μF, 1206±4.7μF, 1210±100μF	≤20%	0402±2.2μF	---	---	4V	≤15%	---	---	---	---	---	---
DIELECTRIC	RATED VOL.	Q/D.F	REMARK																																																																																																																																																				
Class 1	All	Q ₂ ≥1000	Cap.≥30pF																																																																																																																																																				
		Q ₂ ≥400+20C	Cap. <30pF																																																																																																																																																				
RATED	D.F.≤	EXCEPTION OF D.F.≤																																																																																																																																																					
≥100V	≤2.5%	≤3.5%	0603±0.047μF, 0805±0.1μF, 1206±0.47μF, 1812±4.7μF, 1825±4.7μF, 2220±4.7μF, 2225±4.7μF																																																																																																																																																				
		≤5%	0603±0.068μF, 0805±0.1μF, 1206±1μF, 1210±2.2μF																																																																																																																																																				
		≤10%	0805>0.22μF, 1210±3.3μF																																																																																																																																																				
50V	≤2.5%	≤3.5%	0403±0.047μF, 0805±0.1μF, 1206±0.47μF, 1210±2.2μF, 1812±4.7μF, 1825±4.7μF, 2220±4.7μF, 2225±4.7μF																																																																																																																																																				
		≤5%	1210±4.7μF																																																																																																																																																				
		≤10%	0402±0.1μF, 0603>0.1μF, 0805±1μF, 1206±2.2μF, 1210±10μF																																																																																																																																																				
35V	≤3.5%	≤10%	0603±1μF, 0805±2.2μF, 1206±2.2μF, 1210±10μF																																																																																																																																																				
		≤5%	0805±1μF, 1210±10μF																																																																																																																																																				
		≤7%	0603±0.33μF, 1206±4.7μF																																																																																																																																																				
25V	≤3.5%	≤10%	0402±0.10μF, 0603±0.47μF, 0805±2.2μF, 1206±4.7μF, 1210±22μF																																																																																																																																																				
		≤12.5%	0402±0.47μF																																																																																																																																																				
		≤5%	0402±0.033μF, 0603±0.15μF, 0805±0.68μF, 1206±2.2μF, 1210±4.7μF																																																																																																																																																				
16V	≤3.5%	≤10%	0402±0.22μF, 0603±0.68μF, 0805±2.2μF, 1206±4.7μF, 1210±22μF																																																																																																																																																				
		≤15%	0402±1μF																																																																																																																																																				
		≤10%	0402±0.33μF, 0402/X7R±0.22μF, 0603±0.33μF, 0805±2.2μF, 1206±2.2μF, 1210±22μF																																																																																																																																																				
10V	≤5%	≤15%	0402±1μF																																																																																																																																																				
		≤10%	0402±1μF, 0603±10μF, 0805±4.7μF, 1206±4.7μF, 1210±100μF																																																																																																																																																				
		≤20%	0402±2.2μF																																																																																																																																																				
6.3V	≤10%	≤15%	---																																																																																																																																																				
		≤20%	---																																																																																																																																																				
		---	---																																																																																																																																																				
4V	≤15%	---	---																																																																																																																																																				
		---	---																																																																																																																																																				
		---	---																																																																																																																																																				
RATED	D.F.≤	EXCEPTION OF D.F.≤																																																																																																																																																					
≥100V	≤2.5%	≤3%	1206±0.47μF																																																																																																																																																				
		≤5%	0603±0.068μF, 0805>0.1μF, 1206>1μF, 1210±2.2μF																																																																																																																																																				
		≤10%	0805>0.22μF, 1210±3.3μF																																																																																																																																																				
50V	≤2.5%	≤3%	0603±0.047μF, 0805±0.1μF, 1206±0.47μF, 1210±2.2μF, 1812±4.7μF, 1825±4.7μF, 2220±4.7μF, 2225±4.7μF																																																																																																																																																				
		≤5%	1210±4.7μF																																																																																																																																																				
		≤10%	0402±0.012μF, 0603>0.1μF, 0805±1μF, 1206±2.2μF, 1210±10μF																																																																																																																																																				
35V	≤3.5%	≤12.5%	1206±2.2μF																																																																																																																																																				
		≤10%	0603±1μF, 0805±2.2μF, 1206±2.2μF, 1210±10μF																																																																																																																																																				
		≤5%	0201±0.01μF, 0805±1μF																																																																																																																																																				
25V	≤3.5%	≤7%	0603±0.33μF																																																																																																																																																				
		≤10%	0201±0.01μF, 0402±0.10μF, 0603±0.47μF, 0805±2.2μF, 1206±4.7μF, 1210±10μF																																																																																																																																																				
		≤12.5%	0402±0.33μF, 0805±10μF																																																																																																																																																				
16V	≤3.5%	≤5%	0201±0.01μF, 0402±0.033μF, 0603±0.15μF, 0805±0.68μF, 1206±2.2μF, 1210±4.7μF																																																																																																																																																				
		≤10%	0402±0.22μF, 0603±0.68μF, 0805±2.2μF, 1206±4.7μF, 1210±22μF																																																																																																																																																				
		≤12.5%	0402±1μF, 0805±2.2μF																																																																																																																																																				
10V	≤5%	≤10%	0201±0.012μF, 0402±0.22μF, 0603±0.33μF, 0805±2.2μF, 1206±2.2μF, 1210±22μF, 01R5/X5R																																																																																																																																																				
		≤12.5%	0805±10μF																																																																																																																																																				
		≤15%	0201>0.1μF, 0402±1μF, 0603±10μF																																																																																																																																																				
6.3V	≤10%	≤15%	0201>0.1μF, 0402±1μF, 0603±10μF, 0805±4.7μF, 1206±4.7μF, 1210±100μF																																																																																																																																																				
		≤20%	0402±2.2μF																																																																																																																																																				
		---	---																																																																																																																																																				
4V	≤15%	---	---																																																																																																																																																				
		---	---																																																																																																																																																				
		---	---																																																																																																																																																				
3.	Q/D.F (Dissipation Factor)	<p>*Before initial measurement (Class II only) : To apply deaging at 150°C for 1hr then set for 24±2 hrs at room temp</p>																																																																																																																																																					
4.	Temperature Coefficient	<p>- With no electrical load.</p> <table border="1"> <thead> <tr> <th>T.C.</th> <th>OPERATING TEMPERATURE</th> </tr> </thead> <tbody> <tr> <td>COG</td> <td>-55~125°C at 25°C</td> </tr> <tr> <td>X7R</td> <td>-55~125°C at 25°C</td> </tr> <tr> <td>X7S</td> <td>-55~125°C at 25°C</td> </tr> <tr> <td>X5R</td> <td>-55~85°C at 25°C</td> </tr> </tbody> </table> <p>- Measurement voltage for Class II:</p> <table border="1"> <thead> <tr> <th>SIZE</th> <th>CAP. RANGE</th> <th>CONDITION</th> </tr> </thead> <tbody> <tr> <td rowspan="4">0402</td> <td>Cap.<0.1μF</td> <td>1V</td> </tr> <tr> <td>Cap.=1μF</td> <td>0.5V</td> </tr> <tr> <td>1μF<Cap.<10μF</td> <td>0.2V</td> </tr> <tr> <td>Cap.≥10μF</td> <td>0.1V</td> </tr> <tr> <td rowspan="3">0603</td> <td>Cap.≤1μF</td> <td>1V</td> </tr> <tr> <td>1μF<Cap.≤4.7μF</td> <td>0.5V</td> </tr> <tr> <td>Cap.>4.7μF</td> <td>0.2V</td> </tr> <tr> <td rowspan="3">0805</td> <td>Cap.<10μF</td> <td>1V</td> </tr> <tr> <td>Cap.=10μF</td> <td>0.5V</td> </tr> <tr> <td>Cap.>10μF</td> <td>0.2V</td> </tr> <tr> <td rowspan="3">1206/1210</td> <td>Cap.≤10μF</td> <td>1V</td> </tr> <tr> <td>10μF<Cap.≤100μF</td> <td>0.5V</td> </tr> <tr> <td>Cap.>100μF</td> <td>0.2V</td> </tr> </tbody> </table>	T.C.	OPERATING TEMPERATURE	COG	-55~125°C at 25°C	X7R	-55~125°C at 25°C	X7S	-55~125°C at 25°C	X5R	-55~85°C at 25°C	SIZE	CAP. RANGE	CONDITION	0402	Cap.<0.1μF	1V	Cap.=1μF	0.5V	1μF<Cap.<10μF	0.2V	Cap.≥10μF	0.1V	0603	Cap.≤1μF	1V	1μF<Cap.≤4.7μF	0.5V	Cap.>4.7μF	0.2V	0805	Cap.<10μF	1V	Cap.=10μF	0.5V	Cap.>10μF	0.2V	1206/1210	Cap.≤10μF	1V	10μF<Cap.≤100μF	0.5V	Cap.>100μF	0.2V	<p>-No evidence of damage or flash over during test.</p> <table border="1"> <thead> <tr> <th>T.C.</th> <th>CAPACITANCE CHANGE</th> </tr> </thead> <tbody> <tr> <td>COG</td> <td>Within ±30ppm/°C</td> </tr> <tr> <td>X7R</td> <td>Within ±15%</td> </tr> <tr> <td>X7S</td> <td>Within ±22%</td> </tr> <tr> <td>X5R</td> <td>Within ±15%</td> </tr> </tbody> </table>	T.C.	CAPACITANCE CHANGE	COG	Within ±30ppm/°C	X7R	Within ±15%	X7S	Within ±22%	X5R	Within ±15%																																																																																															
T.C.	OPERATING TEMPERATURE																																																																																																																																																						
COG	-55~125°C at 25°C																																																																																																																																																						
X7R	-55~125°C at 25°C																																																																																																																																																						
X7S	-55~125°C at 25°C																																																																																																																																																						
X5R	-55~85°C at 25°C																																																																																																																																																						
SIZE	CAP. RANGE	CONDITION																																																																																																																																																					
0402	Cap.<0.1μF	1V																																																																																																																																																					
	Cap.=1μF	0.5V																																																																																																																																																					
	1μF<Cap.<10μF	0.2V																																																																																																																																																					
	Cap.≥10μF	0.1V																																																																																																																																																					
0603	Cap.≤1μF	1V																																																																																																																																																					
	1μF<Cap.≤4.7μF	0.5V																																																																																																																																																					
	Cap.>4.7μF	0.2V																																																																																																																																																					
0805	Cap.<10μF	1V																																																																																																																																																					
	Cap.=10μF	0.5V																																																																																																																																																					
	Cap.>10μF	0.2V																																																																																																																																																					
1206/1210	Cap.≤10μF	1V																																																																																																																																																					
	10μF<Cap.≤100μF	0.5V																																																																																																																																																					
	Cap.>100μF	0.2V																																																																																																																																																					
T.C.	CAPACITANCE CHANGE																																																																																																																																																						
COG	Within ±30ppm/°C																																																																																																																																																						
X7R	Within ±15%																																																																																																																																																						
X7S	Within ±22%																																																																																																																																																						
X5R	Within ±15%																																																																																																																																																						



RELIABILITY TEST CONDITIONS AND REQUIREMENTS

NO.	ITEM	TEST CONDITION	REQUIREMENTS																																														
5.	Insulation Resistance	<table border="1" data-bbox="373 409 714 493"> <thead> <tr> <th>RATED VOL. (V)</th> <th>APPLY VOLTAGE</th> <th>CHARGE TIME</th> </tr> </thead> <tbody> <tr> <td>≤100</td> <td>1 times of U_r</td> <td>Max. 120 sec.</td> </tr> <tr> <td>200≤V≤500</td> <td>1 times of U_r</td> <td>60 sec.</td> </tr> <tr> <td>>500</td> <td>500Vdc</td> <td>60 sec.</td> </tr> </tbody> </table>	RATED VOL. (V)	APPLY VOLTAGE	CHARGE TIME	≤100	1 times of U_r	Max. 120 sec.	200≤V≤500	1 times of U_r	60 sec.	>500	500Vdc	60 sec.	<p>-No evidence of damage or flash over during test.</p> <table border="1" data-bbox="990 210 1331 273"> <thead> <tr> <th>DIELECTRIC</th> <th>CAPACITANCE RANGE</th> </tr> </thead> <tbody> <tr> <td>Class I</td> <td>≥10GΩ or RxC≥5000-F, whichever is smaller</td> </tr> <tr> <td>Class II</td> <td>≥10GΩ or RxC≥1000-F, whichever is smaller</td> </tr> </tbody> </table> <p>- Except (Class II)</p> <table border="1" data-bbox="885 304 1437 766"> <thead> <tr> <th>RATED VOLTAGE (X7R)</th> <th>I.R.</th> </tr> </thead> <tbody> <tr> <td>≥10GΩ or RxC≥1000-F, whichever is smaller</td> <td rowspan="10">≥10GΩ or RxC≥1000-F, whichever is smaller</td> </tr> <tr> <td>50V : 0402≥0.01μF, 0603≥1μF, 0805≥1μF, 1206≥4.7μF, 1210≥4.7μF, 1812≥10μF, 2220≥22μF</td> </tr> <tr> <td>35V : 0805≥2.2μF, 1206≥2.2μF, 1210≥10μF</td> </tr> <tr> <td>25V : 0402≥1μF, 0603≥2.2μF, 0805≥2.2μF, 1206≥10μF, 1210≥10μF</td> </tr> <tr> <td>16V : 0402≥0.22μF, 0603≥1μF, 0805≥2.2μF, 1206≥10μF, 1210≥47μF</td> </tr> <tr> <td>10V : 0402≥0.47μF, 0603≥0.47μF, 0805≥2.2μF, 1206≥4.7μF, 1210≥47μF</td> </tr> <tr> <td>6.3V, 4V</td> </tr> <tr> <th>RATED VOLTAGE (X7R)</th> <th>I.R.</th> </tr> <tr> <td>100V : 1210≥3.3μF</td> <td rowspan="10">RxC≥500-F</td> </tr> <tr> <td>50V : 0402≥0.1μF, 0603≥2.2μF, 0805≥10μF, 1206≥10μF</td> </tr> <tr> <td>35V : 0603≥1μF</td> </tr> <tr> <td>25V : 0402≥2.2μF, 0603≥10μF, 0805≥10μF, 1206≥22μF</td> </tr> <tr> <td>16V : 0603≥10μF, 0402≥1μF, 0201≥0.22μF</td> </tr> <tr> <td>10V : 0402≥1μF, 0603≥10μF, 0805≥47μF</td> </tr> <tr> <td>6.3V : 0603≥4.7μF, 0805≥47μF, 1206≥10μF</td> </tr> <tr> <td>4V : 0603≥22μF, 0805≥47μF, 1206≥100μF</td> </tr> <tr> <th>RATED VOLTAGE (X5R)</th> <th>I.R.</th> </tr> <tr> <td>25V : 0402>0.1μF, 0603>0.22μF, 0805>1μF, 1206>2.2μF, 1210>4.7μF</td> <td rowspan="5">RxC≥500-F</td> </tr> <tr> <td>16V : 0402>0.033μF, 0603>0.22μF, 0805>1μF, 1206>1.5μF, 1210>1.5μF</td> </tr> <tr> <td>10V : 0402>0.068μF, 0603>0.33μF, 0805>1μF, 1206>1.5μF, 1210>1.5μF</td> </tr> <tr> <td>6.3V : 0402>0.1μF, 0603>0.33μF, 0805>1.5μF, 1206>100μF, 1210>10μF</td> </tr> </tbody> </table>	DIELECTRIC	CAPACITANCE RANGE	Class I	≥10GΩ or RxC≥5000-F, whichever is smaller	Class II	≥10GΩ or RxC≥1000-F, whichever is smaller	RATED VOLTAGE (X7R)	I.R.	≥10GΩ or RxC≥1000-F, whichever is smaller	≥10GΩ or RxC≥1000-F, whichever is smaller	50V : 0402≥0.01μF, 0603≥1μF, 0805≥1μF, 1206≥4.7μF, 1210≥4.7μF, 1812≥10μF, 2220≥22μF	35V : 0805≥2.2μF, 1206≥2.2μF, 1210≥10μF	25V : 0402≥1μF, 0603≥2.2μF, 0805≥2.2μF, 1206≥10μF, 1210≥10μF	16V : 0402≥0.22μF, 0603≥1μF, 0805≥2.2μF, 1206≥10μF, 1210≥47μF	10V : 0402≥0.47μF, 0603≥0.47μF, 0805≥2.2μF, 1206≥4.7μF, 1210≥47μF	6.3V, 4V	RATED VOLTAGE (X7R)	I.R.	100V : 1210≥3.3μF	RxC≥500-F	50V : 0402≥0.1μF, 0603≥2.2μF, 0805≥10μF, 1206≥10μF	35V : 0603≥1μF	25V : 0402≥2.2μF, 0603≥10μF, 0805≥10μF, 1206≥22μF	16V : 0603≥10μF, 0402≥1μF, 0201≥0.22μF	10V : 0402≥1μF, 0603≥10μF, 0805≥47μF	6.3V : 0603≥4.7μF, 0805≥47μF, 1206≥10μF	4V : 0603≥22μF, 0805≥47μF, 1206≥100μF	RATED VOLTAGE (X5R)	I.R.	25V : 0402>0.1μF, 0603>0.22μF, 0805>1μF, 1206>2.2μF, 1210>4.7μF	RxC≥500-F	16V : 0402>0.033μF, 0603>0.22μF, 0805>1μF, 1206>1.5μF, 1210>1.5μF	10V : 0402>0.068μF, 0603>0.33μF, 0805>1μF, 1206>1.5μF, 1210>1.5μF	6.3V : 0402>0.1μF, 0603>0.33μF, 0805>1.5μF, 1206>100μF, 1210>10μF
RATED VOL. (V)	APPLY VOLTAGE	CHARGE TIME																																															
≤100	1 times of U_r	Max. 120 sec.																																															
200≤V≤500	1 times of U_r	60 sec.																																															
>500	500Vdc	60 sec.																																															
DIELECTRIC	CAPACITANCE RANGE																																																
Class I	≥10GΩ or RxC≥5000-F, whichever is smaller																																																
Class II	≥10GΩ or RxC≥1000-F, whichever is smaller																																																
RATED VOLTAGE (X7R)	I.R.																																																
≥10GΩ or RxC≥1000-F, whichever is smaller	≥10GΩ or RxC≥1000-F, whichever is smaller																																																
50V : 0402≥0.01μF, 0603≥1μF, 0805≥1μF, 1206≥4.7μF, 1210≥4.7μF, 1812≥10μF, 2220≥22μF																																																	
35V : 0805≥2.2μF, 1206≥2.2μF, 1210≥10μF																																																	
25V : 0402≥1μF, 0603≥2.2μF, 0805≥2.2μF, 1206≥10μF, 1210≥10μF																																																	
16V : 0402≥0.22μF, 0603≥1μF, 0805≥2.2μF, 1206≥10μF, 1210≥47μF																																																	
10V : 0402≥0.47μF, 0603≥0.47μF, 0805≥2.2μF, 1206≥4.7μF, 1210≥47μF																																																	
6.3V, 4V																																																	
RATED VOLTAGE (X7R)		I.R.																																															
100V : 1210≥3.3μF		RxC≥500-F																																															
50V : 0402≥0.1μF, 0603≥2.2μF, 0805≥10μF, 1206≥10μF																																																	
35V : 0603≥1μF																																																	
25V : 0402≥2.2μF, 0603≥10μF, 0805≥10μF, 1206≥22μF																																																	
16V : 0603≥10μF, 0402≥1μF, 0201≥0.22μF																																																	
10V : 0402≥1μF, 0603≥10μF, 0805≥47μF																																																	
6.3V : 0603≥4.7μF, 0805≥47μF, 1206≥10μF																																																	
4V : 0603≥22μF, 0805≥47μF, 1206≥100μF																																																	
RATED VOLTAGE (X5R)	I.R.																																																
25V : 0402>0.1μF, 0603>0.22μF, 0805>1μF, 1206>2.2μF, 1210>4.7μF	RxC≥500-F																																																
16V : 0402>0.033μF, 0603>0.22μF, 0805>1μF, 1206>1.5μF, 1210>1.5μF																																																	
10V : 0402>0.068μF, 0603>0.33μF, 0805>1μF, 1206>1.5μF, 1210>1.5μF																																																	
6.3V : 0402>0.1μF, 0603>0.33μF, 0805>1.5μF, 1206>100μF, 1210>10μF																																																	
6.		Dielectric Strength	<table border="1" data-bbox="251 798 592 934"> <thead> <tr> <th>RATED VOLTAGE</th> <th>CONDITION</th> </tr> </thead> <tbody> <tr> <td>≤100</td> <td>2.5 times of U_r</td> </tr> <tr> <td>100≤V≤500</td> <td>2.0 times of U_r</td> </tr> <tr> <td>250≤V≤500</td> <td>1.5 times of U_r</td> </tr> <tr> <td>630≤V≤3000V</td> <td>1.2 times of U_r</td> </tr> <tr> <td>3000<V<5000V</td> <td>1.1 times of U_r</td> </tr> <tr> <td>≥5000V</td> <td>1.0 times of U_r</td> </tr> </tbody> </table> <p>- Duration : 1 to 5 sec. Voltage ramp up rate ≤500Vdc/sec. - Charge and discharge current less than 50mA. - Test in insulating fluid for rated voltage ≥1KV products</p>	RATED VOLTAGE	CONDITION	≤100	2.5 times of U_r	100≤V≤500	2.0 times of U_r	250≤V≤500	1.5 times of U_r	630≤V≤3000V	1.2 times of U_r	3000<V<5000V	1.1 times of U_r	≥5000V	1.0 times of U_r	<p>- No evidence of damage or flash over during test.</p>																															
RATED VOLTAGE	CONDITION																																																
≤100	2.5 times of U_r																																																
100≤V≤500	2.0 times of U_r																																																
250≤V≤500	1.5 times of U_r																																																
630≤V≤3000V	1.2 times of U_r																																																
3000<V<5000V	1.1 times of U_r																																																
≥5000V	1.0 times of U_r																																																
7.	Solderability	<p>- Solder temperature : 235±5°C for (0402~1210). - Solder temperature : 245±5°C for (1808~2225). - Dipping time : 2±0.5 sec.</p>	<p>- 75% min. coverage of all metalized area</p>																																														
8.	Resistance to Soldering Heat	<p>- Solder temperature : 260±5°C. - Dipping time : 10±1 sec. - Preheating : 120 to 150°C for 1 minute before immerse the capacitor in a eutectic solder. - Before initial measurement (Class II only) : To apply de-aging at 150°C for 1hr then set for 24±2 hrs at room temp. - Measurement to be made after keeping at room temp. for 24±2 hrs (Class I) or 48±4 hrs (Class II).</p>	<p>- No remarkable damage. - Cap. change : COG : Within ±2.5% or ±0.25pF, whichever is larger. X7R, X7S, X5R : Within ±7.5%. - D.F./Q, I.R. : To meet initial requirements. - 25% max. leaching on each edge.</p>																																														
9.	Temperature Cycle	<p>- Conduct the five cycles according to the temperatures and time</p> <p>- Before initial measurement (Class II only) : To apply de-aging at 150°C for 1hr then set for 24±2 hrs at room temp. - Measurement to be made after keeping at room temp. for 24±2 hrs (Class I) or 48±4 hrs (Class II).</p>	<p>- No remarkable damage. - Cap. change : COG : Within ±2.5% or ±0.25pF, whichever is larger. X7R, X7S, X5R : Within ±7.5%. - D.F./Q : COG : Q≥100% of initial requirements. X7R, X7S, X5R : D.F.≤150% of initial requirement. - I.R. : ≥100% of initial requirement.</p>																																														



RELIABILITY TEST CONDITIONS AND REQUIREMENTS

NO.	ITEM	TEST CONDITION	REQUIREMENTS											
10.	Humidity (Damp Heat) Steady State	<ul style="list-style-type: none"> - Test temp. : 40±2°C. - Humidity : 90~95%RH. - Test time : 500 +24/-0hrs. - Before initial measurement (Class II only) : To apply de-aging at 150°C for 1hr then set for 24±2 hrs at room temp. - Measurement to be made after keeping at room temp. for 24±2 hrs (Class I) or 48±4 hrs (Class II). 	<ul style="list-style-type: none"> - No remarkable damage. - Cap. change : COG : Within ±5.0% or ±0.5pF, whichever is larger. X7R, X7S, X5R : Within ±12.5% for ≥10V**, within ±25% for 6.3V. **10V : Within ±25% for 0603≥4.7μF, 0402≥1μF. - D.F./Q : COG : Q≥350 for Cap.>30pF, Q≥275+2.5C for 10pF≤Cap.≤30pF, Q≥200+10C for Cap.<10pF. X7R, X7S, X5R : D.F.≤200% of initial requirement. - I.R. : ≥10V, ≥1GΩ or RxC≥50Ω-F, whichever is smaller <p>Except:</p> <table border="1"> <thead> <tr> <th>RATED VOLTAGE (X7R, X7S, X5R)</th> <th>I.R.</th> </tr> </thead> <tbody> <tr> <td>100V : All X7R; 1210≥3.3μF</td> <td rowspan="6">≥1GΩ or RxC ≥ 10Ω-F, whichever is smaller</td> </tr> <tr> <td>50V : 0402>0.01μF, 0603≥1μF, 0805≥1μF, 1206≥4.7μF, 1210≥4.7μF</td> </tr> <tr> <td>35V : 0603≥1μF, 0805≥2.2μF, 1206≥2.2μF, 1210≥10μF</td> </tr> <tr> <td>25V : 0402≥0.22μF, 0603≥2.2μF, 0805≥2.2μF, 1206≥10μF, 1210≥10μF</td> </tr> <tr> <td>16V : 0402≥0.22μF, 0603≥1μF, 0805≥2.2μF, 1206≥10μF, 1210≥47μF</td> </tr> <tr> <td>10V : 0402≥0.47μF, 0603≥0.47μF, 0805≥2.2μF, 1206≥4.7μF, 1210≥47μF</td> </tr> <tr> <td>6.3V, 4V; Size≥1812</td> <td></td> </tr> </tbody> </table>	RATED VOLTAGE (X7R, X7S, X5R)	I.R.	100V : All X7R; 1210≥3.3μF	≥1GΩ or RxC ≥ 10Ω-F, whichever is smaller	50V : 0402>0.01μF, 0603≥1μF, 0805≥1μF, 1206≥4.7μF, 1210≥4.7μF	35V : 0603≥1μF, 0805≥2.2μF, 1206≥2.2μF, 1210≥10μF	25V : 0402≥0.22μF, 0603≥2.2μF, 0805≥2.2μF, 1206≥10μF, 1210≥10μF	16V : 0402≥0.22μF, 0603≥1μF, 0805≥2.2μF, 1206≥10μF, 1210≥47μF	10V : 0402≥0.47μF, 0603≥0.47μF, 0805≥2.2μF, 1206≥4.7μF, 1210≥47μF	6.3V, 4V; Size≥1812	
RATED VOLTAGE (X7R, X7S, X5R)	I.R.													
100V : All X7R; 1210≥3.3μF	≥1GΩ or RxC ≥ 10Ω-F, whichever is smaller													
50V : 0402>0.01μF, 0603≥1μF, 0805≥1μF, 1206≥4.7μF, 1210≥4.7μF														
35V : 0603≥1μF, 0805≥2.2μF, 1206≥2.2μF, 1210≥10μF														
25V : 0402≥0.22μF, 0603≥2.2μF, 0805≥2.2μF, 1206≥10μF, 1210≥10μF														
16V : 0402≥0.22μF, 0603≥1μF, 0805≥2.2μF, 1206≥10μF, 1210≥47μF														
10V : 0402≥0.47μF, 0603≥0.47μF, 0805≥2.2μF, 1206≥4.7μF, 1210≥47μF														
6.3V, 4V; Size≥1812														
11.	Humidity (Damp Heat) Load	<ul style="list-style-type: none"> - Reflow solder the capacitors on a P.C. Board before test. - Test temp. : 40±2°C (85±3°C for control code H). - Humidity : 90~95% RH (85±5% for control code H). - Test time : 500 +24/-0hrs. - To apply voltage : Rated voltage (500Vdc max. for general purpose and 100Vdc max. for control code H) - Measurement to be made after keeping at room temp. for 24±2 hrs (Class I) or 48±4 hrs (Class II). 	<ul style="list-style-type: none"> - No remarkable damage. - Cap. change : COG : Within ±7.5% or ±0.75pF, whichever is larger. X7R, X7S, X5R : Within ±12.5% for ≥10V**, within ±25% for 6.3V. **10V : Within ±25% for 0603≥4.7μF, 0402≥1μF. - D.F./Q : COG : Q≥350 for Cap.>30pF, Q≥275+2.5C for 10pF≤Cap.≤30pF, Q≥200+10C for Cap.<10pF. X7R, X7S, X5R : ≤200% of initial requirement. - I.R. : ≥10V, ≥500MΩ or RxC≥25Ω-F, whichever is smaller. <p>Except:</p> <table border="1"> <thead> <tr> <th>RATED VOLTAGE (X7R, X7S, X5R)</th> <th>I.R.</th> </tr> </thead> <tbody> <tr> <td>≥100V : All X7R; 1210≥3.3μF</td> <td rowspan="6">≥500MΩ or RxC≥5Ω-F, whichever is smaller</td> </tr> <tr> <td>50V : 0402>0.01μF, 0603≥1μF, 0805≥1μF, 1206≥4.7μF, 1210≥4.7μF</td> </tr> <tr> <td>35V : 0603≥1μF, 0805≥2.2μF, 1206≥2.2μF, 1210≥10μF</td> </tr> <tr> <td>25V : 0402≥0.22μF, 0603≥2.2μF, 0805≥2.2μF, 1206≥10μF, 1210≥10μF</td> </tr> <tr> <td>16V : 0402≥0.22μF, 0603≥1μF, 0805≥2.2μF, 1206≥10μF, 1210≥47μF</td> </tr> <tr> <td>10V : 0402≥0.47μF, 0603≥0.47μF, 0805≥2.2μF, 1206≥4.7μF, 1210≥47μF</td> </tr> <tr> <td>6.3V, 4V; Size≥1812</td> <td></td> </tr> </tbody> </table>	RATED VOLTAGE (X7R, X7S, X5R)	I.R.	≥100V : All X7R; 1210≥3.3μF	≥500MΩ or RxC≥5Ω-F, whichever is smaller	50V : 0402>0.01μF, 0603≥1μF, 0805≥1μF, 1206≥4.7μF, 1210≥4.7μF	35V : 0603≥1μF, 0805≥2.2μF, 1206≥2.2μF, 1210≥10μF	25V : 0402≥0.22μF, 0603≥2.2μF, 0805≥2.2μF, 1206≥10μF, 1210≥10μF	16V : 0402≥0.22μF, 0603≥1μF, 0805≥2.2μF, 1206≥10μF, 1210≥47μF	10V : 0402≥0.47μF, 0603≥0.47μF, 0805≥2.2μF, 1206≥4.7μF, 1210≥47μF	6.3V, 4V; Size≥1812	
RATED VOLTAGE (X7R, X7S, X5R)	I.R.													
≥100V : All X7R; 1210≥3.3μF	≥500MΩ or RxC≥5Ω-F, whichever is smaller													
50V : 0402>0.01μF, 0603≥1μF, 0805≥1μF, 1206≥4.7μF, 1210≥4.7μF														
35V : 0603≥1μF, 0805≥2.2μF, 1206≥2.2μF, 1210≥10μF														
25V : 0402≥0.22μF, 0603≥2.2μF, 0805≥2.2μF, 1206≥10μF, 1210≥10μF														
16V : 0402≥0.22μF, 0603≥1μF, 0805≥2.2μF, 1206≥10μF, 1210≥47μF														
10V : 0402≥0.47μF, 0603≥0.47μF, 0805≥2.2μF, 1206≥4.7μF, 1210≥47μF														
6.3V, 4V; Size≥1812														



NO.	ITEM	TEST CONDITION	REQUIREMENTS																																																																			
12.	High Temperature Load (Endurance)	- Test temp. : 125±3°C. - To apply voltage : (1) ≤6.3V or Cap.≥10μF : 150% of rated voltage. (2) 10V≤Ur≤100V : 200% of rated voltage. (3) 200V≤Ur≤500V : 150% of rated voltage. (4) 630V : 120% of rated voltage. (5) Ur≥1000V : 100% of rated voltage. (6) 100% of rated voltage for below range:	- No remarkable damage. - Cap. change : COG : Within ±5.0% or ±0.5pF, whichever is larger. X7R, X5R : Within ±12.5% for ≥10V**, within ±25% for 6.3V. **10V : Within ±25% for 0603≥4.7μF, 0402≥1μF. - D.F./Q : COG : Q≥350 for Cap.>30pF, Q≥275+2.5C for 10pF≤Cap.≤30pF, Q≥200+10C for Cap.<10pF. X7R, X5R : D.F.≤200% of initial requirement. - I.R. : ≥10V, ≥1GΩ or RxC≥50Ω-F, whichever is smaller.																																																																			
		<table border="1"> <thead> <tr> <th>SIZE</th> <th>DIELECTRIC</th> <th>RATED</th> <th>CAPACITANCE</th> </tr> </thead> <tbody> <tr> <td rowspan="2">0402</td> <td rowspan="2">X7R / X7S</td> <td>6.3V, 10V, 16V, 25V</td> <td>C≥1.0μF</td> </tr> <tr> <td>4V</td> <td>C≥22μF</td> </tr> <tr> <td rowspan="2">0603</td> <td rowspan="2">X7R / X7S</td> <td>6.3V, 10V</td> <td>C≥4.7μF</td> </tr> <tr> <td>25V, 35V</td> <td>C≥1.0μF</td> </tr> <tr> <td rowspan="3">0805</td> <td rowspan="3">X7R / X7S</td> <td>4V</td> <td>C≥47μF</td> </tr> <tr> <td>6.3V</td> <td>C≥22μF</td> </tr> <tr> <td>10V-50V</td> <td>C≥10μF</td> </tr> <tr> <td rowspan="2">1206</td> <td rowspan="2">X7R / X7S</td> <td>≤6.3V</td> <td>C≥47μF</td> </tr> <tr> <td>100V</td> <td>C≥2.2μF</td> </tr> <tr> <td rowspan="2">1210</td> <td rowspan="2">X7R / X7S</td> <td>16V</td> <td>C≥47μF</td> </tr> <tr> <td>≥100V</td> <td>C≥3.3μF</td> </tr> <tr> <td>2220</td> <td>X7R / X7S</td> <td>100V</td> <td>C≥22μF</td> </tr> </tbody> </table>	SIZE	DIELECTRIC	RATED	CAPACITANCE	0402	X7R / X7S	6.3V, 10V, 16V, 25V	C≥1.0μF	4V	C≥22μF	0603	X7R / X7S	6.3V, 10V	C≥4.7μF	25V, 35V	C≥1.0μF	0805	X7R / X7S	4V	C≥47μF	6.3V	C≥22μF	10V-50V	C≥10μF	1206	X7R / X7S	≤6.3V	C≥47μF	100V	C≥2.2μF	1210	X7R / X7S	16V	C≥47μF	≥100V	C≥3.3μF	2220	X7R / X7S	100V	C≥22μF	Except:																											
		SIZE	DIELECTRIC	RATED	CAPACITANCE																																																																	
		0402	X7R / X7S	6.3V, 10V, 16V, 25V	C≥1.0μF																																																																	
				4V	C≥22μF																																																																	
		0603	X7R / X7S	6.3V, 10V	C≥4.7μF																																																																	
				25V, 35V	C≥1.0μF																																																																	
		0805	X7R / X7S	4V	C≥47μF																																																																	
				6.3V	C≥22μF																																																																	
				10V-50V	C≥10μF																																																																	
		1206	X7R / X7S	≤6.3V	C≥47μF																																																																	
				100V	C≥2.2μF																																																																	
1210	X7R / X7S	16V	C≥47μF																																																																			
		≥100V	C≥3.3μF																																																																			
2220	X7R / X7S	100V	C≥22μF																																																																			
(7) 150% of rated voltage for below range:	<table border="1"> <thead> <tr> <th>SIZE</th> <th>DIELECTRIC</th> <th>RATED</th> <th>CAPACITANCE</th> </tr> </thead> <tbody> <tr> <td rowspan="3">0402</td> <td rowspan="3">X7R / X7S</td> <td>50V</td> <td>C≥0.1μF</td> </tr> <tr> <td>10-25V</td> <td>C≥0.22μF</td> </tr> <tr> <td>≤16V</td> <td>C≥1.0μF</td> </tr> <tr> <td rowspan="2">0603</td> <td rowspan="2">X7R / X7S</td> <td>25V, 50V</td> <td>C≥1.0μF</td> </tr> <tr> <td>≥50V</td> <td>C≥0.082μF</td> </tr> <tr> <td rowspan="3">0805</td> <td rowspan="3">X7R / X7S</td> <td>10V, 16V, 50V</td> <td>C≥1.0μF</td> </tr> <tr> <td>4V</td> <td>C≥22μF</td> </tr> <tr> <td>10-50V</td> <td>C≥4.7μF</td> </tr> <tr> <td rowspan="3">1206</td> <td rowspan="3">X7R / X7S</td> <td>50V</td> <td>C≥0.47μF</td> </tr> <tr> <td>≥100V</td> <td>C≥0.12μF</td> </tr> <tr> <td>16V, 25V</td> <td>C≥22μF</td> </tr> <tr> <td rowspan="2">1210</td> <td rowspan="2">X7R / X7S</td> <td>≥50V</td> <td>C≥1.0μF</td> </tr> <tr> <td>≤6.3V</td> <td>C≥47μF</td> </tr> <tr> <td rowspan="2">1812</td> <td rowspan="2">X7R / X7S</td> <td>≤100V</td> <td>C≥1.0μF</td> </tr> <tr> <td>>100V</td> <td>C≥0.22μF</td> </tr> <tr> <td>2220</td> <td>X7R / X7S</td> <td>16V</td> <td>C≥47μF</td> </tr> <tr> <td>2225</td> <td>X7R / X7S</td> <td>≤50V</td> <td>C≥4.7μF</td> </tr> <tr> <td>2225</td> <td>X7R / X7S</td> <td>100V</td> <td>C≥1.0μF</td> </tr> </tbody> </table>	SIZE	DIELECTRIC	RATED	CAPACITANCE	0402	X7R / X7S	50V	C≥0.1μF	10-25V	C≥0.22μF	≤16V	C≥1.0μF	0603	X7R / X7S	25V, 50V	C≥1.0μF	≥50V	C≥0.082μF	0805	X7R / X7S	10V, 16V, 50V	C≥1.0μF	4V	C≥22μF	10-50V	C≥4.7μF	1206	X7R / X7S	50V	C≥0.47μF	≥100V	C≥0.12μF	16V, 25V	C≥22μF	1210	X7R / X7S	≥50V	C≥1.0μF	≤6.3V	C≥47μF	1812	X7R / X7S	≤100V	C≥1.0μF	>100V	C≥0.22μF	2220	X7R / X7S	16V	C≥47μF	2225	X7R / X7S	≤50V	C≥4.7μF	2225	X7R / X7S	100V	C≥1.0μF	<table border="1"> <thead> <tr> <th>RATED VOLTAGE</th> <th>I.R.</th> </tr> </thead> <tbody> <tr> <td>100V : All X7R; 1210≥3.3μF</td> <td rowspan="10">≥1GΩ or RxC≥100-F, whichever is smaller</td> </tr> <tr> <td>50V : 0402>0.1μF, 0603≥1μF, 0805≥1μF, 1206≥4.7μF, 1210≥4.7μF</td> </tr> <tr> <td>35V : 0603≥1μF, 0805≥2.2μF, 1206≥2.2μF, 1210≥10μF</td> </tr> <tr> <td>25V : 0402≥0.22μF, 0603≥2.2μF, 0805≥2.2μF, 1206≥10μF, 1210≥10μF</td> </tr> <tr> <td>16V : 0402≥0.22μF, 0603≥1μF, 0805≥2.2μF, 1206≥10μF, 1210≥47μF</td> </tr> <tr> <td>10V : 0402≥0.47μF, 0603≥0.47μF, 0805≥2.2μF, 1206≥4.7μF, 1210≥47μF</td> </tr> <tr> <td>6.3V, 4V, Size≥1812</td> </tr> </tbody> </table>	RATED VOLTAGE	I.R.	100V : All X7R; 1210≥3.3μF	≥1GΩ or RxC≥100-F, whichever is smaller	50V : 0402>0.1μF, 0603≥1μF, 0805≥1μF, 1206≥4.7μF, 1210≥4.7μF	35V : 0603≥1μF, 0805≥2.2μF, 1206≥2.2μF, 1210≥10μF	25V : 0402≥0.22μF, 0603≥2.2μF, 0805≥2.2μF, 1206≥10μF, 1210≥10μF	16V : 0402≥0.22μF, 0603≥1μF, 0805≥2.2μF, 1206≥10μF, 1210≥47μF	10V : 0402≥0.47μF, 0603≥0.47μF, 0805≥2.2μF, 1206≥4.7μF, 1210≥47μF	6.3V, 4V, Size≥1812
SIZE	DIELECTRIC	RATED	CAPACITANCE																																																																			
0402	X7R / X7S	50V	C≥0.1μF																																																																			
		10-25V	C≥0.22μF																																																																			
		≤16V	C≥1.0μF																																																																			
0603	X7R / X7S	25V, 50V	C≥1.0μF																																																																			
		≥50V	C≥0.082μF																																																																			
0805	X7R / X7S	10V, 16V, 50V	C≥1.0μF																																																																			
		4V	C≥22μF																																																																			
		10-50V	C≥4.7μF																																																																			
1206	X7R / X7S	50V	C≥0.47μF																																																																			
		≥100V	C≥0.12μF																																																																			
		16V, 25V	C≥22μF																																																																			
1210	X7R / X7S	≥50V	C≥1.0μF																																																																			
		≤6.3V	C≥47μF																																																																			
1812	X7R / X7S	≤100V	C≥1.0μF																																																																			
		>100V	C≥0.22μF																																																																			
2220	X7R / X7S	16V	C≥47μF																																																																			
2225	X7R / X7S	≤50V	C≥4.7μF																																																																			
2225	X7R / X7S	100V	C≥1.0μF																																																																			
RATED VOLTAGE	I.R.																																																																					
100V : All X7R; 1210≥3.3μF	≥1GΩ or RxC≥100-F, whichever is smaller																																																																					
50V : 0402>0.1μF, 0603≥1μF, 0805≥1μF, 1206≥4.7μF, 1210≥4.7μF																																																																						
35V : 0603≥1μF, 0805≥2.2μF, 1206≥2.2μF, 1210≥10μF																																																																						
25V : 0402≥0.22μF, 0603≥2.2μF, 0805≥2.2μF, 1206≥10μF, 1210≥10μF																																																																						
16V : 0402≥0.22μF, 0603≥1μF, 0805≥2.2μF, 1206≥10μF, 1210≥47μF																																																																						
10V : 0402≥0.47μF, 0603≥0.47μF, 0805≥2.2μF, 1206≥4.7μF, 1210≥47μF																																																																						
6.3V, 4V, Size≥1812																																																																						
(8) 120% of rated voltage for below range:		<table border="1"> <thead> <tr> <th>SIZE</th> <th>DIELECTRIC</th> <th>RATED</th> <th>CAPACITANCE</th> </tr> </thead> <tbody> <tr> <td>2220</td> <td>X7R / X7S</td> <td>≥100V</td> <td>C≥15μF</td> </tr> </tbody> </table>	SIZE	DIELECTRIC	RATED	CAPACITANCE	2220	X7R / X7S	≥100V	C≥15μF																																																												
SIZE		DIELECTRIC	RATED	CAPACITANCE																																																																		
2220		X7R / X7S	≥100V	C≥15μF																																																																		
	- Test time : 1000 +24/-0 hrs. - Before initial measurement (Class II only) : To apply deaging at 150°C for 1hr then set for 24±2 hrs at room temp. - Measurement to be made after keeping at room temp. for 48±4 hrs (Class II). - De-rating conditions :																																																																					
	<p>The graph plots the Ratio Operating Voltage (R) on the y-axis (0 to 120) against the Temperature at Product (C) on the x-axis (0 to 150). Three curves are shown: a solid line for 125°C (constant at 100 until 100°C, then decreasing), a dashed line for 105°C (constant at 100 until 75°C, then decreasing), and a dotted line for 85°C (constant at 100 until 50°C, then decreasing).</p>																																																																					

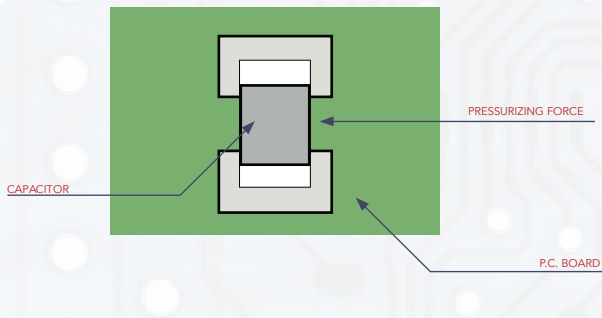
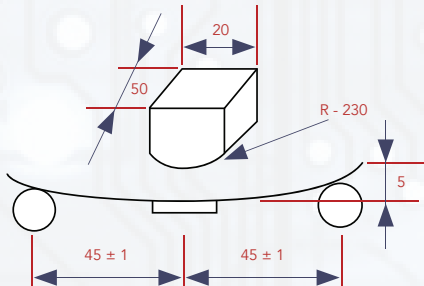

RELIABILITY TEST CONDITIONS AND REQUIREMENTS

NO.	ITEM	TEST CONDITION	REQUIREMENTS						
13.	Adhesive Strength of Termination	<p>- Capacitors mounted on a substrate. A force of 5N(≤ 0603) or 10N(>0603) applied perpendicular to the place of substrate and parallel the line joining the center of terminations for 10 ± 1 second</p> 	<p>- No remarkable damage or removal of the terminations</p>						
14.	Bending Test	<p>- The middle part of substrate shall be pressurized by means of the pressurizing rod at a rate of about 1mm per second until the deflection becomes 5mm for product size < 1808, 3mm for product size ≥ 1808</p> 	<p>- No remarkable damage.</p> <table border="1" data-bbox="966 640 1550 745"> <thead> <tr> <th>DIELECTRIC</th> <th>CAP. CHANGE</th> </tr> </thead> <tbody> <tr> <td>Class I (C0G)</td> <td>Within $\pm 5.0\%$ or $\pm 0.5\text{pF}$, whichever is larger</td> </tr> <tr> <td>Class II (X7R, X7S, X5R)</td> <td>Within $\pm 12.5\%$</td> </tr> </tbody> </table> <p>- This capacitance change means the change of capacitance under specified flexure of substrate from the before test initial measurement</p>	DIELECTRIC	CAP. CHANGE	Class I (C0G)	Within $\pm 5.0\%$ or $\pm 0.5\text{pF}$, whichever is larger	Class II (X7R, X7S, X5R)	Within $\pm 12.5\%$
DIELECTRIC	CAP. CHANGE								
Class I (C0G)	Within $\pm 5.0\%$ or $\pm 0.5\text{pF}$, whichever is larger								
Class II (X7R, X7S, X5R)	Within $\pm 12.5\%$								
15.	Vibration Resistance	<p>- Vibration frequency : 10~55 Hz/min. - Total amplitude : 1.5mm. - Test time : 6 hrs. (Two hrs each in three mutually perpendicular directions) - Before initial measurement (Class II only) : To apply de-aging at 150°C for 1hr then set for 24 ± 2 hrs at room temp. - Measurement to be made after keeping at room temp. for 24 ± 2 hrs (Class I) or 48 ± 4 hrs (Class II).</p>	<p>- No remarkable damage or removal of the terminations - Cap. change and D.F./Q : To meet initial spec.</p>						





PACKAGE DIMENSION AND QUANTITY

SIZE	THICKNESS (MM)	PAPER TAPE		PLASTIC TAPE	
		7" REEL	13" REEL	7" REEL	13" REEL
0402 (1005)	0.50±0.05	10K	50K	-	-
	0.50 +0.02/-0.05	10K	50K	-	-
	0.50±0.20	10K	-	-	-
0603 (1608)	0.50±0.10	4K	-	-	-
	0.80±0.07	4K	15K	-	-
	0.80 +0.15/-0.10	4K	15K	-	-
0805 (2012)	0.50±0.10	4K	15K	-	-
	0.60±0.10	4K	15K	-	-
	0.80±0.10	4K	15K	-	-
	0.85±0.10	4K	15K	-	-
	1.25±0.10	-	-	3K	10K
	1.25±0.20	-	-	3K	10K
	1.60±0.10	4K	15K	-	-
1206 (3216)	0.85±0.10	4K	15K	-	-
	0.85±0.10	4K	15K	-	-
	0.95±0.10	-	-	3K	10K
	1.15±0.15	-	-	3K	10K
	1.25±0.10	-	-	3K	10K
	1.60±0.20	-	-	2K	10K
	1.60 +0.30/-0.10	-	-	2K	9K
1210 (3225)	0.85±0.10	-	-	3K	10K
	0.95±0.10	-	-	3K	10K
	1.25±0.10	-	-	3K	10K
	1.60±0.20	-	-	2K	-
	2.00±0.20	-	-	1K	6K
	2.50±0.30	-	-	1K	6K
1808 (4520)	1.25±0.10	-	-	2K	10K
	1.60±0.20	-	-	2K	8K
	2.00±0.20	-	-	1K	6K
1812 (4532)	1.25±0.10	-	-	1K	5K
	1.60±0.20	-	-	1K	-
	2.00±0.20	-	-	1K	-
	2.50±0.30	-	-	0.5K	3K
	2.80±0.30	-	-	0.5K	-
1825 (4563)	1.60±0.20	-	-	1K	-
	2.00±0.20	-	-	1K	-
	2.50±0.30	-	-	0.5K	-
	2.80±0.30	-	-	0.5K	-
2220 (5750)	1.60±0.20	-	-	1K	-
	2.00±0.20	-	-	1K	-
	2.50±0.30	-	-	0.5K	-
	2.80±0.30	-	-	0.5K	-
	3.10±0.30	-	-	-	1K
2225 (5763)	1.60±0.20	-	-	1K	-
	2.00±0.20	-	-	1K	-
	2.50±0.30	-	-	0.5K	-
	2.80±0.30	-	-	0.5K	-

PACKAGE DIMENSION AND QUANTITY

- Embossed Tape Dimensions

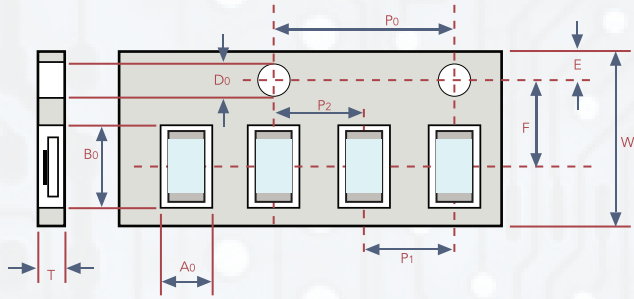

Dimension of paper tape

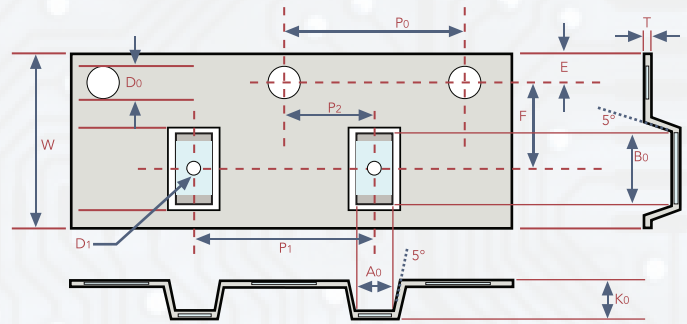

Dimension of plastic tape

SIZE	CHIP THICKNESS	A_0	B_0	T	K_0	W	P_0	$10X P_0$	P_1	P_2	D_0	D_1	E	F	UNIT
0402	0.50±0.05	0.70±0.20	1.20±0.20	≤0.80	-	8.00±0.10	4.00±0.10	40.00±0.10	2.00±0.05	2.00±0.05	1.55±0.05	-	1.75±0.05	3.50±0.05	MM
	0.50±0.10	0.70±0.20	1.20±0.20	≤0.80	-	8.00±0.10	4.00±0.10	40.00±0.10	2.00±0.05	2.00±0.05	1.55±0.05	-	1.75±0.05	3.50±0.05	MM
0603	0.80±0.07	1.00 +0.05/-0.1	1.80±0.10	0.95±0.05	-	8.00±0.10	4.00±0.10	40.00±0.20	4.00±0.10	2.00±0.05	1.55±0.05	-	1.75±0.05	3.50±0.05	MM
	0.80 +0.15/-0.1	1.02 +0.05/-0.1	1.80±0.10	0.97±0.05	-	8.00±0.10	4.00±0.10	40.00±0.20	4.00±0.10	2.00±0.05	1.55±0.05	-	1.75±0.05	3.50±0.05	MM
0805	0.80±0.10	1.50±0.10	2.30±0.10	0.95±0.05	-	8.00±0.10	4.00±0.10	40.00±0.20	4.00±0.10	2.00±0.05	1.55±0.05	-	1.75±0.05	3.50±0.05	MM
	1.25±0.10 1.25±0.20	<1.65	<2.40	0.23±0.05	<2.50	8.00±0.10	4.00±0.10	40.00±0.20	4.00±0.10	2.00±0.05	1.50 +0.10/-0	1.00±0.10	1.75±0.10	3.50±0.05	MM
1206	0.80±0.10	2.00±0.10	3.50±0.50	0.95±0.05	<2.50	8.00±0.10	4.00±0.10	40.00±0.20	4.00±0.10	2.00±0.05	1.55±0.05	-	1.75±0.10	3.50±0.05	MM
	0.95±0.10 1.25±0.10	<2.00	<3.70	0.23±0.05	<2.50	8.00±0.10	4.00±0.10	40.00±0.20	4.00±0.10	2.00±0.05	1.50 +0.10/-0	1.00±0.10	1.75±0.10	3.50±0.05	MM
	1.60±0.20 1.60±0.3/-0/1	<2.50	<4.00	0.23±0.05	<2.50	12.00±0.20	4.00±0.10	40.00±0.20	4.00±0.10	2.00±0.05	1.50±0.10/-0	1.50±0.10	1.75±0.10	5.50±0.05	MM
1210	1.25±0.10 1.60±0.20	<2.50	<4.00	0.23±0.05	<2.50	12.00±0.20	4.00±0.10	40.00±0.20	4.00±0.10	2.00±0.05	1.50±0.10/-0	1.50±0.10	1.75±0.10	5.50±0.05	MM
	2.50±0.30	<3.10	<4.00	0.23±0.05	<2.50	12.00±0.20	4.00±0.10	40.00±0.20	4.00±0.10	2.00±0.05	1.50 +0.10/-0	1.00±0.10	1.75±0.10	5.50±0.05	MM
1808	1.25±0.10 1.60±0.20	<2.50	<5.30	0.25±0.05	<2.50	12.00±0.20	4.00±0.10	40.00±0.20	4.00±0.10	2.00±0.05	1.50±0.10/-0	1.50±0.10	1.75±0.10	5.50±0.05	MM
	2.00±0.20	<2.50	<5.30	0.25±0.05	<2.50	12.00±0.20	4.00±0.10	40.00±0.20	4.00±0.10	2.00±0.05	1.50±0.10/-0	1.50±0.10	1.75±0.10	5.50±0.05	MM
1812	1.25±0.10 1.60±0.20 2.00±0.20	<3.90	<5.30	0.25±0.05	<2.50	12.00±0.20	4.00±0.10	40.00±0.20	8.00±0.10	2.00±0.05	1.50 +0.10/-0	1.50±0.10	1.75±0.10	5.50±0.05	MM
	2.50±0.30 2.80±0.30	<3.90	<5.30	0.25±0.05	<3.00	12.00±0.20	4.00±0.10	40.00±0.20	8.00±0.10	2.00±0.05	1.50 +0.10/-0	1.50±0.10	1.75±0.10	5.50±0.05	MM
1825	1.60±0.20 2.00±0.20	<6.80	<5.30	0.30±0.10	<2.50	12.00±0.20	4.00±0.10	40.00±0.20	8.00±0.10	2.00±0.05	1.50 +0.10/-0	1.50±0.10	1.75±0.10	5.50±0.05	MM
	2.50±0.30 2.80±0.30	<6.80	<5.30	0.30±0.10	<3.10	12.00±0.20	4.00±0.10	40.00±0.20	8.00±0.10	2.00±0.05	1.50 +0.10/-0	1.50±0.10	1.75±0.10	5.50±0.05	MM
2220	1.40±0.15 1.60±0.20 2.00±0.20	<5.80	<6.50	0.30±0.10	<2.50	12.00±0.20	4.00±0.10	40.00±0.20	8.00±0.10	2.00±0.05	1.50 +0.10/-0	1.50±0.10	1.75±0.10	5.50±0.05	MM
	2.50±0.30 2.80±0.30	<6.80	<6.50	0.30±0.10	<3.10	12.00±0.20	4.00±0.10	40.00±0.20	8.00±0.10	2.00±0.05	1.50 +0.10/-0	1.50±0.10	1.75±0.10	5.50±0.05	MM
	3.10±0.30	<5.60	<6.50	0.30±0.10	<4.20	12.00±0.20	4.00±0.10	40.00±0.20	8.00±0.10	2.00±0.05	1.50 +0.10/-0	1.50±0.10	1.75±0.10	5.50±0.05	MM
2224	1.60±0.20 2.00±0.20	<6.80	<6.50	0.30±0.10	<2.50	12.00±0.20	4.00±0.10	40.00±0.20	8.00±0.10	2.00±0.05	1.50 +0.10/-0	1.50±0.10	1.75±0.10	5.50±0.05	MM
	2.50±0.30 2.80±0.30	<6.80	<6.50	0.30±0.10	<3.10	12.00±0.20	4.00±0.10	40.00±0.20	8.00±0.10	2.00±0.05	1.50 +0.10/-0	1.50±0.10	1.75±0.10	5.50±0.05	MM



PACKAGE DIMENSION AND QUANTITY

- Reel Dimensions

SIZE	REEL SIZE	C	W ₁	W	A	N
0201, 0402, 0603, 0805, 1206, 1210, 0603	7"	13.0 + 0.5/-0.2	8.4 + 1.5	14.4max	178.0 ± 0.10	60.0 + 1.0/-0
	13"	13.0 + 0.7/-0.3	8.4 + 1.5	14.4max	330.0 ± 1.0	100 ± 1.0
1808, 1812, 1825, 2220, 2225	7"	13.0 + 0.5/-0.2	12.4 + 2.0/-0	18.4max	178.0 ± 0.10	60.0 + 1.0/-0
	13"	13.5 ± 0.5	12.4 + 2.0/-0	18.4max	330.0 ± 1.0	100 ± 1.0

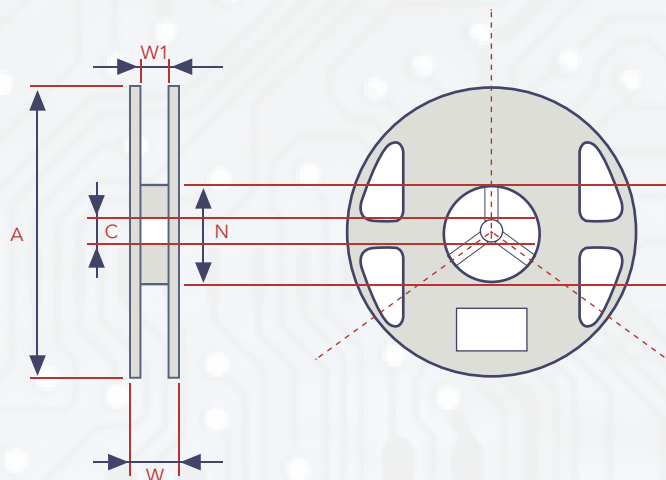

APPLICATION NOTES

STORAGE

- To prevent the damage of solderability of terminations, the following storage conditions are recommended:

- Indoors under 5 ~ 40°C and 20% ~ 70% RH.
- No harmful gases containing sulfuric acid, ammonia, hydrogen sulfide or chlorine.
- Packaging should not be opened until the capacitors are required for use. If opened, the pack should be re-sealed as soon as is practicable. Taped product should be stored out of direct sunlight, which might promote deterioration in tape or adhesion performance. The product is recommended to be used within 12 months after shipment and checked the solderability before use.

HANDLING

- Chip capacitors are dense, hard, brittle, and abrasive materials. They are liable to suffer mechanical damage, in the form of cracks or chips. Chip Capacitors should be handled with care to avoid contamination or damage. To use vacuum or plastic tweezers to pick up or plastic tweezers is recommended for manual placement. Tape and reeled packages are suitable for automatic pick and placement machine

PREHEAT

- In order to minimize the risk of thermal shock during soldering, a carefully controlled preheat is required. The rate of preheat should not exceed 3°C per second.

SOLDERING

- Use mildly activated rosin fluxes do not use activated flux. The amount of solder in each solder joint should be controlled to prevent the damage of chip capacitors caused by the stress between solder, chips, and substrate.

A) Hand Soldering:

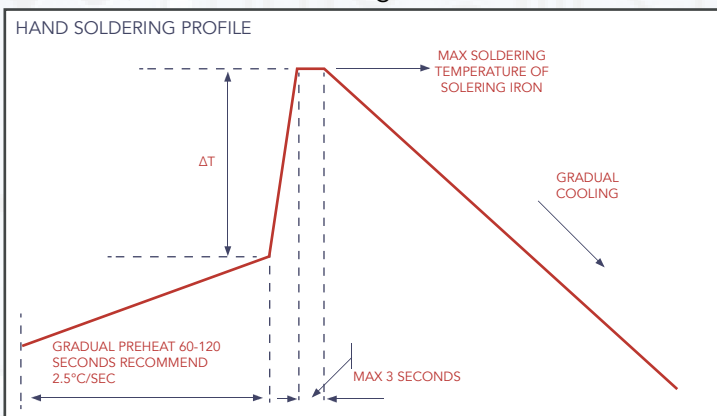

- Soldering iron tip diameter ≤1.0 mm and wattage max. 20W.
- The Capacitors shall be pre-heated and that the temperature gradient between the devices and the tip of the soldering iron.
- The required amount of solder shall be melted on the soldering tip.
- The tip of iron should not contact the ceramic body directly.
- The Capacitors shall be cooled gradually at room temperature after soldering.
- Forced air cooling is not allowed

CHIP SIZE	PRE-HEAT TEMP	ΔT	MAX SOLDERING IRON TEMP.
≤1206	≥150°C	≤150°C	≤350°C
1210 - 2225	≥150°C	≤130°C	≤280°C

APPLICATION NOTES

SOLDERING (cont.)

B) Reflow Soldering:

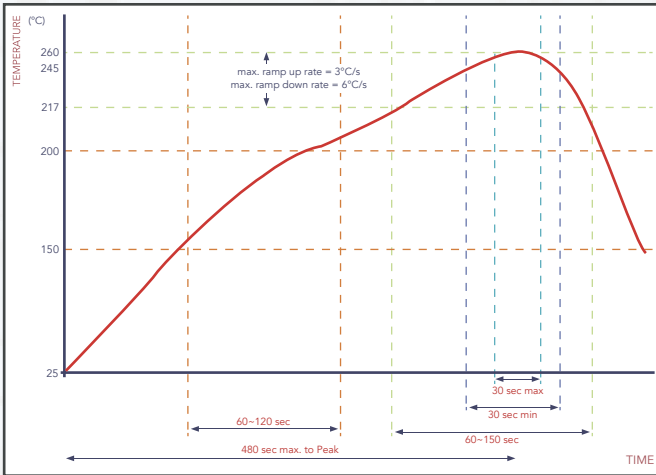

C) Wave Soldering:

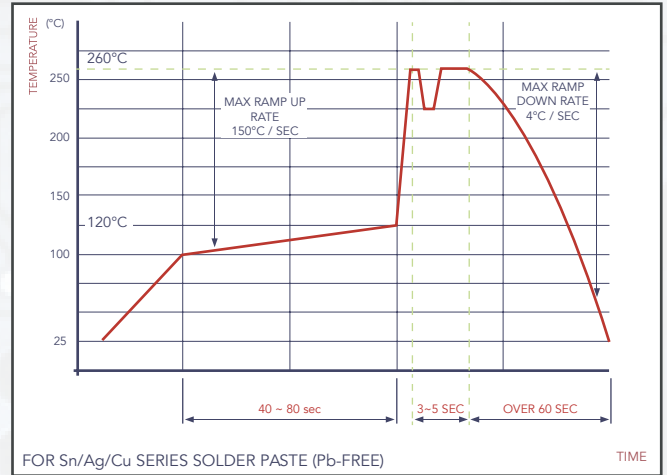

Soldering Conditions: Class I:

SIZE INCH (MM)	TEMPER. CHER.	CAPACITANCE	CONDITION	
			WAVE	REFLOW
≤0402 (1005)	Class I	ALL	X	O
0603 (1608)	Class I	ALL	O	O
0805 (2012)	Class I	ALL	O	O
1206 (3216)	Class I	ALL	O	O
		Thickness >0.95mm	X	O
≥1210 (3225)	Class I	ALL	X	O
Coating Products	ALL	ALL	X	O

SIZE INCH (MM)	TEMPER. CHER.	CAPACITANCE	CONDITION	
			WAVE	REFLOW
≤0402 (1005)	Class II	ALL	X	O
0603 (1608)	Class II	Cap. <2.2µF	O	O
		Cap. ≥2.2µF	X	O
0805 (2012)	Class II	Thickness ≤ 0.95mm	O	O
		Thickness > 0.95mm	X	O
1206 (3216)	Class II	Thickness ≤ 0.95mm	O	O
		Thickness >0.95mm	X	O
≥1210 (3225)	Class II	ALL	X	O
Coating Products	ALL	ALL	X	O

Soldering Height:

The solder climbing minimum height is suggesting to 25% of chip thickness or 500µm whichever is less. (Reference from IPC-610E)

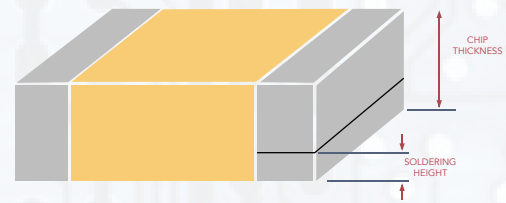

COOLING

- After soldering, cool the chips and the substrate gradually to room temperature. Natural cooling in air is recommended to minimize stress in the solder joint.

CLEANING

- All flux residues must be removed by using suitable electronic-grade vapor-cleaning solvents to eliminate contamination that could cause electrolytic surface corrosion. Good results can be obtained by using ultrasonic cleaning of the solvent. The choice of the proper system depends upon many factors such as component mix, flux, and solder paste and assembly method. The ability of the cleaning system to remove flux residues and contamination from under the chips is very important. Surface coating products are not suitable cleaning/washing by solvent



TYPICAL BENDING CRACKS OF MLCC

- MLCC ceramic body consists of rigid material. It will suffer compressive and tensional stress when the carried board is bended. If the suffered stress is over ceramic body strength, the bending crack is occurs. Therefore, the bending crack will occur after soldering process

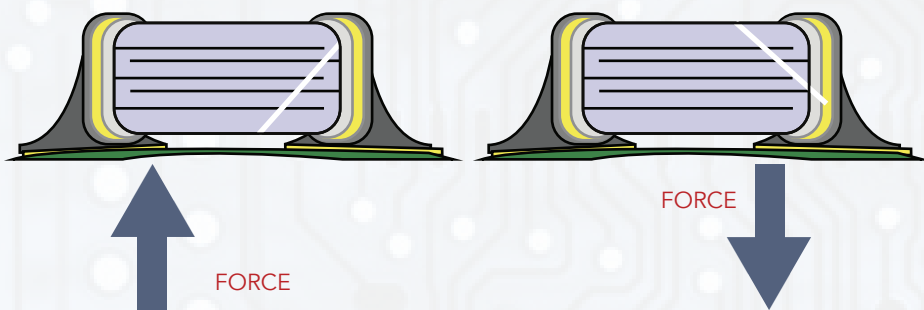

THE STRESS V.S. POSITION ON PCB DURING BENDING

- Chip mounting close to board separation point

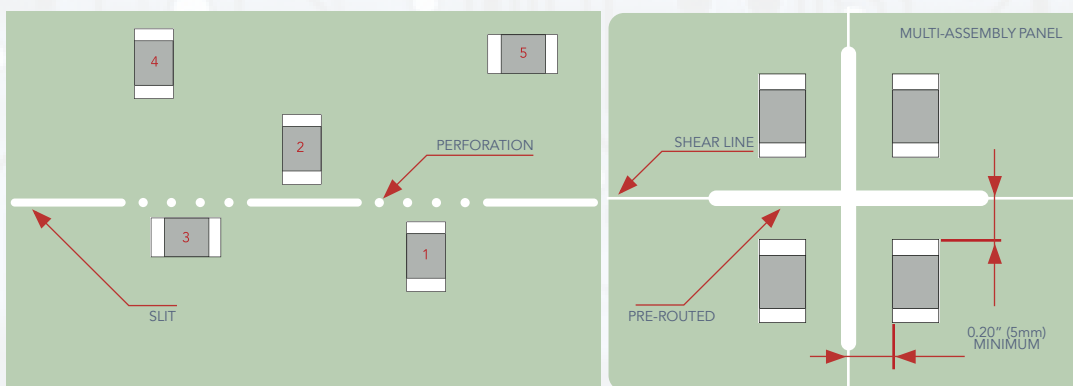

- Magnitude of stress $1 > 2 \approx 3 > 4 > 5$

STRUCTURE

- PDC soft termination series added a special termination material (Ultra-Buffer or Anti-Bend) between ceramic body and Ni-barrier that can absorb mechanical stress to prevent bending crack from occurring.

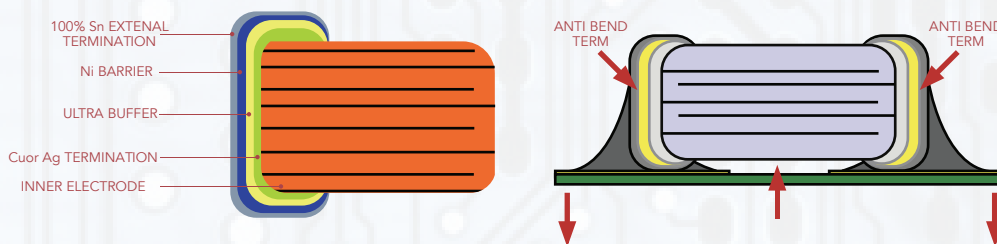
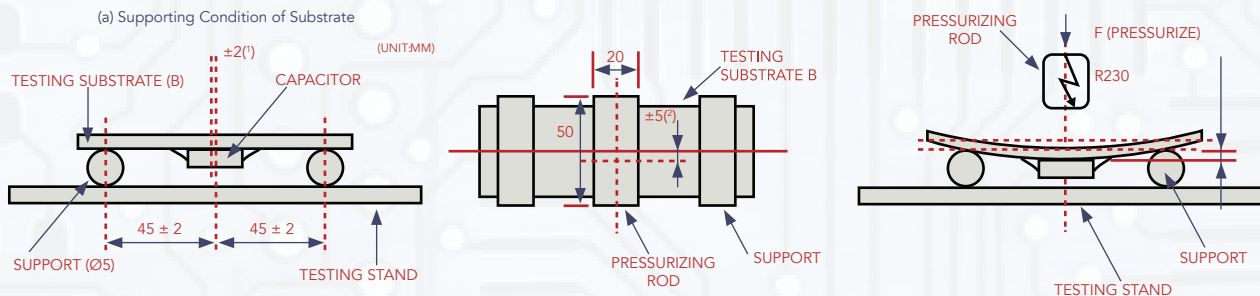

ILLUSTRATION OF BENDING TEST



Discrepancy between center of supports and center of substrate

Discrepancy between center of testing substrate A and center of pressurizing rod