

# MULTILAYER CERAMIC CAPACITORS

## - GUQ SERIES - ULTRA HIGH Q & LOW ESR SERIES -

### INTRODUCTION

- MLCC Consists of a conducting material and electrodes. To manufacture a chip-type SMT and achieve miniaturization, high density and high efficiency, ceramic condensers are used.
- Cal-Chip GUQ series MLCC is used at high frequencies and generally have a small temperature coefficient of capacitance, typical within the +/-30ppm/C required for NPO (COG) classification and have excellent conductivity internal electrode. Thus, Cal-Chip GUQ

### FEATURES

- High Q and low ESR performance at high frequency
- Ultra low capacitance to 0.1pF
- Can offer high precision tolerance to ±0.05pF
- Quality improvement of telephone calls for low power loss and better performance

### APPLICATIONS

- Telecommunication products & equipments: Mobile phone, WLAN, Base station
- RF module: Power amplifier, VCO
- Tuners

### CONSTRUCTION AND DIMENSIONS

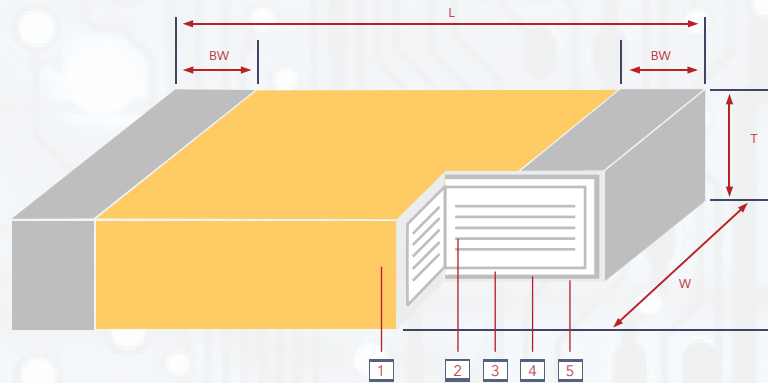

SIZE INCH (MM)	L (MM)	W (MM)	T (MM) / SYMBOL	REMARK	BW (MM)
1005 (0402)	0.40±0.02	0.20±0.02	0.20±0.02	V #	0.10±0.03
0201 (0603)	0.60±0.03	0.30±0.03	0.30±0.03	L #	0.10±0.03
0402 (1005)	1.00±0.05	0.50±0.05	0.50±0.05	N #	0.25±0.05/-0.10
	1.60±0.10	0.80±0.10	0.80±0.07	S	0.40±0.15
0603 (1608)	1.60±0.15/-0.10	0.80±0.15/-0.10	0.50±0.10	H	0.40±0.15
	2.00±0.15	1.25±0.10	0.60±0.10	A	0.50±0.20
0805 (2012)	1.40±0.38/-0.25	1.25±0.20	0.85±0.10	T	0.50±0.20
	1.40±0.38/-0.25	1.40±0.38	1.15±0.15	J #	0.25±0.25/-0.13
1111 (2828)	1.40±0.38/-0.25	2.79±0.38	≤1.78	G #	0.38±0.25

#Reflow soldering only is recommended

NO.	NAME	NPO
1	Ceramic Material	High Q Dielectric Ceramic
2	Inner Electrode	Cu
3	Termination	Inner Layer
	Middle Layer	Ni
	Outer Layer	Sn (Matt)

### ORDERING INFORMATION

GUQ	10	CG	101	J	250	N	T
SERIES	SIZE	DILECTRIC	CAPACITANCE	TOLERANCE	VOLTAGE	TERMINATION	PACKAGING
GUQ - Ultra High Q & Low ESR	02 - 0201 04 - 0402 10 - 0603 21 - 0805	CG - NPO / COG	Two significant digits followed b no. of zeros. An R is in place of decimal point eg.: 0R5: 0.5pF 1R0: 1.0pF 100: 10pF	A: ±0.05pF B: ± 0.1pF C: ± 0.25pF D: ± 0.5pF F: ± 1% G: ± 2% J: ± 5%	Two significant digits followed b no. of zeros. An R is in place of decimal point eg.: 25: 25 VDC 50: 50 VDC 100: 100 VDC 250: 250 VDC	N- Cu/Ni/Sn	T - 7" reel TD - 13 reel

## ELECTRICAL SPECIFICATIONS

DIALECTIC	NPO
SIZE	01005, 0201, 0402, 0505, 0603, 0805, 1111
CAPACITANCE RANGE	0.1pF to 1000pF
CAPACITANCE TOLERANCE	Cap<10pF: A (±0.05pF), B (±0.1pF), C (±0.25pF), D (±0.5pF) Cap≥10pF: F (±1%), G (±2%), J (±5%)
RATED VOLTAGE (WVDC)	6.3V, 10V, 25V, 50V, 100V, 200V 250V, 500V, 1500V
TAN δ	01005, 0201, 0402/25V~50V: Cap<30pF:Q≥400+20C; Cap≥30pF:Q≥1000 0402/100V~200V, 0603, 0805, 0505, 1111: Cap<30pF:Q≥800+20C; Cap≥30pF:Q≥1400
INSULATION RESISTANCE AT UR	≥10GΩ or RxC≥100Ω-F whichever is smaller
OPERATING TEMPERATURE	-55 TO +125°C
CAPACITANCE CHARACTERISTIC	±30ppm/ °C
TERMINATION	Ni/Sn (lead-free termination)

\* Measured at the condition of 25°C ambient temperature and 30~70% related humidity.  
Apply 1.0±0.2Vrms, 1.0MHz±10% for Cap≤1000pF and 1.0±0.2Vrms, 1.0kHz±10% for Cap>1000pF.

## ELECTRICAL SPECIFICATIONS

SIZE	THICKNESS (MM) / SYMBOL		PAPER TAPE	
			7" REEL	13" REEL
1005 (0402)	0.20±0.02	V	20k	
0201 (0603)	0.30±0.03	L	15k	70k
0402 (1005)	0.50±0.05	N	10k	50k
0505 (1414)	1.15±0.15	J	3k	
0603 (1608)	0.80±0.07	S	4k	
0603 (1608)	0.50±0.10	H	4k	
0805 (2012)	0.60±0.10	A	4k	15k
0805 (2012)	0.85±0.10	T	4k	15k
1111 (2828)	1.78	G	3k	





# CAPACITANCE RANGE

DIELECTRIC		NPO																				TOLERANCE
		1005		0201				0402				0505			0603			0805				
SIZE		16	25	6.3	10	25	50	25	50	100	200	50	100	250	50	100	250	50	100	250	500	
0.1pF	0R1			L	L	L	L	N	N	N	N				H	H	H					A, B
0.2pF	0R2	V	V	L	L	L	L	N	N	N	N				H	H	H	A	A	A	A	A, B
0.3pF	0R3	V	V	L	L	L	L	N	N	N	N				S	S	S	T	T	T	T	A, B
0.4pF	0R4	V	V	L	L	L	L	N	N	N	N	J	J	J	S	S	S	T	T	T	T	A, B
0.5pF	0R5	V	V	L	L	L	L	N	N	N	N	J	J	J	S	S	S	T	T	T	T	A, B, C
0.6pF	0R6	V	V	L	L	L	L	N	N	N	N	J	J	J	S	S	S	T	T	T	T	A, B, C
0.7pF	0R7	V	V	L	L	L	L	N	N	N	N	J	J	J	S	S	S	T	T	T	T	A, B, C
0.75pF	R75	V	V	L	L	L	L	N	N	N	N	J	J	J	S	S	S	T	T	T	T	A, B, C
0.8pF	0R8	V	V	L	L	L	L	N	N	N	N	J	J	J	S	S	S	T	T	T	T	A, B, C
0.9pF	0R9	V	V	L	L	L	L	N	N	N	N	J	J	J	S	S	S	T	T	T	T	A, B, C
1.0pF	1R0	V	V	L	L	L	L	N	N	N	N	J	J	J	S	S	S	T	T	T	T	A, B, C
1.1pF	1R1	V	V	L	L	L	L	N	N	N	N	J	J	J	S	S	S	T	T	T	T	A, B, C
1.2pF	1R2	V	V	L	L	L	L	N	N	N	N	J	J	J	S	S	S	T	T	T	T	A, B, C
1.3pF	1R3	V	V	L	L	L	L	N	N	N	N	J	J	J	S	S	S	T	T	T	T	A, B, C
1.4pF	1R4			L	L	L	L	N	N	N	N	J	J	J	S	S	S	T	T	T	T	A, B, C
1.5pF	1R5	V	V	L	L	L	L	N	N	N	N	J	J	J	S	S	S	T	T	T	T	A, B, C
1.6pF	1R6	V	V	L	L	L	L	N	N	N	N	J	J	J	S	S	S	T	T	T	T	A, B, C
1.7pF	1R7			L	L	L	L	N	N	N	N	J	J	J	S	S	S	T	T	T	T	A, B, C
1.8pF	1R8	V	V	L	L	L	L	N	N	N	N	J	J	J	S	S	S	T	T	T	T	A, B, C
1.9pF	1R9			L	L	L	L	N	N	N	N	J	J	J	S	S	S	T	T	T	T	A, B, C
2.0pF	2R0	V	V	L	L	L	L	N	N	N	N	J	J	J	S	S	S	T	T	T	T	A, B, C
2.1pF	2R1			L	L	L	L	N	N	N	N	J	J	J	S	S	S	T	T	T	T	A, B, C
2.2pF	2R2	V	V	L	L	L	L	N	N	N	N	J	J	J	S	S	S	T	T	T	T	A, B, C
2.3pF	2R3			L	L	L	L	N	N	N	N	J	J	J	S	S	S	T	T	T	T	A, B, C
2.4pF	2R4	V	V	L	L	L	L	N	N	N	N	J	J	J	S	S	S	T	T	T	T	A, B, C
2.5pF	2R5			L	L	L	L	N	N	N	N	J	J	J	S	S	S	T	T	T	T	A, B, C
2.6pF	2R6			L	L	L	L	N	N	N	N	J	J	J	S	S	S	T	T	T	T	A, B, C
2.7pF	2R7	V	V	L	L	L	L	N	N	N	N	J	J	J	S	S	S	T	T	T	T	A, B, C
2.8pF	2R8			L	L	L	L	N	N	N	N	J	J	J	S	S	S	T	T	T	T	A, B, C
2.9pF	2R9			L	L	L	L	N	N	N	N	J	J	J	S	S	S	T	T	T	T	A, B, C
3.0pF	3R0	V	V	L	L	L	L	N	N	N	N	J	J	J	S	S	S	T	T	T	T	A, B, C
3.1pF	3R1			L	L	L	L	N	N	N	N	J	J	J	S	S	S	T	T	T	T	A, B, C
3.2pF	3R2			L	L	L	L	N	N	N	N	J	J	J	S	S	S	T	T	T	T	A, B, C
3.3pF	3R3	V	V	L	L	L	L	N	N	N	N	J	J	J	S	S	S	T	T	T	T	A, B, C
3.4pF	3R4			L	L	L	L	N	N	N	N	J	J	J	S	S	S	T	T	T	T	A, B, C
3.5pF	3R5			L	L	L	L	N	N	N	N	J	J	J	S	S	S	T	T	T	T	A, B, C
3.6pF	3R6	V	V	L	L	L	L	N	N	N	N	J	J	J	S	S	S	T	T	T	T	A, B, C
3.7pF	3R7			L	L	L	L	N	N	N	N	J	J	J	S	S	S	T	T	T	T	A, B, C
3.8pF	3R8			L	L	L	L	N	N	N	N	J	J	J	S	S	S	T	T	T	T	A, B, C
3.9pF	3R9	V	V	L	L	L	L	N	N	N	N	J	J	J	S	S	S	T	T	T	T	A, B, C
4.0pF	4R0	V	V	L	L	L	L	N	N	N	N	J	J	J	S	S	S	T	T	T	T	A, B, C
4.1pF	4R1			L	L	L	L	N	N	N	N	J	J	J	S	S	S	T	T	T	T	A, B, C
4.2pF	4R2			L	L	L	L	N	N	N	N	J	J	J	S	S	S	T	T	T	T	A, B, C
4.3pF	4R3	V	V	L	L	L	L	N	N	N	N	J	J	J	S	S	S	T	T	T	T	A, B, C
4.4pF	4R4			L	L	L	L	N	N	N	N	J	J	J	S	S	S	T	T	T	T	A, B, C
4.5pF	4R5			L	L	L	L	N	N	N	N	J	J	J	S	S	S	T	T	T	T	A, B, C
4.6pF	4R6			L	L	L	L	N	N	N	N	J	J	J	S	S	S	T	T	T	T	A, B, C
4.7pF	4R7	V	V	L	L	L	L	N	N	N	N	J	J	J	S	S	S	T	T	T	T	A, B, C
4.8pF	4R8			L	L	L	L	N	N	N	N	J	J	J	S	S	S	T	T	T	T	A, B, C
4.9pF	4R9			L	L	L	L	N	N	N	N	J	J	J	S	S	S	T	T	T	T	A, B, C
5.0pF	5R0	V	V	L	L	L	L	N	N	N	N	J	J	J	S	S	S	T	T	T	T	A, B, C
5.1pF	5R1	V	V	L	L	L	L	N	N	N	N	J	J	J	S	S	S	T	T	T	T	A, B, C, D
5.2pF	5R2			L	L	L	L	N	N	N	N	J	J	J	S	S	S	T	T	T	T	A, B, C, D
5.3pF	5R3			L	L	L	L	N	N	N	N	J	J	J	S	S	S	T	T	T	T	A, B, C, D
5.4pF	5R4			L	L	L	L	N	N	N	N	J	J	J	S	S	S	T	T	T	T	A, B, C, D
5.5pF	5R5			L	L	L	L	N	N	N	N	J	J	J	S	S	S	T	T	T	T	A, B, C, D
5.6pF	5R6	V	V	L	L	L	L	N	N	N	N	J	J	J	S	S	S	T	T	T	T	A, B, C, D
5.7pF	5R7			L	L	L	L	N	N	N	N	J	J	J	S	S	S	T	T	T	T	A, B, C, D
5.8pF	5R8			L	L	L	L	N	N	N	N	J	J	J	S	S	S	T	T	T	T	A, B, C, D
5.9pF	5R9			L	L	L	L	N	N	N	N	J	J	J	S	S	S	T	T	T	T	A, B, C, D



# CAPACITANCE RANGE

DIELECTRIC		NPO																				TOLERANCE
SIZE	1005	0201				505			0402				0603			0805						
RATED VOLTAGE	16	25	6.3	10	25	50	50	100	250	25	50	100	200	50	100	250	50	100	250	500		
6.0pF	6R0	V	V	L	L	L	L	J	J	J	N	N	N	N	S	S	S	T	T	T	T	A, B, C, D
6.1pF	6R1			L	L	L	L	J	J	J	N	N	N	N	S	S	S	T	T	T	T	A, B, C, D
6.2pF	6R2	V		L	L	L	L	J	J	J	N	N	N	N	S	S	S	T	T	T	T	A, B, C, D
6.3pF	6R3			L	L	L	L	J	J	J	N	N	N	N	S	S	S	T	T	T	T	A, B, C, D
6.4pF	6R4			L	L	L	L	J	J	J	N	N	N	N	S	S	S	T	T	T	T	A, B, C, D
6.5pF	6R5			L	L	L	L	J	J	J	N	N	N	N	S	S	S	T	T	T	T	A, B, C, D
6.6pF	6R6			L	L	L	L	J	J	J	N	N	N	N	S	S	S	T	T	T	T	A, B, C, D
6.7pF	6R7	V		L	L	L	L	J	J	J	N	N	N	N	S	S	S	T	T	T	T	A, B, C, D
6.8pF	6R8	V		L	L	L	L	J	J	J	N	N	N	N	S	S	S	T	T	T	T	A, B, C, D
6.9pF	6R9			L	L	L	L	J	J	J	N	N	N	N	S	S	S	T	T	T	T	A, B, C, D
7.0pF	7R0	V		L	L	L	L	J	J	J	N	N	N	N	S	S	S	T	T	T	T	A, B, C, D
7.1pF	7R1			L	L	L	L	J	J	J	N	N	N	N	S	S	S	T	T	T	T	A, B, C, D
7.2pF	7R2			L	L	L	L	J	J	J	N	N	N	N	S	S	S	T	T	T	T	A, B, C, D
7.3pF	7R3			L	L	L	L	J	J	J	N	N	N	N	S	S	S	T	T	T	T	A, B, C, D
7.4pF	7R4			L	L	L	L	J	J	J	N	N	N	N	S	S	S	T	T	T	T	A, B, C, D
7.5pF	7R5	V		L	L	L	L	J	J	J	N	N	N	N	S	S	S	T	T	T	T	A, B, C, D
7.6pF	7R6			L	L	L	L	J	J	J	N	N	N	N	S	S	S	T	T	T	T	A, B, C, D
7.7pF	7R7			L	L	L	L	J	J	J	N	N	N	N	S	S	S	T	T	T	T	A, B, C, D
7.8pF	7R8			L	L	L	L	J	J	J	N	N	N	N	S	S	S	T	T	T	T	A, B, C, D
7.9pF	7R9			L	L	L	L	J	J	J	N	N	N	N	S	S	S	T	T	T	T	A, B, C, D
8.0pF	8R0	V		L	L	L	L	J	J	J	N	N	N	N	S	S	S	T	T	T	T	A, B, C, D
8.1pF	8R1			L	L	L	L	J	J	J	N	N	N	N	S	S	S	T	T	T	T	A, B, C, D
8.2pF	8R2	V		L	L	L	L	J	J	J	N	N	N	N	S	S	S	T	T	T	T	A, B, C, D
8.3pF	8R3			L	L	L	L	J	J	J	N	N	N	N	S	S	S	T	T	T	T	A, B, C, D
8.4pF	8R4			L	L	L	L	J	J	J	N	N	N	N	S	S	S	T	T	T	T	A, B, C, D
8.5pF	8R5			L	L	L	L	J	J	J	N	N	N	N	S	S	S	T	T	T	T	A, B, C, D
8.6pF	8R6			L	L	L	L	J	J	J	N	N	N	N	S	S	S	T	T	T	T	A, B, C, D
8.7pF	8R7			L	L	L	L	J	J	J	N	N	N	N	S	S	S	T	T	T	T	A, B, C, D
8.8pF	8R8			L	L	L	L	J	J	J	N	N	N	N	S	S	S	T	T	T	T	A, B, C, D
8.9pF	8R9			L	L	L	L	J	J	J	N	N	N	N	S	S	S	T	T	T	T	A, B, C, D
9.0pF	9R0	V		L	L	L	L	J	J	J	N	N	N	N	S	S	S	T	T	T	T	A, B, C, D
9.1pF	9R1	V		L	L	L	L	J	J	J	N	N	N	N	S	S	S	T	T	T	T	A, B, C, D
9.2pF	9R2			L	L	L	L	J	J	J	N	N	N	N	S	S	S	T	T	T	T	A, B, C, D
9.3pF	9R3			L	L	L	L	J	J	J	N	N	N	N	S	S	S	T	T	T	T	A, B, C, D
9.4pF	9R4			L	L	L	L	J	J	J	N	N	N	N	S	S	S	T	T	T	T	A, B, C, D
9.5pF	9R5			L	L	L	L	J	J	J	N	N	N	N	S	S	S	T	T	T	T	A, B, C, D
9.6pF	9R6			L	L	L	L	J	J	J	N	N	N	N	S	S	S	T	T	T	T	A, B, C, D
9.7pF	9R7			L	L	L	L	J	J	J	N	N	N	N	S	S	S	T	T	T	T	A, B, C, D
9.8pF	9R8			L	L	L	L	J	J	J	N	N	N	N	S	S	S	T	T	T	T	A, B, C, D
9.9pF	9R9			L	L	L	L	J	J	J	N	N	N	N	S	S	S	T	T	T	T	A, B, C, D
10pF	100	V	V	L	L	L	L	J	J	J	N	N	N	N	S	S	S	T	T	T	T	F, G, J
11pF	110			L	L	L	L	J	J	J	N	N	N	N	S	S	S	T	T	T	T	F, G, J
12pF	120	V	V	L	L	L	L	J	J	J	N	N	N	N	S	S	S	T	T	T	T	F, G, J
13pF	130			L	L	L	L	J	J	J	N	N	N	N	S	S	S	T	T	T	T	F, G, J
15pF	150	V	V	L	L	L	L	J	J	J	N	N	N	N	S	S	S	T	T	T	T	F, G, J
16pF	160			L	L	L	L	J	J	J	N	N	N	N	S	S	S	T	T	T	T	F, G, J
18pF	180			L	L	L	L	J	J	J	N	N	N	N	S	S	S	T	T	T	T	F, G, J
20pF	200	V	V	L	L	L	L	J	J	J	N	N	N	N	S	S	S	T	T	T	T	F, G, J
22pF	220	V	V	L	L	L		J	J	J	N	N	N	N	S	S	S	T	T	T	T	F, G, J
24pF	240			L	L	L		J	J	J	N	N	N	N	S	S	S	T	T	T	T	F, G, J
27pF	270			L	L	L		J	J	J	N	N	N	N	S	S	S	T	T	T	T	F, G, J
30pF	300			L	L	L		J	J	J	N	N	N	N	S	S	S	T	T	T	T	F, G, J
33pF	330			L	L	L		J	J	J	N	N	N	N	S	S	S	T	T	T	T	F, G, J
36pF	360							J	J	J	N	N	N	N	S	S	S	T	T	T	T	F, G, J
39pF	390							J	J	J	N	N	N	N	S	S	S	T	T	T	T	F, G, J
43pF	430							J	J	J	N	N	N	N	S	S	S	T	T	T	T	F, G, J
47pF	470							J	J	J	N	N	N	N	S	S	S	T	T	T	T	F, G, J
56pF	560							J	J	J	N	N	N	N	S	S	S	T	T	T	T	F, G, J
68pF	680							J	J	J	N	N	N	N	S	S	S	T	T	T	T	F, G, J
82pF	820							J	J	J	N	N	N	N	S	S	S	T	T	T	T	F, G, J
100pF	101							J	J	J	N	N	N	N	S	S	S	T	T	T	T	F, G, J
120pF	121																	T	T	T		F, G, J
150	151																	T	T	T		F, G, J
180	181																	T	T	T		F, G, J
220	221																	T	T	T		F, G, J





# CAPACITANCE RANGE

DIELECTRIC		NPO						TOLERANCE
SIZE		1111						
RATED VOLTAGE		50	100	200	250	500	1500	
1.0pF	1R0	G	G	G	G	G	G	A, B, C
1.1pF	1R1	G	G	G	G	G	G	A, B, C
1.2pF	1R2	G	G	G	G	G	G	A, B, C
1.3pF	1R3	G	G	G	G	G	G	A, B, C
1.5pF	1R5	G	G	G	G	G	G	A, B, C
1.6pF	1R6	G	G	G	G	G	G	A, B, C
1.8pF	1R8	G	G	G	G	G	G	A, B, C
2.0pF	2R0	G	G	G	G	G	G	A, B, C
2.2pF	2R2	G	G	G	G	G	G	A, B, C
2.4pF	2R4	G	G	G	G	G	G	A, B, C
2.7pF	2R7	G	G	G	G	G	G	A, B, C
3.0pF	3R0	G	G	G	G	G	G	A, B, C
3.3pF	3R3	G	G	G	G	G	G	A, B, C
3.6pF	3R6	G	G	G	G	G	G	A, B, C
3.9pF	3R9	G	G	G	G	G	G	A, B, C
4.0pF	4R0	G	G	G	G	G	G	A, B, C
4.3pF	4R3	G	G	G	G	G	G	A, B, C
5.0pF	5R0	G	G	G	G	G	G	A, B, C
5.1pF	5R1	G	G	G	G	G	G	B, C, D
5.6pF	5R6	G	G	G	G	G	G	B, C, D
6.0pF	6R0	G	G	G	G	G	G	B, C, D
6.1pF	6R1	G	G	G	G	G	G	B, C, D
6.8pF	6R8	G	G	G	G	G	G	B, C, D
7.0pF	7R0	G	G	G	G	G	G	B, C, D
8.0pF	8R0	G	G	G	G	G	G	B, C, D
8.2pF	8R2	G	G	G	G	G	G	B, C, D
10pF	100	G	G	G	G	G	G	F, G, J
12pF	120	G	G	G	G	G	G	F, G, J
15pF	150	G	G	G	G	G	G	F, G, J
18pF	180	G	G	G	G	G	G	F, G, J
22pF	220	G	G	G	G	G	G	F, G, J
27pF	270	G	G	G	G	G	G	F, G, J
33pF	330	G	G	G	G	G	G	F, G, J
39pF	390	G	G	G	G	G		F, G, J
47pF	470	G	G	G	G	G		F, G, J
56pF	560	G	G	G	G	G		F, G, J
68pF	680	G	G	G	G	G		F, G, J
82pF	820	G	G	G	G	G		F, G, J
100pF	101	G	G	G	G	G		F, G, J
120pF	121	G	G	G	G	G		F, G, J
150	151	G	G	G	G	G		F, G, J
180	181	G	G	G	G	G		F, G, J
220	221	G	G	G	G	G		F, G, J
220pF	221	G	G	G	G	G		F, G, J
270pF	271	G	G	G	G	G		F, G, J
330pF	331	G	G	G	G	G		F, G, J
390pF	391	G	G	G	G	G		F, G, J
470pF	471	G	G	G	G	G		F, G, J
560pF	561	G	G	G	G	G		F, G, J
680pF	681	G	G	G	G	G		F, G, J
820pF	821	G	G	G	G	G		F, G, J
1000pF	102	G	G	G	G	G		F, G, J

# ELECTRICAL CHARACTERISTICS

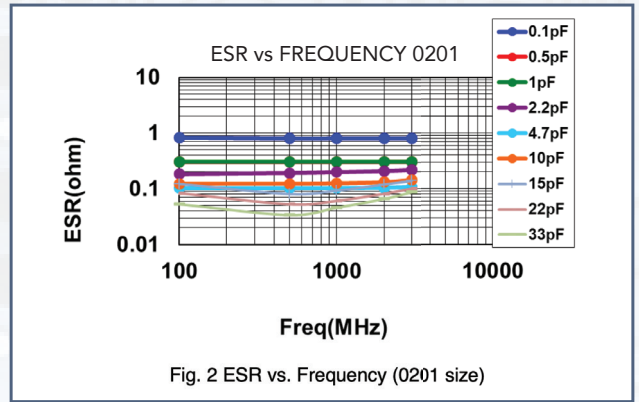
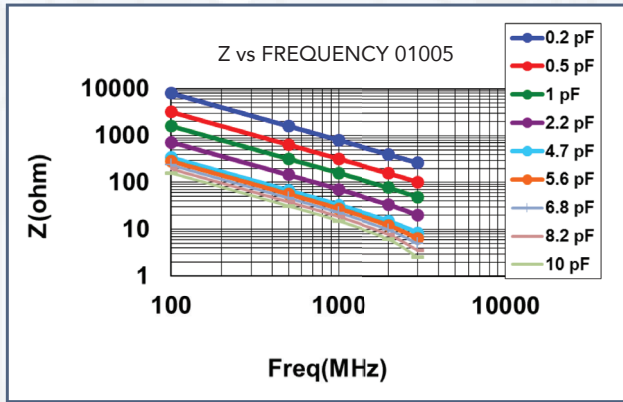
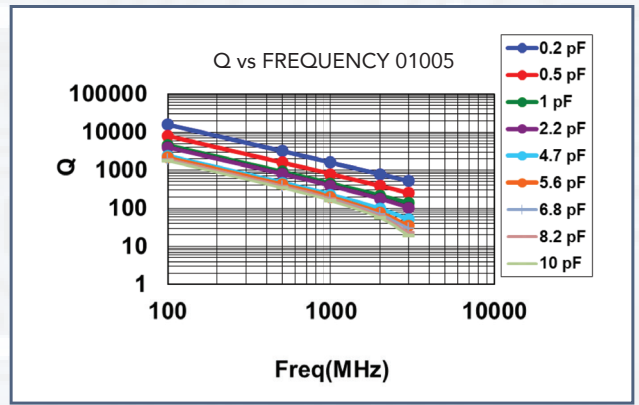
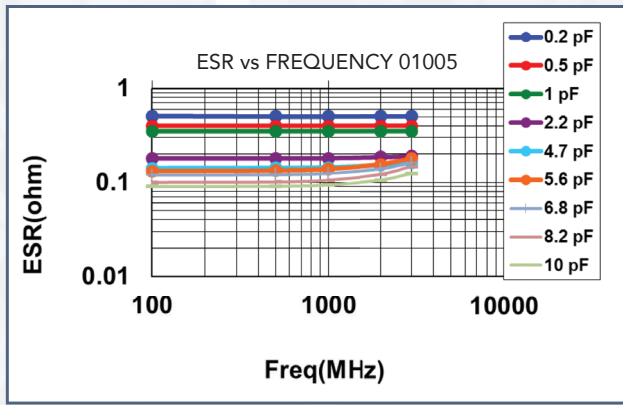
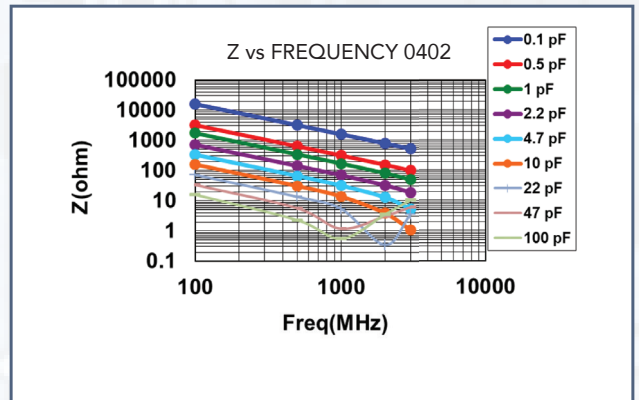
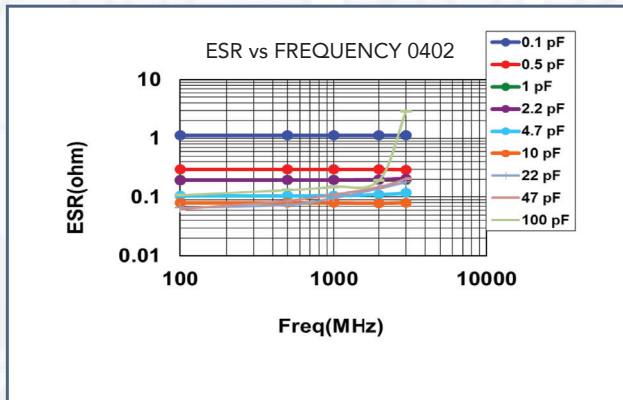
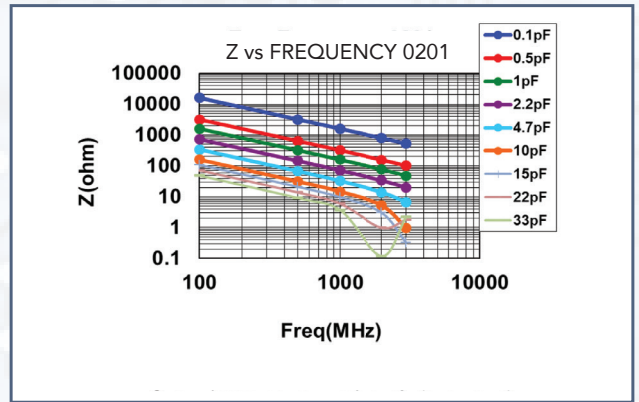
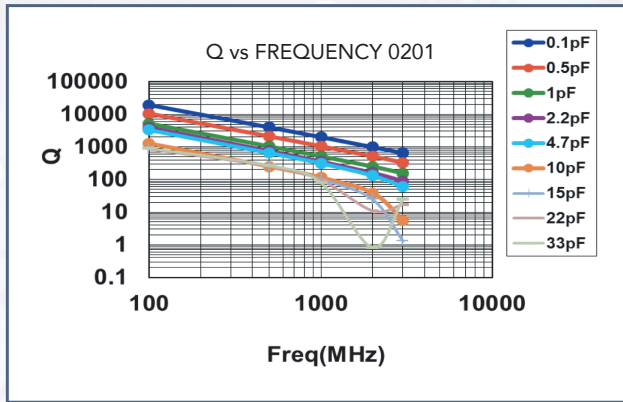
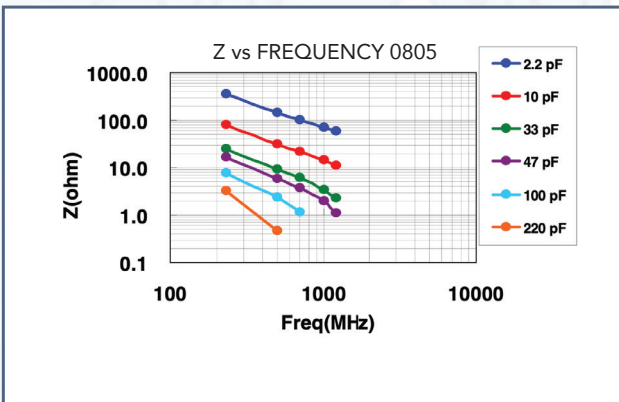
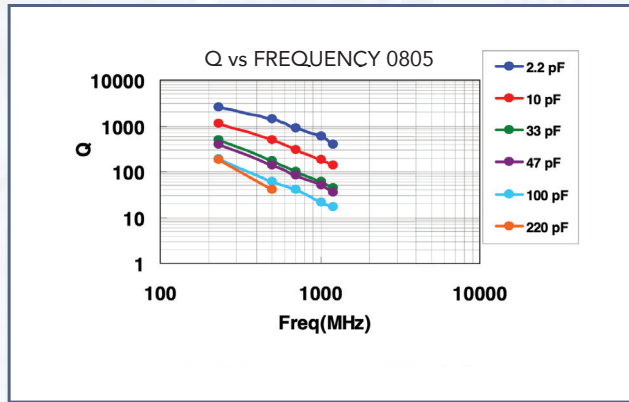
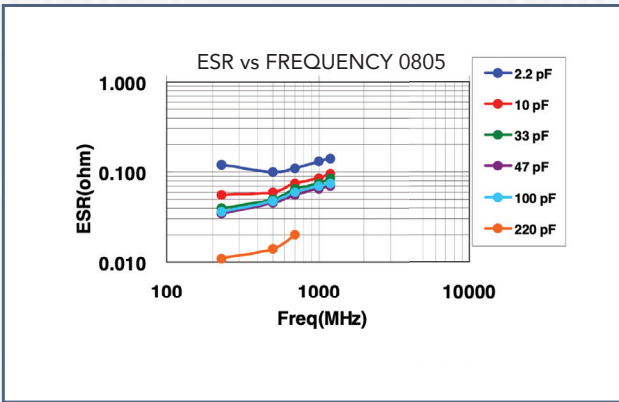
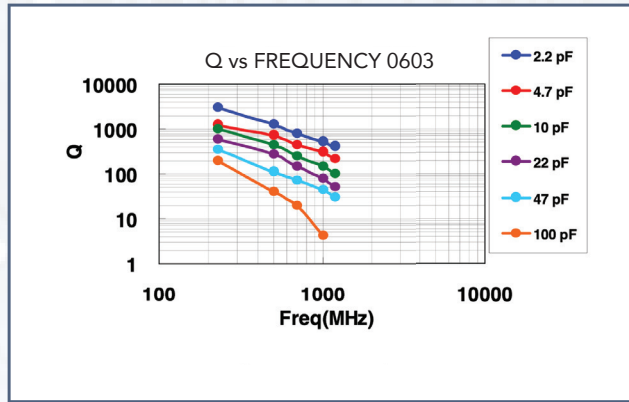
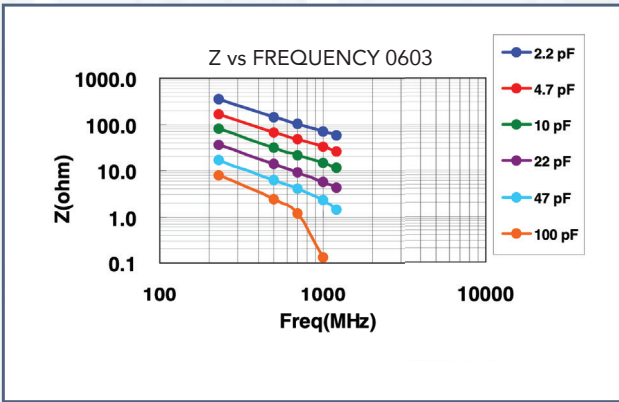
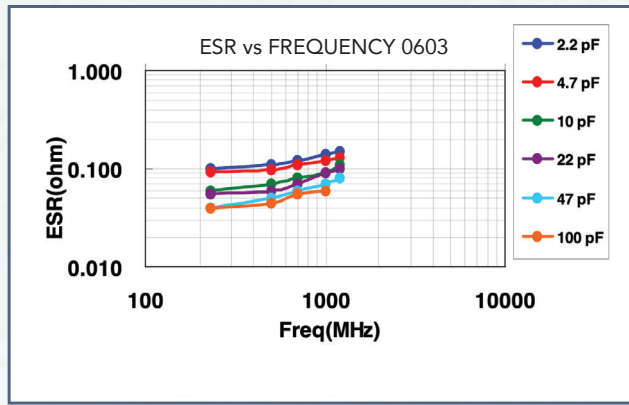
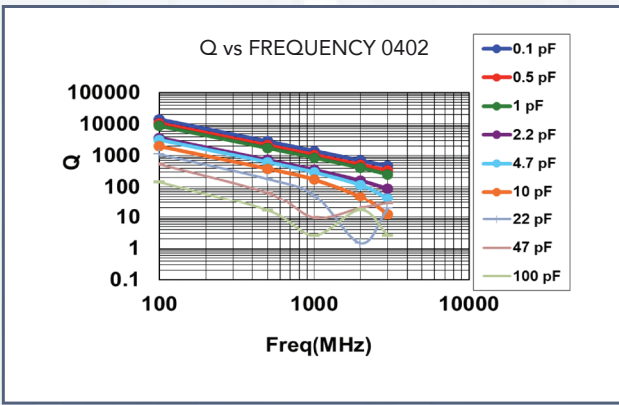

Fig. 2 ESR vs. Frequency (0201 size)





# ELECTRICAL CHARACTERISTICS



# ELECTRICAL CHARACTERISTICS

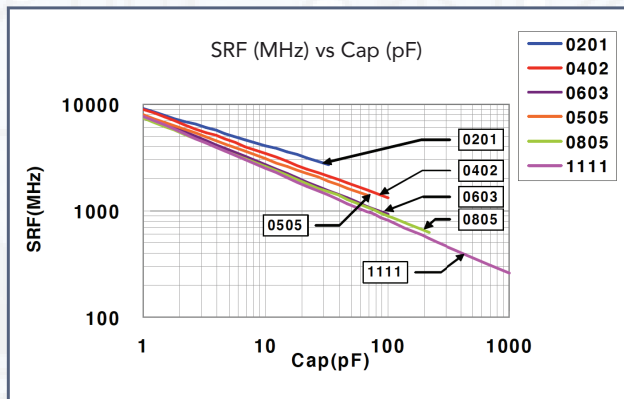
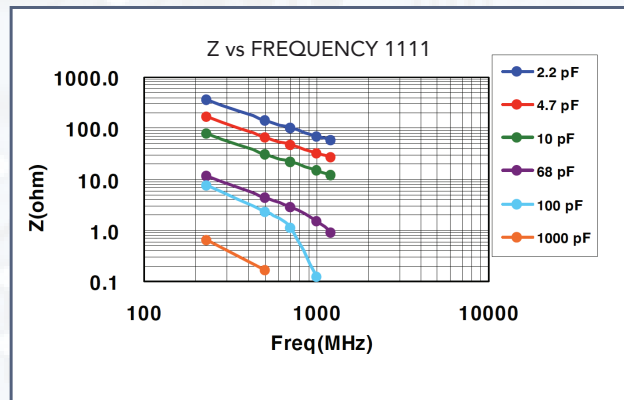
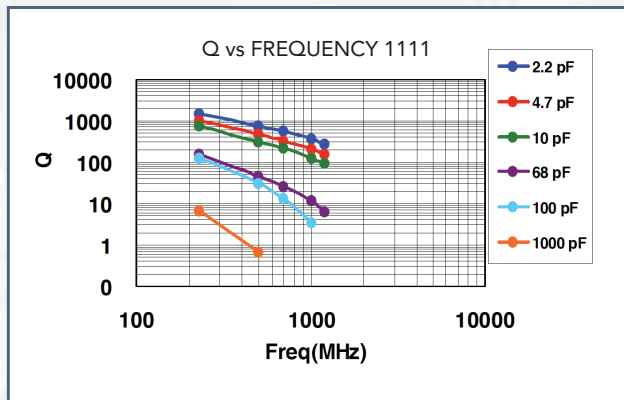
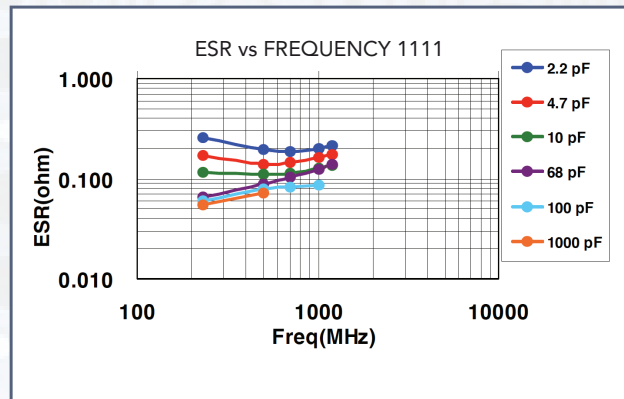
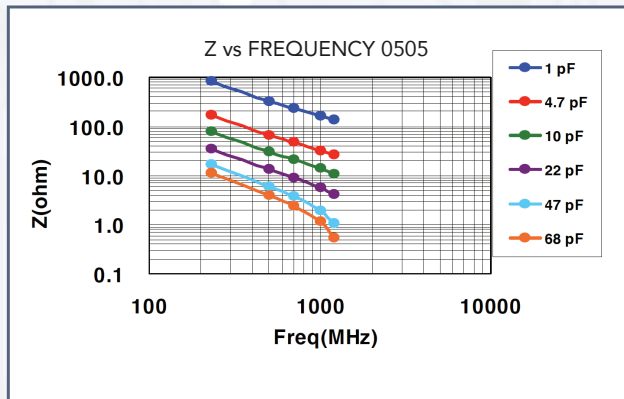
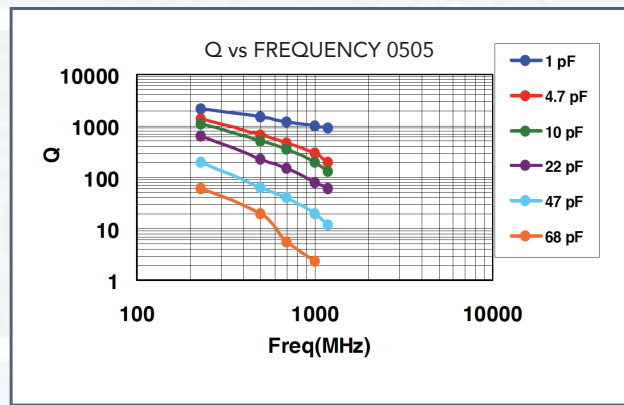
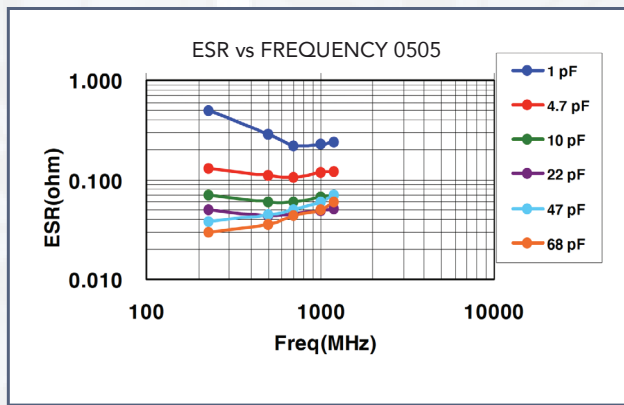



# RELIABILITY TEST CONDITIONS AND REQUIREMENTS

NO.	ITEM	TEST CONDITION	REQUIREMENTS															
1.	Visual and Mechanical	---	- No remarkable damage. - Dimensions to conform to individual specification sheet.															
2.	Capacitance		- Shall not exceed the limits given in the detailed spec.															
3.	Q/D.F (Dissipation Factor)	- 1.0±0.2Vrms, 1MHz±10% - Test temp.: Room Temperature.	- 01005, 0201, 0402/25V~50V: Cap<30pF: Q≥400+20C; Cap≥30pF, Q≥1000 - 0402/100V~200V, 0603, 0805, 0505, 1111: Cap<30pF: Q≥800+20C; Cap≥30pF:Q≥1400															
4.	Dielectric Strength	- To apply voltage: ≤100V : 250% of rated voltage. 200V ~ 300V : 200% of rated voltage. 500V ~ 999V : 150% of rated voltage. 1000V ~ 3000V : 120% of rated voltage. 4000V : 110% of rated voltage. - Duration: 1 to 5 sec. - Charge & discharge current less than 50mA.	-No evidence of damage or flash over during test.															
5.	Insulation Resistance	- Test temp.: Room Temperature. ≤100V : To apply rated voltage for max. 120 sec. ≥200V :To apply rated voltage (500V max.) for 60 sec.	- ≥10GΩ or RxC≥100Ω-F whichever is smaller															
6.	Temperature Coefficient	- With no electrical load. - Operating temperature: NPO: -55~125°C at 25°C	- Capacitance change: within ±30ppm/°C															
7.	Adhesive Strength of Termination	- Pressurizing force: 01005: 1N 0201: 2N 0402 to 0603: 5N >0603: 10N - Test time: 10±1 sec.	- No remarkable damage or removal of the terminations.															
8.	Vibration Resistance	- Vibration frequency: 10~55 Hz/min. - Total amplitude: 1.5mm - Test time: 6 hrs. (Two hrs each in three mutually perpendicular directions.) - Cap./DF(Q) Measurement to be made after de-aging at 150°C for 1hr then set for 24±2 hrs at room temp.	- No remarkable damage - Cap change and Q/D.F.: To meet initial spec															
9.	Solderability	- Solder temperature: 235±5°C - Dipping time: 2±0.5 sec.	- 95% min. coverage of all metalized area.															
10.	Bending Test	- The middle part of substrate shall be pressurized by means of the pressurizing rod at a rate of about 1 mm per second until the deflection becomes 1 mm and then the pressure shall be maintained for 5±1 sec. - Measurement to be made after keeping at room temp. for 24±2 hrs.	- No remarkable damage. - Cap change: within ±2.5% or ±0.25pF whichever is larger. - Q/D.F., I.R. and dielectric strength: To meet initial requirements. - 25% max. leaching on each edge.															
11.	Resistance to Soldering Heat	- Solder temperature: 260±5°C - Dipping time: 10±1 sec - Preheating: 120 to 150°C for 1 minute before immerse the capacitor in a eutectic solder. - Cap. / DF(Q) / I.R. Measurement to be made after de-aging at 150°C for 1hr then set for 24±2 hrs at room temp.	- No remarkable damage. - Cap change: within ±2.5% or ±0.25pF whichever is larger. - Q/D.F., I.R. and dielectric strength: To meet initial requirements. - 25% max. leaching on each edge.															
12.	Temperature Cycle	- Conduct the five cycles according to the temperatures and time. <table border="1" style="margin-left: 20px;"> <thead> <tr> <th>STEP</th> <th>TEMP. (°C)</th> <th>TIME (MIN)</th> </tr> </thead> <tbody> <tr> <td>1</td> <td>Min operating temp +0/-3</td> <td>30±3</td> </tr> <tr> <td>2</td> <td>Room temp</td> <td>2-3</td> </tr> <tr> <td>3</td> <td>Min operating temp +0/-3</td> <td>30±3</td> </tr> <tr> <td>4</td> <td>Room temp</td> <td>2-3</td> </tr> </tbody> </table> - Cap./DF (Q) / I.R. Measurement to be made after de-aging at 150°C for 1hr then set for 24±2 hrs at room temp.	STEP	TEMP. (°C)	TIME (MIN)	1	Min operating temp +0/-3	30±3	2	Room temp	2-3	3	Min operating temp +0/-3	30±3	4	Room temp	2-3	- No remarkable damage. - Cap change:within ±2.5% or ±0.25pF whichever is larger. - Q/D.F., I.R. and dielectric strength: To meet initial requirements.
STEP	TEMP. (°C)	TIME (MIN)																
1	Min operating temp +0/-3	30±3																
2	Room temp	2-3																
3	Min operating temp +0/-3	30±3																
4	Room temp	2-3																
13.	Humidity (Damp Heat) Steady State	Test temp.: 40±2°C - Humidity: 90~95% RH - Test time: 500+24/-0hrs. - Cap. / DF(Q) / I.R. Measurement to be made after de-aging at 150°C for 1hr then set for 24±2 hrs at room temp.	- No remarkable damage. - Cap change: within ±5.0% or ±0.5pF whichever is larger. - Q/D.F. value: Cap≥30pF, Q≥350; 10pF≤Cap<30pF, Q≥275+2.5C Cap<10pF; Q≥200+10C - I.R.: ≥1GΩ.															



## RELIABILITY TEST CONDITIONS AND REQUIREMENTS

NO.	ITEM	TEST CONDITION	REQUIREMENTS												
14.	Humidity (Damp Heat) Load	- Test temp.: 40±2°C - Humidity: 90~95%RH - Test time: 500+24/-0 hrs. - To apply voltage: rated voltage (MAX. 500V) - Cap. / DF(Q) / I.R. Measurement to be made after de-aging at 150°C for 1hr then set for 24±2 hrs at room temp	- No remarkable damage. - Cap change: within ±7.5% or ±0.75pF whichever is larger. - Q/D.F. value: Cap≥30pF, Q≥200; Cap<30pF, Q≥100+10/3C - I.R.: ≥500MΩ.												
15.	High Temperature Load (Endurance)	- Test temp.: NP0: 125±3°C - To apply voltage: (1) 10V≤Ur<500V: 200% of rated voltage. (2) ≤6.3V or 500V: 150% of rated voltage. (3) Ur≥630V: 120% of rated voltage. - Test time: 1000+24/-0 hrs. - Cap. / DF(Q) / I.R. Measurement to be made after de-aging at 150°C for 1hr then set for 24±2 hrs at room temp	- No remarkable damage. - Cap change: within ±3.0% or ±0.3pF whichever is larger. - Q/D.F. value: Cap≥30pF, Q≥350 10pF≤Cap<30pF, Q≥275+2.5C Cap<10pF, Q≥200+10C - I.R.: ≥1GΩ												
16.	ESR	- The ESR should be measured at room temperature and tested at frequency 1±0.1 GHz.  - The ESR should be measured at room temperature and tested at frequency 500±50 MHz	<table border="1"> <thead> <tr> <th>01005</th> <th>0505</th> <th>0603</th> </tr> </thead> <tbody> <tr> <td>0.2pF≤Caps1pF&lt; 700mΩ/pF 1pF&lt;Caps2pF&lt; 600mΩ 5pF&lt;Caps10pF&lt; 300mΩ 10pF&lt;Caps22pF&lt; 350mΩ 2pF&lt;Caps5pF&lt; 500mΩ</td> <td>0.4pF≤Cap&lt;1.0pF: &lt; 1500mΩ 1.0pF≤Cap&lt;10pF: &lt; 250mΩ 10pF≤Caps100pF: &lt; 200mΩ</td> <td>0.1pF≤Caps1pF&lt; 1500mΩ 1pF&lt;Caps10pF&lt; 250mΩ 10pF&lt;Caps220pF&lt; 200mΩ</td> </tr> <tr> <th>0201</th> <th>0402</th> <th>0805</th> </tr> <tr> <td>0.1pF≤Caps1pF&lt; 350mΩ/pF 1pF&lt;Caps5pF&lt; 300mΩ 5pF&lt;Caps22pF&lt; 250mΩ</td> <td>0.1pF≤Caps1pF&lt; 350mΩ/pF 1pF&lt;Caps5pF&lt; 300mΩ 5pF&lt;Caps100pF&lt; 250mΩ</td> <td>0.3pF≤Caps1pF: &lt; 1500mΩ 1pF&lt;Caps10pF: &lt; 250mΩ Cap&gt;10pF: &lt; 200mΩ</td> </tr> </tbody> </table>	01005	0505	0603	0.2pF≤Caps1pF< 700mΩ/pF 1pF<Caps2pF< 600mΩ 5pF<Caps10pF< 300mΩ 10pF<Caps22pF< 350mΩ 2pF<Caps5pF< 500mΩ	0.4pF≤Cap<1.0pF: < 1500mΩ 1.0pF≤Cap<10pF: < 250mΩ 10pF≤Caps100pF: < 200mΩ	0.1pF≤Caps1pF< 1500mΩ 1pF<Caps10pF< 250mΩ 10pF<Caps220pF< 200mΩ	0201	0402	0805	0.1pF≤Caps1pF< 350mΩ/pF 1pF<Caps5pF< 300mΩ 5pF<Caps22pF< 250mΩ	0.1pF≤Caps1pF< 350mΩ/pF 1pF<Caps5pF< 300mΩ 5pF<Caps100pF< 250mΩ	0.3pF≤Caps1pF: < 1500mΩ 1pF<Caps10pF: < 250mΩ Cap>10pF: < 200mΩ
			01005	0505	0603										
0.2pF≤Caps1pF< 700mΩ/pF 1pF<Caps2pF< 600mΩ 5pF<Caps10pF< 300mΩ 10pF<Caps22pF< 350mΩ 2pF<Caps5pF< 500mΩ	0.4pF≤Cap<1.0pF: < 1500mΩ 1.0pF≤Cap<10pF: < 250mΩ 10pF≤Caps100pF: < 200mΩ	0.1pF≤Caps1pF< 1500mΩ 1pF<Caps10pF< 250mΩ 10pF<Caps220pF< 200mΩ													
0201	0402	0805													
0.1pF≤Caps1pF< 350mΩ/pF 1pF<Caps5pF< 300mΩ 5pF<Caps22pF< 250mΩ	0.1pF≤Caps1pF< 350mΩ/pF 1pF<Caps5pF< 300mΩ 5pF<Caps100pF< 250mΩ	0.3pF≤Caps1pF: < 1500mΩ 1pF<Caps10pF: < 250mΩ Cap>10pF: < 200mΩ													
- 0201, 22pF≤Cap≤33pF: < 300mΩ - 1111, 100pF<Cap≤1000pF: < 150mΩ															



## TAPE & REEL DIMENSIONS

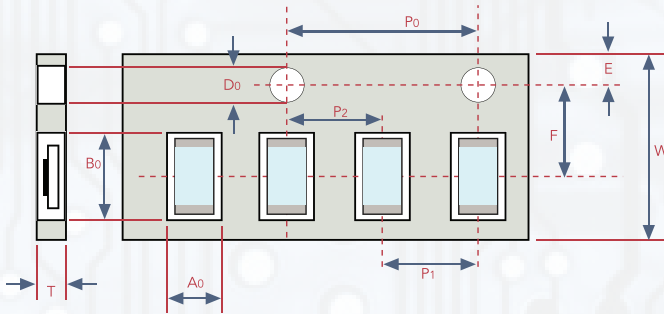

SIZE	01005, 0201, 0402, 0505, 0603, 0805, 1111	
REEL SIZE	7" REEL	13" REEL
C	13.0±0.5/-0.2	13.0±0.5/-0.2
W1	8.4±1.5/-0	8.4±1.5/-0
A	178.0±0.10	330.0±1.0
N	60.0±1.0/-0	100±1.0

SIZE	01005	0201	0402	0505	0603	0805	1111
THICKNESS	V	L	N	J	S	T	G
A <sub>0</sub>	13.0±0.5/-0.2	0.37±0.03	0.62±0.05	<1.90	1.00±0.05/-0.1	1.50±0.10	<3.05
B <sub>0</sub>	0.45±0.05	0.67±0.03	1.12±0.05	<1.90	1.80±0.10	2.30±0.10	<3.80
T	≤0.50	0.42±0.03	0.60±0.05	0.23±0.1	0.95±0.05	0.95±0.05	0.23±0.1
K <sub>0</sub>	-	-	-	<1.50	-	-	<2.50
W	8.00±0.30	8.00±0.10	8.00±0.10	8.00±0.30	8.00±0.10	8.00±0.10	8.00±0.30
P <sub>0</sub>	4.00±0.10	4.00±0.10	4.00±0.10	4.00±0.10	4.00±0.10	4.00±0.10	4.00±0.10
10 X P <sub>0</sub>	40.00±0.10	40.00±0.10	40.00±0.20	40.00±0.20	40.00±0.20	40.00±0.20	40.00±0.20
P <sub>1</sub>	2.00±0.05	2.00±0.05	2.00±0.05	4.00±0.10	4.00±0.10	4.00±0.10	4.00±0.10
P <sub>2</sub>	2.00±0.05	2.00±0.05	2.00±0.05	2.00±0.05	2.00±0.05	2.00±0.05	2.00±0.05
D <sub>0</sub>	1.50±0.1/-0	1.55±0.05	1.55±0.05	1.50±0.1/-0	1.55±0.05	1.55±0.05	1.50±0.1/-0
D <sub>1</sub>	-	-	-	1.00±0.10	-	-	1.00±0.10
E	1.75±0.10	1.75±0.05	1.75±0.05	1.75±0.10	1.75±0.05	1.75±0.05	1.75±0.10
F	3.50±0.05	3.50±0.05	3.50±0.05	3.50±0.05	3.50±0.05	3.50±0.05	3.50±0.05

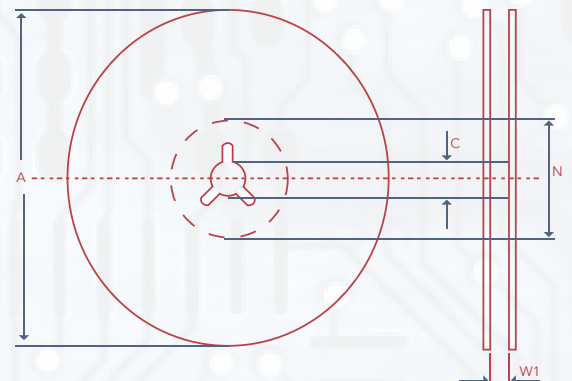

## STORAGE AND HANDLING CONDITIONS

- 1 - To store products at 5 to 40°C ambient temperature and 20 to 70% related humidity conditions
- 2 - The product is recommended to be used within one year after shipment. Check solderability in case of shelf life extension is needed

### Cautions:

- a. Don't store products in a corrosive environment such as sulfide, chloride gas, or acid. It may cause oxidization of electrode, which easily be resulted in poor soldering.
- b. To store products on the shelf and avoid exposure to moisture.
- c. Don't expose products to excessive shock, vibration, direct sunlight and so on.

## RECOMMENDED SOLDERING CONDITIONS

The lead-free termination MLCCs are not only to be used on SMT against lead-free solder paste, but also suitable against lead-containing solder paste. If the optimized solder joint is requested, increasing soldering time, temperature and concentration of N2 within oven are recommended.

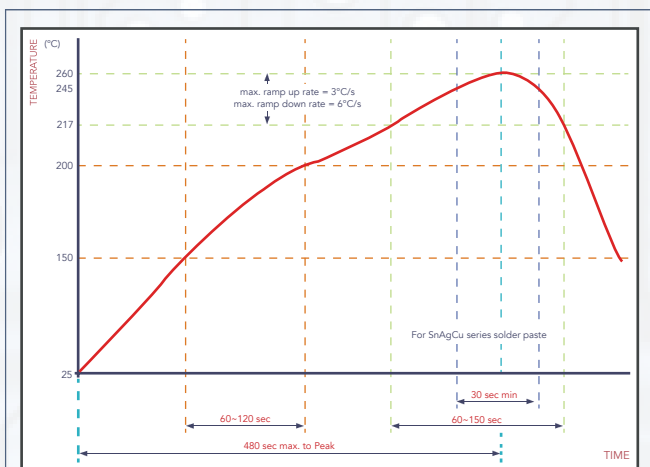

Recommended reflow soldering profile for SMT process with SnAgCu series paste.

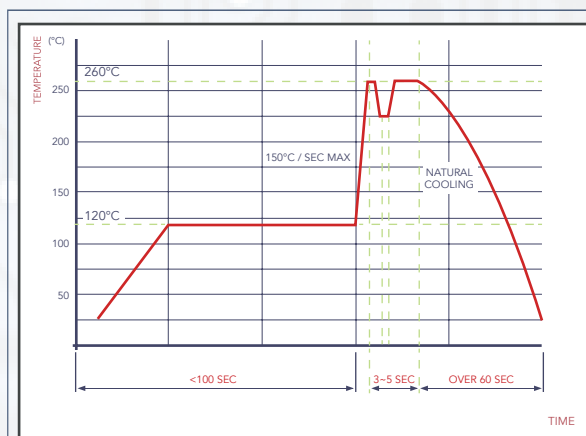

Recommended wave soldering profile for SMT process with SnAgCu series solder.