

PRODUCT IDENTIFICATION

- PRODUCT NAME Capacitor (MLCC)
- SERIES GMC10
- SIZE 0603
- DIALECTRIC C0G
- WEIGHT 4.7 (max)
- MANUFACTURE NAME Cal-Chip Electronics Inc.
- ADDRESS 59 Steamwhistle Drive Ivyland, PA 18974

GENERAL COMPOSITION

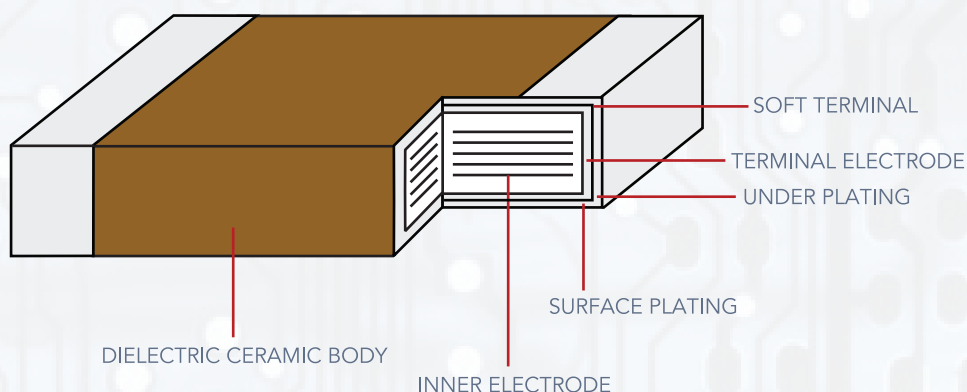

PART	MATERIAL		WEIGHT (mg)	% OF PART	% OF COMPONENT	CAS NO.
Body	Inner Electrode	Ni	0.38	8.44	8.17	7440-02-0
	Dielectric	BaTiO ₃	4.16	91.56	88.61	12047-27-7
SUBTOTAL			4.55	100	96.78	
Termination	Contact with Ceramic	Cu	0.109	72.03	2.32	7440-50-8
	Barrier Layer	Ni	0.021	14.21	0.46	7440-02-0
	Solder Plating	Sn	0.021	13.76	0.44	7440-31-5
SUBTOTAL			0.15	100	3.22	
ALL PARTS TOTAL			4.70		100	

MATERIAL DECLARATION

GMC10-X7R

PRODUCT IDENTIFICATION

- PRODUCT NAME	Capacitor (MLCC)
- SERIES	GMC10
- SIZE	0603
- DIALECTRIC	X7R
- WEIGHT	6.1 (max)
- MANUFACTURE NAME	Cal-Chip Electronics Inc.
- ADDRESS	59 Steamwhistle Drive Ivyland, PA 18974

GENERAL COMPOSITION

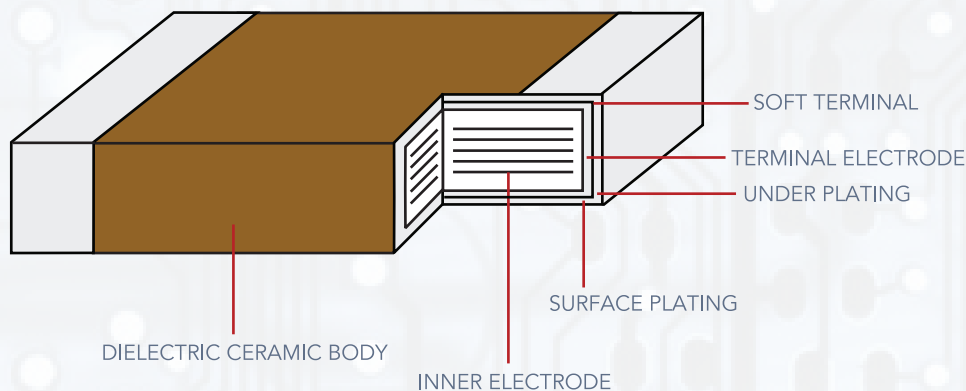

PART	MATERIAL		WEIGHT (mg)	% OF PART	% OF COMPONENT	CAS NO.
Body	Inner Electrode	Ni	1.51	25.34	24.71	7440-02-0
	Dielectric	BaTiO ₃	4.44	74.66	72.81	12047-27-7
SUBTOTAL			5.95	100	97.52	
Termination	Contact with Ceramic	Cu	0.109	72.03	1.78	7440-50-8
	Barrier Layer	Ni	0.021	14.21	0.35	7440-02-0
	Solder Plating	Sn	0.021	13.76	0.34	7440-31-5
SUBTOTAL			0.15	100	2.48	
ALL PARTS TOTAL			6.10		100	



PRODUCT IDENTIFICATION

- PRODUCT NAME Capacitor (MLCC)
- SERIES GMC10
- SIZE 0603
- DIALECTRIC X7S
- WEIGHT 6.1 (max)
- MANUFACTURE NAME Cal-Chip Electronics Inc.
- ADDRESS 59 Steamwhistle Drive Ivyland, PA 18974

GENERAL COMPOSITION

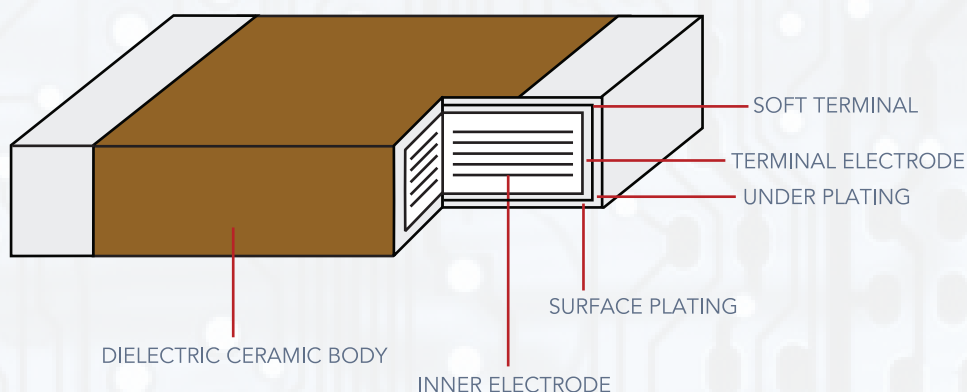

PART	MATERIAL		WEIGHT (mg)	% OF PART	% OF COMPONENT	CAS NO.
Body	Inner Electrode	Ni	1.51	25.34	24.71	7440-02-0
	Dielectric	BaTiO ₃	4.44	74.66	72.81	12047-27-7
SUBTOTAL			5.95	100	97.52	
Termination	Contact with Ceramic	Cu	0.109	72.03	1.78	7440-50-8
	Barrier Layer	Ni	0.021	14.21	0.35	7440-02-0
	Solder Plating	Sn	0.021	13.76	0.34	7440-31-5
SUBTOTAL			0.15	100	2.48	
ALL PARTS TOTAL			6.10		100	

PRODUCT IDENTIFICATION

- PRODUCT NAME	Capacitor (MLCC)
- SERIES	GMC10
- SIZE	0603
- DIALECTRIC	X6S
- WEIGHT	6.6 (max)
- MANUFACTURE NAME	Cal-Chip Electronics Inc.
- ADDRESS	59 Steamwhistle Drive Ivyland, PA 18974

GENERAL COMPOSITION

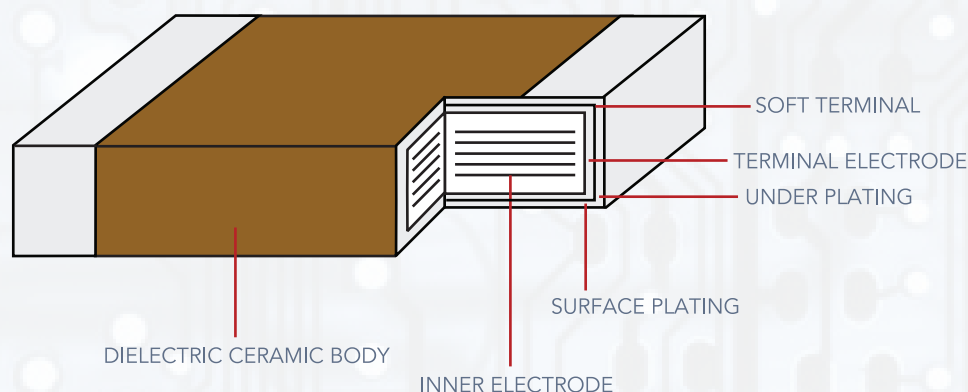

PART	MATERIAL		WEIGHT (mg)	% OF PART	% OF COMPONENT	CAS NO.
Body	Inner Electrode	Ni	1.30	20.10	19.64	7440-02-0
	Dielectric	BaTiO ₃	5.15	79.90	78.07	12047-27-7
SUBTOTAL			6.45	100	97.71	
Termination	Contact with Ceramic	Cu	0.109	72.03	1.65	7440-50-8
	Barrier Layer	Ni	0.021	14.21	0.33	7440-02-0
	Solder Plating	Sn	0.021	13.76	0.32	7440-31-5
SUBTOTAL			0.15	100	2.29	
ALL PARTS TOTAL			6.6		100	



PRODUCT IDENTIFICATION

- PRODUCT NAME Capacitor (MLCC)
- SERIES GMC10
- SIZE 0603
- DIALECTRIC X5R
- WEIGHT 6.6 (max)
- MANUFACTURE NAME Cal-Chip Electronics Inc.
- ADDRESS 59 Steamwhistle Drive Ivyland, PA 18974

GENERAL COMPOSITION

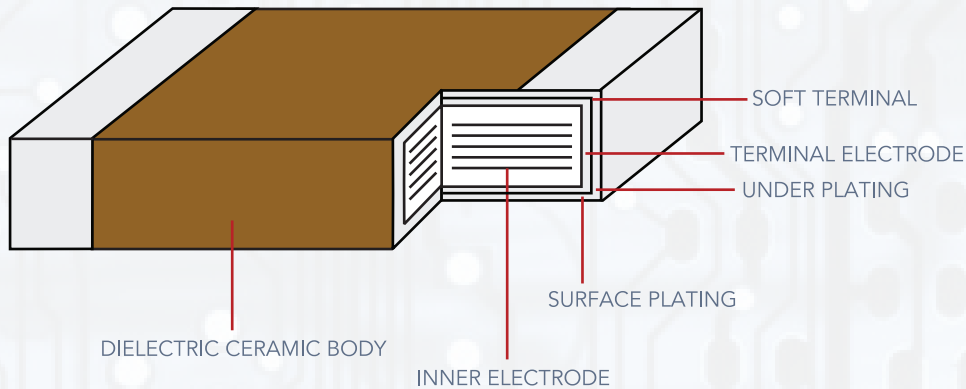

PART	MATERIAL		WEIGHT (mg)	% OF PART	% OF COMPONENT	CAS NO.
Body	Inner Electrode	Ni	1.30	20.10	19.64	7440-02-0
	Dielectric	BaTiO ₃	5.15	79.90	78.07	12047-27-7
SUBTOTAL			6.45	100	97.71	
Termination	Contact with Ceramic	Cu	0.109	72.03	1.65	7440-50-8
	Barrier Layer	Ni	0.021	14.21	0.33	7440-02-0
	Solder Plating	Sn	0.021	13.76	0.32	7440-31-5
SUBTOTAL			0.15	100	2.29	
ALL PARTS TOTAL			6.6		100	

MATERIAL DECLARATION

GMC10-Y5V

PRODUCT IDENTIFICATION

- PRODUCT NAME	Capacitor (MLCC)
- SERIES	GMC10
- SIZE	0603
- DIALECTRIC	Y5V
- WEIGHT	5.6 (max)
- MANUFACTURE NAME	Cal-Chip Electronics Inc.
- ADDRESS	59 Steamwhistle Drive Ivyland, PA 18974

GENERAL COMPOSITION

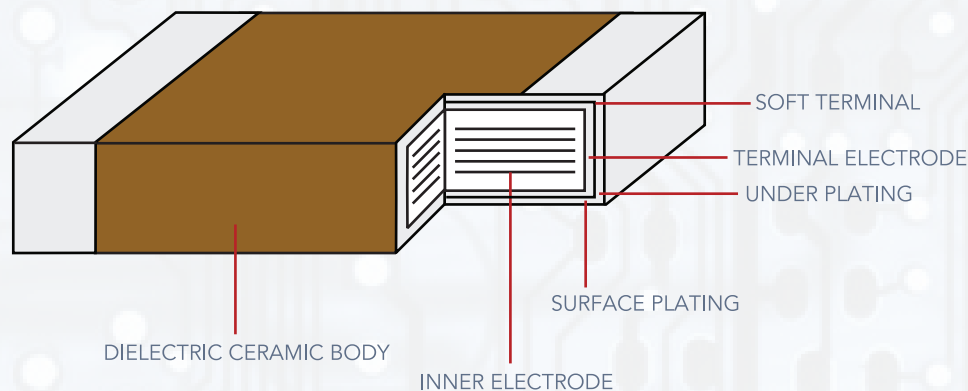

PART	MATERIAL		WEIGHT (mg)	% OF PART	% OF COMPONENT	CAS NO.
Body	Inner Electrode	Ni	0.10	17.43	16.96	7440-02-0
	Dielectric	BaTiO ₃	4.50	82.57	80.34	12047-27-7
SUBTOTAL			5.45	100	97.30	
Termination	Contact with Ceramic	Cu	0.109	72.03	1.94	7440-50-8
	Barrier Layer	Ni	0.021	14.21	0.38	7440-02-0
	Solder Plating	Sn	0.021	13.76	0.37	7440-31-5
SUBTOTAL			0.15	100	2.70	
ALL PARTS TOTAL			5.60		100	



PRODUCT IDENTIFICATION

- PRODUCT NAME Capacitor (MLCC)
- SERIES GMC10
- SIZE 0603
- DIALECTRIC Z5U
- WEIGHT 5.6 (max)
- MANUFACTURE NAME Cal-Chip Electronics Inc.
- ADDRESS 59 Steamwhistle Drive Ivyland, PA 18974

GENERAL COMPOSITION

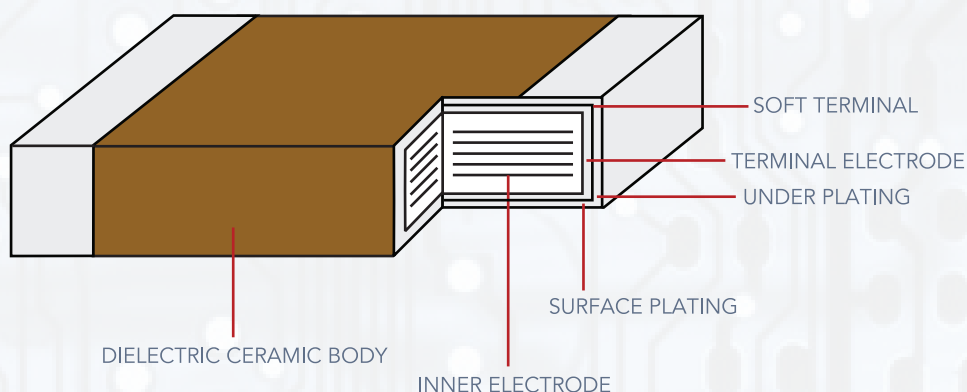

PART	MATERIAL		WEIGHT (mg)	% OF PART	% OF COMPONENT	CAS NO.
Body	Inner Electrode	Ni	0.10	17.43	16.96	7440-02-0
	Dielectric	BaTiO ₃	4.50	82.57	80.43	12047-27-7
SUBTOTAL			5.45	100	97.30	
Termination	Contact with Ceramic	Cu	0.109	72.03	1.94	7440-50-8
	Barrier Layer	Ni	0.021	14.21	0.38	7440-02-0
	Solder Plating	Sn	0.021	13.76	0.37	7440-31-5
SUBTOTAL			0.15	100	2.70	
ALL PARTS TOTAL			5.60		100	