

AUTOMOTIVE GRADE THIN FILM PRECISION CHIP RESISTOR

- CPR SERIES -

FEATURES

- AEC-Q200 Compliance
- Advanced thin film technology
- RoHS compliant
- Special materials, design, and processing for high sulfur application
- Test proven immunity to humidity, moisture and sulfur



APPLICATIONS

- Automotive
- Medical Equipment
- Testing / Measurement Equipment
- Printer Equipment
- Automatic Equipment Controller
- Converters
- Communication Device, Cell Phone, GPS, PDA

PART NUMBERING GUIDE

CPR	06	F	1002	CT5	25	
TYPE	DIMENSIONS	RESISTANCE TOLERANCE	RESISTANCE	PACKAGING CODE	TCR (PPM/°C)	POWER RATING
CPR SERIES	04: 0402 06: 0603 10: 0805 12: 1206 14: 1210 20: 2010 25: 2512	A: ±0.05% B: ±0.1% C: ±0.25% D: ±0.5% F: ±1%	10R2: 10.2Ω 1000: 100Ω 1001: 1KΩ 1002: 10KΩ 1003: 100KΩ 1004: 1MΩ	CT4: Embossed Plastic & 4K Reel CT5: Paper Tape & 5K Reel CT10: Paper Tape & 10K Reel	C: ±25 D: ±50	: Standard X : 1/10W W : 1/8W V : 1/4W O : 1/3W

CONSTRUCTION

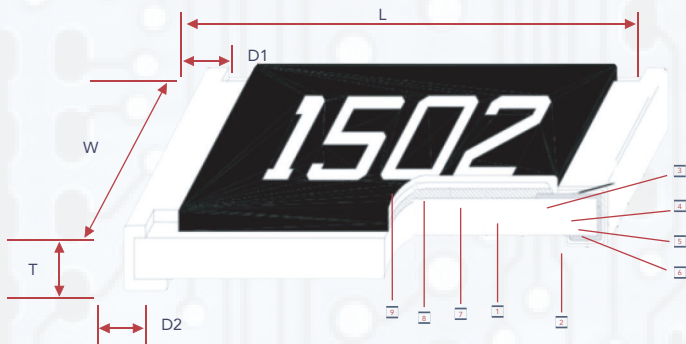

TYPE	SIZE (INCH)	L	W	T	D1	D2	WEIGHT (G) (1000PCS)
CPR04	0402	1.00 ± 0.05	0.50 ± 0.05	0.30 ± 0.05	0.20 ± 0.10	0.20 ± 0.10	0.54
CPR06	0603	1.55 ± 0.10	0.80 ± 0.10	0.45 ± 0.10		0.30 ± 0.20	1.83
CPR10	0805	2.00 ± 0.15	1.25 ± 0.15	0.55 ± 0.10	0.42 ± 0.20	0.40 ± 0.20	4.71
CPR12	1206	3.05 ± 0.15	1.55 ± 0.15			0.35 ± 0.25	9.02
CPR14	1210	3.10 ± 0.15	2.40 ± 0.15			0.55 ± 0.25	10
CPR20	2010	4.90 ± 0.15	2.40 ± 0.15	0.60 ± 0.30	0.50 ± 0.25	23.61	
CPR25	2512	6.30 ± 0.15	3.10 ± 0.15			38.06	

- | | | |
|-------------------------|---------------------------|------------------------------|
| 1 Alumina Substrate | 4 Edge Electrode (NiCr) | 7 Resistor Layer (Ag/Pd) |
| 2 Bottom Electrode (Ag) | 5 Barrier Layer (Ni) | 8 Primary Overcoat (Glass) |
| 3 Top Electrode (Ag-pd) | 6 External Electrode (Sn) | 9 Secondary Overcoat (Epoxy) |

DERATING CURVE

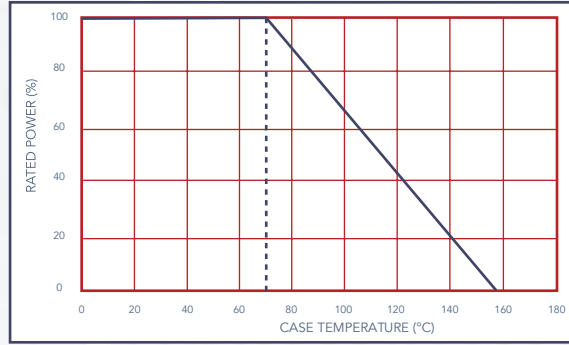

STANDARD ELECTRICAL SPECIFICATIONS

TYPE	POWER RATING AT 70°C	OPERATING TEMPERATURE	MAX OPERATING VOLTAGE	MAX OVERLOAD VOLTAGE	RESISTANCE RANGE					TCR (PPM/°C)
					±0.05%	±0.1%	±0.25%	±0.5%	±1%	
CPR04	1/16W	-55 ~ + 155°C	25V	50V	49.9Ω - 10KΩ	49.9Ω - 100KΩ				±25 ±50
CPR06	1/16W		50V	100V	10Ω - 49.9KΩ	10Ω - 332KΩ				
CPR10	1/10W		100V	200V	10Ω - 100KΩ	10Ω - 1MΩ				
CPR12	1/8W		10Ω - 200KΩ							
CPR14	1/4W		150V	300V	10Ω - 499KΩ					
CPR20										
CPR25	1/2W									

HIGH POWER RATING ELECTRICAL SPECIFICATIONS

TYPE	POWER RATING AT 70°C	OPERATING TEMPERATURE	MAX OPERATING VOLTAGE	MAX OVERLOAD VOLTAGE	RESISTANCE RANGE					TCR (PPM/°C)
					±0.05%	±0.1%	±0.25%	±0.5%	±1%	
CPR06	1/10W	-55 ~ + 155°C	75V	150V	10Ω - 49.9KΩ	10Ω - 332KΩ				±25 ±50
CPR10	1/8W		150V	300V	10Ω - 100KΩ	10Ω - 1MΩ				
CPR12	1/4W		10Ω - 200KΩ							
CPR14			200V	400V	10Ω - 499KΩ					
CPR20	1/3W									

Operating Voltage: $\sqrt{(P \cdot R)}$ or Max operating voltage listed above, whichever is lower
 Overload Voltage: $\sqrt{2.5 \cdot (P \cdot R)}$ or Max overload voltage listed above, whichever is lower

CalChip is capable of manufacturing the optional spec based on customer's requirement





ENVIRONMENTAL CHARACTERISTICS

ITEMS	REQUIREMENT		TEST METHODS
	TOL. $\leq 0.05\%$	TOL. $> 0.05\%$	
Temperature Coefficient	As Spec.		JIS-C-5201-1 4.8 IEC-60115-1 4.8 -55°C~+125°C, 25°C is the reference temperature
Short Term Overload	$\Delta R \pm 0.05\%$	$\Delta R \pm 0.2\%$	JIS-C-5201-1 4.13 IEC-60115-1 4.13 RCWV*2.5 or Max. overload voltage whichever is lower for 5 seconds
	$\Delta R \pm 0.2\%$ for high power rating		
Insulation Resistance	$>1000M\Omega$		JIS-C-5201-1 4.6 IEC-60115-1 4.6 Apply 100V _{DC} for 1 minute
Endurance	$\Delta R \pm 0.05\%$	$\Delta R \pm 0.2\%$	JIS-C-5201-1 4.25 IEC-60115-1 4.25.1 70 \pm 2°C, RCWV for 1000 hrs with 1.5 hrs "ON" and 0.5 hrs "OFF"
	$>7k\Omega \Delta R \pm 0.5\%$		
	$\Delta R \pm 0.5\%$ for high power rating		
Biased Humidity	$\Delta R \pm 0.05\%$	$\Delta R \pm 0.2\%$	MIL-STD-202 Method 103 1000 hrs 85°C/85% RH 10% of operating power.
	$>7k\Omega \Delta R \pm 0.5\%$		
	$\Delta R \pm 0.5\%$ for high power rating		
High Temperature Exposure	$\Delta R \pm 0.05\%$		MIL-STD-202 Method 108 at +155°C for 1000 hrs
Temperature Cycling	$\Delta R \pm 0.05\%$	$\Delta R \pm 0.2\%$	JESD22 Method JA-104 -55°C to +125°C, 1000 cycles
Bending Strength (Board Flex)	$\Delta R \pm 0.05\%$	$\Delta R \pm 0.2\%$	IEC-60115-14.33 JIS-C-5201-1 6.1.4 Bending amplitude 3 mm for 10 seconds
Solderability	95% min coverage		JIS-C-5201-1 4.17 IEC-60115-1 4.17 245 \pm 5°C for 3 seconds
Resistance to Soldering Heat	$\Delta R \pm 0.05\%$	$\Delta R \pm 0.2\%$	JIS-C-5201-1 4.18 IEC-60115-1 4.18 260 \pm 5°C for 10 seconds
Terminal Strength	No broken		AEC-Q200-002 FOrce of 1.8kg for 60 seconds
Mechanical Shock	$\Delta R \pm 0.25\%$	$\Delta R \pm 0.5\%$	MIL-STD-202 Method 213 Wave Form: Tolerance for half sine shock pulse. Peak value is 100g's. Normal duration (D) is 6
Vibration	$\Delta R \pm 0.25\%$	$\Delta R \pm 0.5\%$	MIL-STD-202 Method 204 5g's for 20 min., 12 cycles each of 3 orientations, 10-2000Hz
ESD	$\Delta R \pm 0.1\%$		AEC-Q200-002 Human Body, 2KV
Flame Retardance	Not Flame		AEC-Q200-001 Temperature sensing at 500°C, voltage power subjected to 32VDC current clamped up to 500ADC and decreased in 1.0VDC/hour.
Resistance to Solvents	Marking Unsmearred		MIL-STD-202 Mehod 215 Add Aqueous wash chemical - OKEM Clean or equivalnet. Do not use banned solvents
Sulfur Test	$\pm 0.5\%$		ASTM-B-809-95 3~5ppm H2S, 50 \pm 2°C, 91~93% R.H., no power rating for 1000 hrs

PACKAGING

- Reel Specifications & Packaging Quantity

TYPE	ØA	ØB	ØC	W	T	PAPER TAPE (EA)	EMBOSS PLASTIC TAPE (EA)
CPR04	178.0 ± 1.0	60.0 ± 1.0	13.5 ± 0.7	9.5 ± 1.0	11.5 ± 1.0	10,000	-
CPR06						-	
CPR10						-	
CPR12				-			
CPR14				-			
CPR20				13.5 ± 1.0	15.5 ± 1.0	-	4,000

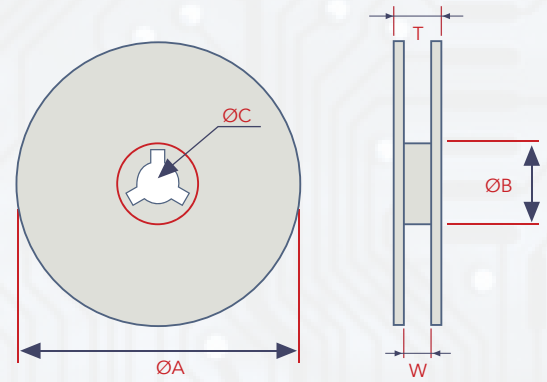

- Paper Tape Specifications

- Peel force of top cover tape
- The peel speed shall be about 300mm/min ±5%
- The peel force of top cover tape shall be between 8gf to 60 gf

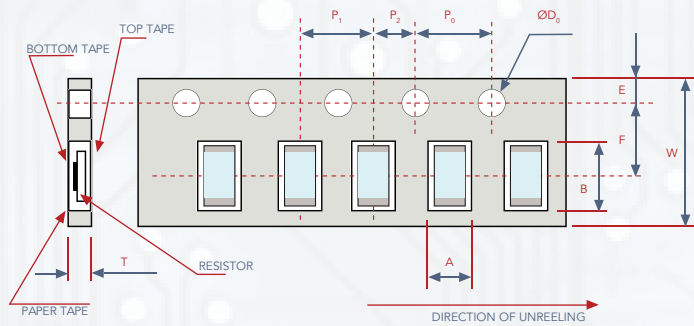

TYPE	A	B	W	E	F	P ₀	P ₁	P ₂	ØD ₀	T
CPR04	0.70±0.05	1.16±0.05	8.00±0.10	1.75±0.05	3.5±0.05	4.00±0.10	2.00±0.05	2.00±0.05	1.55±0.05	0.40±0.03
CPR06	1.10±0.05	1.90±0.05								0.60±0.03
CPR10	1.60±0.5	2.37±0.05								0.75±0.05
CPR12	2.00±0.05	3.55±0.05				4.00±0.10	1.60±0.10			
CPR14	2.75±0.05	3.40±0.05				4.00±0.05				

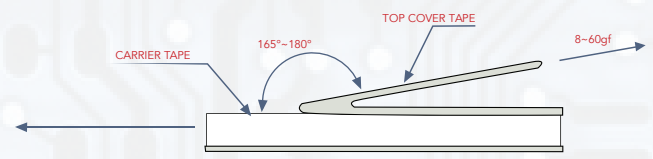

- Embossed Tape Specifications

- Peel force of top cover tape
- The peel speed shall be about 300mm/min ±5%
- The peel force of top cover tape shall be between 8gf to 60 gf

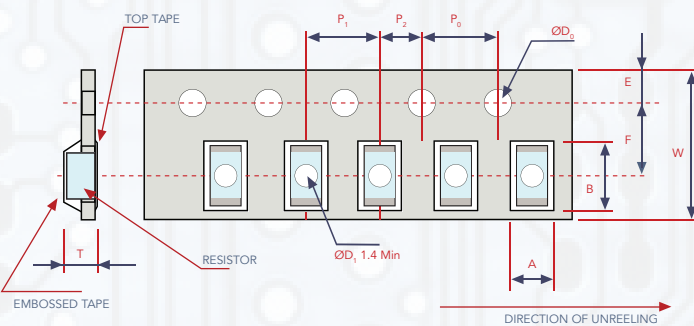

TYPE	A	B	W	E	F	P ₀	P ₁	P ₂	ØD ₀	T
CPR20	2.85±0.10	5.45±0.10	12.0±0.10	1.75±0.10	5.5±0.05	4.00±0.05	4.00±0.10	2.00±0.05	1.05±0.10	1.00±0.20
CPR25	3.40±0.10	6.65±0.10								

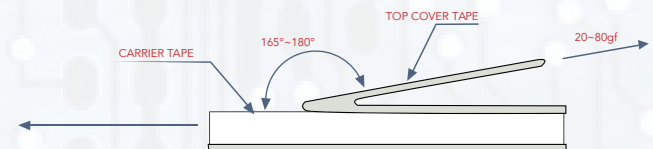

RECOMMENDED LAND PATTERN

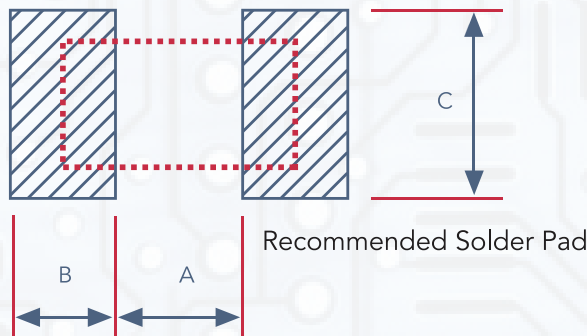

TYPE	A	B	C
CPR04	0.50	0.50	0.60±0.2
CPR06	0.80	1.00	0.90±0.2
CPR10	1.00	1.00	1.35±0.2
CPR12	2.00	1.15	1.70±0.2
CPR14	2.00	1.15	2.50±0.2
CPR20	3.60	1.40	2.50±0.2
CPR25	4.90	1.60	3.10±0.2



SOLDERING CONDITION

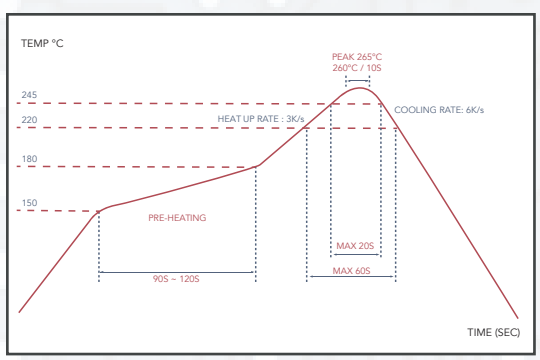

MARKING

- 0603: 3 Digit Marking
 3 Digit Marking for Example:
 14C = 13K7Ω
 13C = 13K3Ω

68B = 4K99Ω
 68X = 49.9Ω



- 0603: 3 Digit Marking for E24 Example: 101 = 100Ω | 102 = 1KΩ

E24 CODE	10	11	12	13	15	16	18	20	22	24	27	30	33	36	39	43	47	51	56	62	68	75	82	91
----------	----	----	----	----	----	----	----	----	----	----	----	----	----	----	----	----	----	----	----	----	----	----	----	----

CODE	E96	CODE	E96	CODE	E96	CODE	E96
01	100	25	178	49	316	73	563
02	102	26	182	50	324	74	576
03	105	27	187	51	330	75	590
04	107	28	191	52	340	76	604
05	110	29	196	53	348	77	619
06	113	30	200	54	357	78	634
07	115	31	205	55	365	79	649
08	118	32	210	56	374	80	665
09	121	33	215	57	383	81	681
10	124	34	221	58	392	82	698
11	127	35	226	59	402	83	715
12	130	36	232	60	412	84	732
13	133	37	237	61	422	85	750
14	137	38	243	62	432	86	758
15	140	39	249	63	442	87	787
16	143	40	255	64	453	88	806
17	147	41	261	65	464	89	825
18	150	42	267	66	475	90	845
19	154	43	274	67	487	91	866
20	158	44	280	68	499	92	887
21	162	45	287	69	511	93	909
22	165	46	294	70	523	94	931
23	169	47	301	71	536	95	952
24	174	48	309	72	549	96	976

CODE	A	B	C	D	E	F	G	H	X	Y	Z
MULTIPLIER	10 ⁰	10 ¹	10 ²	10 ³	10 ⁴	10 ⁵	10 ⁶	10 ⁷	10 ⁻¹	10 ⁻²	10 ⁻³



Cal-Chip
Electronics Inc.