

WIRE WOUND CHIP FERRITE INDUCTORS

- WF SERIES -

FEATURES

- Small Size For SMT
- Using Terminal Electrode Structure To Restrain The Parasitic Component Effect Quite Caused By Lead.
- Low DC Resistance , High Current And High Inductance.
- Excellent In Solder Ability And Heat Resistance

APPLICATIONS

RF PRODUCTS

- Wireless Communication Equipment And Various Types Of General Electronic Equipment
- Bluetooth Audio Circuit.
- Other Electronic Equipment.

PRODUCT STRUCTURE

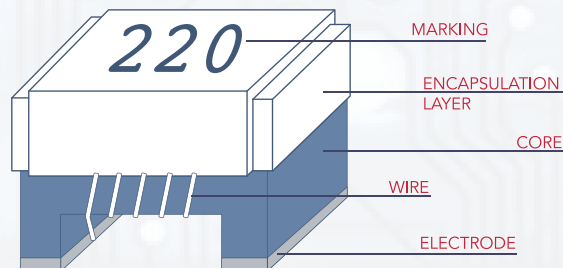

NO.	COMPONENT	MATERIAL
1	Core	Ni - Zn Ferrite
2	Electrode	Sn
3	Wire	Cu
4	Encapsulation Layer	UV Adhesive
6	Marking	UV Pringing Ink

*0603 series products are not marked

DIMENSION

TYPE	SIZE INCH	L (MAX)	W (MAX)	T (MAX)	A (TYP)	B (TYP)	C (TYP)	D (TYP)	E (TYP)
1608	0603	1.78 (0.070)	1.10 (0.043)	0.95 (0.037)	0.76 (0.030)	0.30 (0.012)	1.02 (0.040)	0.64 (0.025)	0.64 (0.025)
2012	0805	2.30 (0.091)	1.70 (0.067)	1.52 (0.060)	1.27 (0.050)	0.50 (0.020)	1.78 (0.070)	1.02 (0.040)	0.76 (0.030)
2520	1008	2.92 (0.115)	2.79 (0.110)	2.10 (0.083)	2.00 (0.079)	0.50 (0.020)	2.54 (0.100)	1.02 (0.040)	1.27 (0.050)
3225	1210	3.50 (0.138)	2.90 (0.114)	2.25 (0.088)	2.10 (0.083)	0.50 (0.020)	2.54 (0.100)	1.02 (0.040)	1.78 (0.070)
4532	1812	4.80 (0.189)	3.40 (0.134)	3.15 (0.124)	2.53 (0.100)	0.65 (0.026)	3.05 (0.120)	1.14 (0.045)	3.00 (0.118)

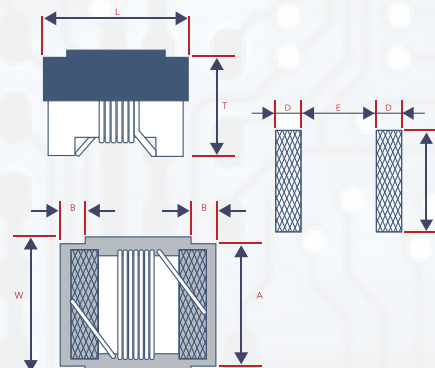

PART NUMBERING

WF	0805	T	R68	J
PRODUCT CODE	DIMENSIONS	PACKAGING	INDUCTANCE	TOLERANCE
WF Wire Wound Inductor Series	0603 - 1.6x0.8mm 0805 - 2.0x1.2mm 1008 - 2.5x2.0mm 1210 - 3.2x2.5mm 1812 - 4.5 x 3.2mm	Tape & Reel	010: 10nH R10: 100nH 1R0: 1.0µH 100: 10µH 101: 100µH 102: 1mH	J: ±5% K: ±10% M: ±20%

OPERATING TEMPERATURE RANGE

- WF SERIES - -40°C ~+85°C

ELECTRICAL CHARACTERISTICS

- Testing conditions

HP4286A or E4982A bridge or equivalent measuring instrument, test voltage 500mV.

Apply the rated current, and the surface temperature rise of the product shall not exceed 20°C.

Use a DC current source, LCR tester, and temperature gauge for testing.

0603 - TYPE

PART NUMBER	INDUCTANCE (μ H)	INDUCTANCE TOLERANCE	Q MIN.	SRF (MHZ) MIN	RDC (Ω) MAX	IDC (mA)
WF0603T047	0.047@7.9MHz	J,K	12@7.9MHz	1500	0.100	1000
WF0603T072	0.072@7.9MHz	J,K	12@7.9MHz	1400	0.120	1000
WF0603T082	0.082@7.9MHz	J,K	12@7.9MHz	1300	0.100	1000
WF0603TR10	0.10@7.9MHz	J,K	12@7.9MHz	1150	0.130	1000
WF0603TR12	0.12@7.9MHz	J,K	12@7.9MHz	1100	0.160	1000
WF0603TR15	0.15@7.9MHz	J,K	12@7.9MHz	1050	0.150	1000
WF0603TR18	0.18@7.9MHz	J,K	12@7.9MHz	950	0.180	1000
WF0603TR22	0.22@7.9MHz	J,K	12@7.9MHz	900	0.200	900
WF0603TR24	0.24@7.9MHz	J,K	12@7.9MHz	800	0.280	850
WF0603TR27	0.27@7.9MHz	J,K	12@7.9MHz	775	0.300	700
WF0603TR33	0.33@7.9MHz	J,K	12@7.9MHz	725	0.320	600
WF0603TR39	0.39@7.9MHz	J,K	12@7.9MHz	620	0.510	500
WF0603TR47	0.47@7.9MHz	J,K	12@7.9MHz	540	0.620	420
WF0603TR56	0.56@7.9MHz	J,K	12@7.9MHz	600	0.650	400
WF0603TR62	0.62@7.9MHz	J,K	12@7.9MHz	450	0.900	380
WF0603TR68	0.68@7.9MHz	J,K	12@7.9MHz	500	1.000	380
WF0603TR75	0.75@7.9MHz	J,K	12@7.9MHz	450	1.300	370
WF0603TR78	0.78@7.9MHz	J,K	12@7.9MHz	450	1.300	370
WF0603TR82	0.82@7.9MHz	J,K	12@7.9MHz	500	1.300	350
WF0603TR91	0.91@7.9MHz	J,K	12@7.9MHz	450	1.400	340
WF0603T1R0	1.0@7.9MHz	J,K	12@7.9MHz	400	1.500	330
WF0603T1R2	1.2@7.9MHz	J,K	12@7.9MHz	380	1.700	320
WF0603T1R5	1.5@7.9MHz	J,K	12@7.9MHz	300	1.900	310
WF0603T1R8	1.8@7.9MHz	J,K	12@7.9MHz	180	2.200	300
WF0603T2R0	2.0@7.9MHz	J,K	12@7.9MHz	180	2.300	280
WF0603T2R2	2.2@7.9MHz	J,K	12@7.9MHz	180	2.300	280
WF0603T2R7	2.7@7.9MHz	J,K	12@7.9MHz	150	3.100	250
WF0603T3R3	3.3@7.9MHz	J,K	12@7.9MHz	150	2.900	230
WF0603T3R9	3.9@7.9MHz	J,K	12@7.9MHz	120	3.200	210
WF0603T4R7	4.7@7.9MHz	J,K	12@7.9MHz	100	4.000	200
WF0603T6R8	6.8@7.9MHz	J,K	10@7.9MHz	28	3.9	200
WF0603T100	100@7.9MHz	J,K	10@7.9MHz	25	4.8	180
WF0603T150	150@7.9MHz	J,K	9@7.9MHz	18	8.5	150
WF0603T220	220@7.9MHz	J,K	9@7.9MHz	10	12	100





ELECTRICAL CHARACTERISTICS

0805 - TYPE

PART NUMBER	INDUCTANCE (μH)	INDUCTANCE TOLERANCE	Q MIN.	SRF (MHZ) MIN	RDC (Ω) MAX	IDC (mA)
WF0805TR12	0.12@25.2MHz	J,K	15@25.2MHz	1000	0.200	800
WF0805TR15	0.15@25.2MHz	J,K	15@25.2MHz	600	0.300	600
WF0805TR18	0.18@25.2MHz	J,K	15@25.2MHz	550	0.250	750
WF0805TR22	0.22@25.2MHz	J,K	15@25.2MHz	500	0.300	700
WF0805TR27	0.27@25.2MHz	J,K	15@25.2MHz	550	0.350	550
WF0805TR33	0.33@25.2MHz	J,K	15@25.2MHz	500	0.400	500
WF0805TR39	0.39@25.2MHz	J,K	12@25.2MHz	500	0.350	550
WF0805TR47	0.47@25.2MHz	J,K	10@25.2MHz	450	0.400	500
WF0805TR56	0.56@25.2MHz	J,K	10@25.2MHz	450	0.400	500
WF0805TR68	0.68@25.2MHz	J,K	10@25.2MHz	400	0.600	500
WF0805TR75	0.75@25.2MHz	J,K	10@25.2MHz	400	0.700	500
WF0805TR82	0.82@25.2MHz	J,K	10@25.2MHz	400	0.800	500
WF0805T1R0	1.0@7.96MHz	J,K	10@7.96MHz	360	1.000	430
WF0805T1R2	1.2@7.96MHz	J,K	10@7.96MHz	350	1.150	410
WF0805T1R5	1.5@7.96MHz	J,K	10@7.96MHz	300	1.200	400
WF0805T1R8	1.8@7.96MHz	J,K	10@7.96MHz	200	1.350	380
WF0805T2R2	2.2@7.96MHz	J,K	10@7.96MHz	170	1.500	350
WF0805T2R7	2.7@7.96MHz	J,K	10@7.96MHz	100	1.700	320
WF0805T3R3	3.3@7.96MHz	J,K	10@7.96MHz	90	1.800	300
WF0805T3R9	3.9@7.96MHz	J,K	10@7.96MHz	90	1.950	280
WF0805T4R7	4.7@7.96MHz	J,K	10@7.96MHz	85	2.050	250
WF0805T5R6	5.6@7.96MHz	J,K	10@7.96MHz	70	2.300	240
WF0805T6R8	6.8@7.96MHz	J,K	10@7.96MHz	55	2.600	220
WF0805T7R5	7.5@7.96MHz	J,K	10@7.96MHz	55	2.800	210
WF0805T8R2	8.2@7.96MHz	J,K	10@7.96MHz	50	3.000	180
WF0805T100	10@2.52MHz	J,K	8@2.52MHz	30	3.200	150
WF0805T120	12@2.52MHz	J,K	8@2.52MHz	17	3.500	110
WF0805T150	15@2.52MHz	J,K	8@2.52MHz	16	4.200	100
WF0805T180	18@2.52MHz	J,K	8@2.52MHz	15	4.500	95
WF0805T220	22@2.52MHz	J,K	8@2.52MHz	14	6.000	80



ELECTRICAL CHARACTERISTICS

1008 - TYPE

PART NUMBER	INDUCTANCE (μ H)	INDUCTANCE TOLERANCE	Q MIN.	SRF (MHZ) MIN	RDC (Ω) MAX	IDC (mA)
WF1008TR12__	0.12@25.2MHz	J,K	12@25.2MHz	850	0.15	800
WF1008TR39__	0.39@25.2MHz	J,K	12@25.2MHz	480	0.29	600
WF1008TR47__	0.47@25.2MHz	J,K	20@25.2MHz	380	0.30	600
WF1008TR56__	0.56@25.2MHz	J,K	12@25.2MHz	330	0.42	600
WF1008TR68__	0.68@25.2MHz	J,K	12@25.2MHz	330	0.45	600
WF1008TR82__	0.82@25.2MHz	J,K	12@25.2MHz	300	0.62	600
WF1008T1R0__	1.0@25.2MHz	J,K	12@25.2MHz	300	0.55	580
WF1008T1R2__	1.2@7.96MHz	J,K	12@7.96MHz	250	0.75	550
WF1008T1R5__	1.5@7.96MHz	J,K	12@7.96MHz	230	0.85	400
WF1008T1R8__	1.8@7.96MHz	J,K	12@7.96MHz	168	0.95	320
WF1008T2R2__	2.2@7.96MHz	J,K	12@7.96MHz	150	1.30	315
WF1008T2R7__	2.7@7.96MHz	J,K	12@7.96MHz	100	1.40	300
WF1008T3R3__	3.3@7.96MHz	J,K	12@7.96MHz	80	1.50	280
WF1008T3R9__	3.9@7.96MHz	J,K	12@7.96MHz	60	1.55	250
WF1008T4R7__	4.7@7.96MHz	J,K	12@7.96MHz	50	1.75	210
WF1008T5R6__	5.6@7.96MHz	J,K	12@7.96MHz	40	1.90	190
WF1008T6R8__	6.8@7.96MHz	J,K	12@7.96MHz	35	2.00	175
WF1008T7R5__	7.5@7.96MHz	J,K	12@7.96MHz	30	2.10	170
WF1008T8R2__	8.2@7.96MHz	J,K	12@7.96MHz	25	2.20	160
WF1008T100__	10@2.52MHz	J,K	10@2.52MHz	25	2.50	155
WF1008T120__	12@2.52MHz	J,K	10@2.52MHz	20	2.60	145
WF1008T150__	15@2.52MHz	J,K	10@2.52MHz	20	3.00	130
WF1008T180__	18@2.52MHz	J,K	10@2.52MHz	20	3.00	130
WF1008T220__	22@2.52MHz	J,K	10@2.52MHz	18	3.90	105
WF1008T270__	27@2.52MHz	J,K	10@2.52MHz	10	4.00	100
WF1008T330__	33@2.52MHz	J,K	10@2.52MHz	8	4.80	85
WF1008T390__	39@2.52MHz	J,K	10@2.52MHz	7	5.00	80
WF1008T470__	47@2.52MHz	J,K	10@2.52MHz	7	5.70	60
WF1008T560__	56@2.52MHz	J,K	10@2.52MHz	6.5	6.00	55
WF1008T680__	68@2.52MHz	J,K	10@2.52MHz	6.5	6.70	50
WF1008T820__	82@2.52MHz	J,K	10@2.52MHz	6.5	7.50	45
WF1008T101__	100@0.796MHz	J,K	8@0.796MHz	4.5	11.00	40
WF1008T121__	120@0.796MHz	J,K	8@0.796MHz	3	13.00	30
WF1008T151__	150@0.796MHz	J,K	8@0.796MHz	3	15.00	25
WF1008T221K	220@0.796MHz	K	8@0.796MHz	2.5	18.00	20





ELECTRICAL CHARACTERISTICS

1210 - TYPE

PART NUMBER	INDUCTANCE (μH)	INDUCTANCE TOLERANCE	Q MIN.	SRF (MHZ) MIN	RDC (Ω) MAX	IDC (mA)
WF1210TR12__	0.12@25.2MHz	J,K	20@25.2MHz	850	0.20	450
WF1210TR27__	0.27@25.2MHz	J,K	20@25.2MHz	700	0.20	450
WF1210TR33__	0.33@25.2MHz	J,K	20@25.2MHz	520	0.30	450
WF1210TR39__	0.39@25.2MHz	J,K	20@25.2MHz	500	0.30	450
WF1210TR47__	0.47@25.2MHz	J,K	20@25.2MHz	480	0.30	450
WF1210TR56__	0.56@25.2MHz	J,K	20@25.2MHz	450	0.30	450
WF1210TR68__	0.68@25.2MHz	J,K	20@25.2MHz	400	0.30	450
WF1210TR82__	0.82@25.2MHz	J,K	20@25.2MHz	350	0.30	450
WF1210T1R0__	1.0@7.96MHz	J,K	12@7.96MHz	220	0.30	450
WF1210T1R2__	1.2@7.96MHz	J,K	12@7.96MHz	210	0.30	450
WF1210T1R5__	1.5@7.96MHz	J,K	12@7.96MHz	200	0.40	450
WF1210T1R8__	1.8@7.96MHz	J,K	12@7.96MHz	195	0.50	450
WF1210T2R2__	2.2@7.96MHz	J,K	12@7.96MHz	175	0.60	450
WF1210T2R7__	2.7@7.96MHz	J,K	12@7.96MHz	120	0.70	420
WF1210T3R3__	3.3@7.96MHz	J,K	12@7.96MHz	80	1.10	380
WF1210T3R9__	3.9@7.96MHz	J,K	12@7.96MHz	75	1.20	360
WF1210T4R7__	4.7@7.96MHz	J,K	12@7.96MHz	60	1.30	350
WF1210T5R6__	5.6@7.96MHz	J,K	12@7.96MHz	50	2.00	320
WF1210T6R8__	6.8@7.96MHz	J,K	12@7.96MHz	35	1.50	310
WF1210T8R2__	8.2@7.96MHz	J,K	12@7.96MHz	35	1.60	305
WF1210T100__	10@2.52MHz	J,K	10@2.52MHz	30	1.00	300
WF1210T120__	12@2.52MHz	J,K	10@2.52MHz	25	1.20	265
WF1210T150__	15@2.52MHz	J,K	10@2.52MHz	22	2.00	225
WF1210T180__	18@2.52MHz	J,K	10@2.52MHz	22	2.10	210
WF1210T220__	22@2.52MHz	J,K	10@2.52MHz	20	2.40	200
WF1210T270__	27@2.52MHz	J,K	10@2.52MHz	18	2.70	180
WF1210T330__	33@2.52MHz	J,K	10@2.52MHz	15	2.90	160
WF1210T390__	39@2.52MHz	J,K	10@2.52MHz	16	4.70	150
WF1210T470__	47@2.52MHz	J,K	10@2.52MHz	10	5.20	140
WF1210T560__	56@2.52MHz	J,K	10@2.52MHz	8	5.60	125
WF1210T680__	68@2.52MHz	J,K	10@2.52MHz	5	4.70	110
WF1210T820__	82@2.52MHz	J,K	10@2.52MHz	5	5.60	100
WF1210T101__	100@0.796MHz	J,K	8@0.796MHz	5	6.80	95
WF1210T121__	120@0.796MHz	J,K	8@0.796MHz	4	7.90	85
WF1210T151__	150@0.796MHz	J,K	8@0.796MHz	4	9.00	80
WF1210T181__	180@0.796MHz	J,K	8@0.796MHz	3	14.50	70
WF1210T221__	220@0.796MHz	J,K	8@0.796MHz	2.6	16.50	65
WF1210T271K	270@0.796MHz	K	8@0.796MHz	2.5	18.00	60
WF1210T331K	330@0.796MHz	K	8@0.796MHz	2.3	19.00	55
WF1210T391K	390@0.796MHz	K	8@0.796MHz	2.2	21.50	45
WF1210T471K	470@0.796MHz	K	8@0.796MHz	2	22.50	40
WF1210T511K	560@0.796MHz	K	6@0.796MHz	1.5	28.00	30

ELECTRICAL CHARACTERISTICS

1812 - TYPE

PART NUMBER	INDUCTANCE (μH)	INDUCTANCE TOLERANCE	Q MIN.	SRF (MHZ) MIN	RDC (Ω) MAX	IDC (mA)
WF1812TR33	0.33@25.2MHz	J,K	10@25.2MHz	380	0.13	1000
WF1812TR47	0.47@25.2MHz	J,K	10@25.2MHz	330	0.14	1000
WF1812TR56	0.56@25.2MHz	J,K	10@25.2MHz	300	0.15	1000
WF1812TR82	0.82@25.2MHz	J,K	10@25.2MHz	250	0.20	1000
WF1812T1R0	1.0@7.96MHz	J,K	15@7.96MHz	200	0.22	1000
WF1812T1R2	1.2@7.96MHz	J,K	15@7.96MHz	200	0.35	1000
WF1812T1R5	1.5@7.96MHz	J,K	15@7.96MHz	180	0.32	1000
WF1812T1R8	1.8@7.96MHz	J,K	15@7.96MHz	160	0.35	950
WF1812T2R2	2.2@7.96MHz	J,K	15@7.96MHz	150	0.37	900
WF1812T2R7	2.7@7.96MHz	J,K	15@7.96MHz	145	0.37	850
WF1812T3R3	3.3@7.96MHz	J,K	15@7.96MHz	140	0.48	800
WF1812T3R9	3.9@7.96MHz	J,K	15@7.96MHz	135	0.60	750
WF1812T4R7	4.7@7.96MHz	J,K	15@7.96MHz	120	1.00	700
WF1812T5R6	5.6@7.96MHz	J,K	15@7.96MHz	110	0.55	650
WF1812T6R8	6.8@7.96MHz	J,K	15@7.96MHz	80	0.80	600
WF1812T8R2	8.2@7.96MHz	J,K	15@7.96MHz	70	0.85	600
WF1812T100	10@2.52MHz	J,K	10@2.52MHz	60	1.00	550
WF1812T120	12@2.52MHz	J,K	10@2.52MHz	55	1.10	550
WF1812T150	15@2.52MHz	J,K	10@2.52MHz	35	1.20	500
WF1812T180	18@2.52MHz	J,K	10@2.52MHz	29	1.20	500
WF1812T220	22@2.52MHz	J,K	10@2.52MHz	20	1.30	450
WF1812T270	27@2.52MHz	J,K	10@2.52MHz	20	1.50	400
WF1812T330	33@2.52MHz	J,K	10@2.52MHz	18	1.70	350
WF1812T390	39@2.52MHz	J,K	10@2.52MHz	14	1.80	350
WF1812T470	47@2.52MHz	J,K	10@2.52MHz	10	2.00	300
WF1812T560	56@2.52MHz	J,K	10@2.52MHz	10	2.20	290
WF1812T680	68@2.52MHz	J,K	10@2.52MHz	5.4	2.40	260
WF1812T820	82@2.52MHz	J,K	10@2.52MHz	5.2	2.80	240
WF1812T101	100@0.796MHz	J,K	10@0.796MHz	4	3.00	220
WF1812T121	120@0.796MHz	J,K	10@0.796MHz	3.3	3.30	220
WF1812T151	150@0.796MHz	J,K	10@0.796MHz	3	3.70	200
WF1812T181	180@0.796MHz	J,K	10@0.796MHz	3	4.50	200
WF1812T221	220@0.796MHz	J,K	10@0.796MHz	2.5	8.00	170
WF1812T271	270@0.796MHz	J,K	10@0.796MHz	2.2	8.50	160
WF1812T331K	330@0.796MHz	K	10@0.796MHz	2	9.00	150
WF1812T391K	390@0.796MHz	K	10@0.796MHz	1.8	9.50	130
WF1812T471K	470@0.796MHz	K	8@0.796MHz	1.6	12.00	120
WF1812T561K	560@0.796MHz	K	8@0.796MHz	1.5	12.50	110
WF1812T681K	680@0.796MHz	K	8@0.796MHz	1.5	14.00	100
WF1812T751K	750@0.796MHz	K	8@0.796MHz	1.5	14.50	95
WF1812T821K	820@0.796MHz	K	8@0.796MHz	1.5	15.00	95
WF1812T102K	1000@0.252MHz	K	6@0.252MHz	1.4	16.50	90

PRODUCT CHARACTERISTIC CURVE

0603

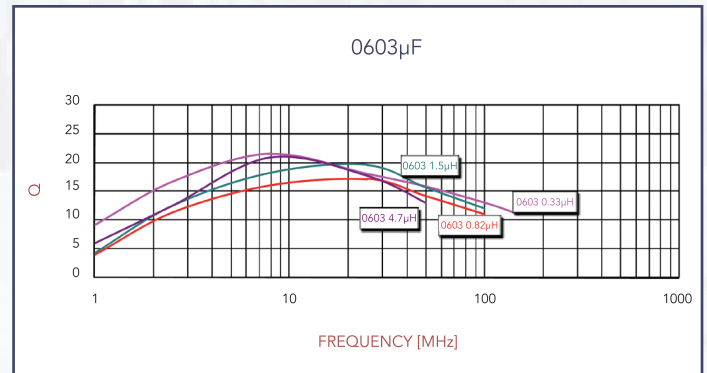
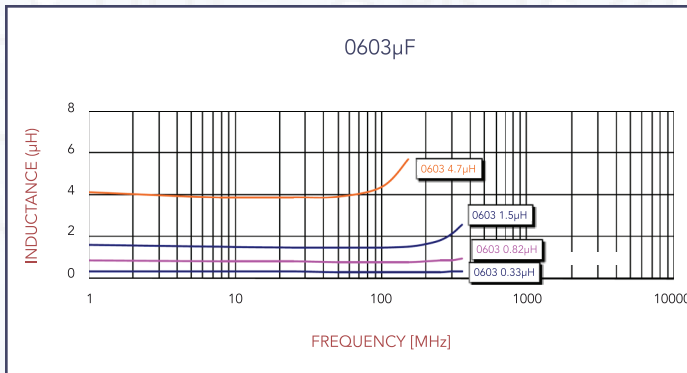

PRODUCT CHARACTERISTIC CURVE

0805

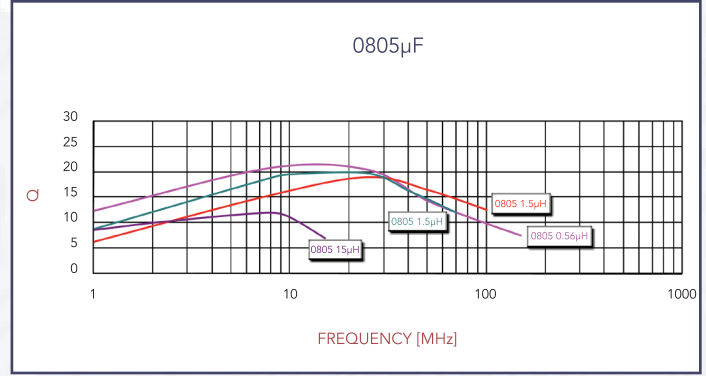
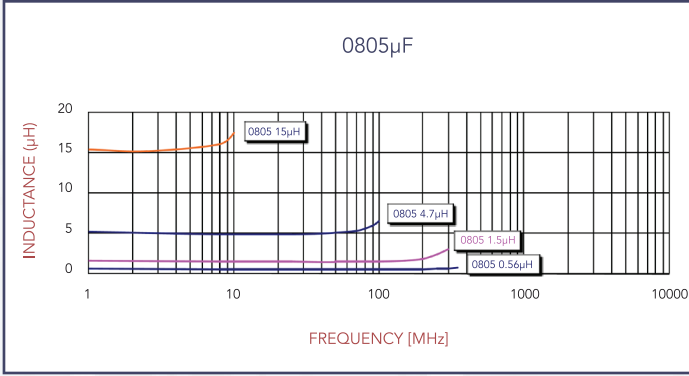

1008

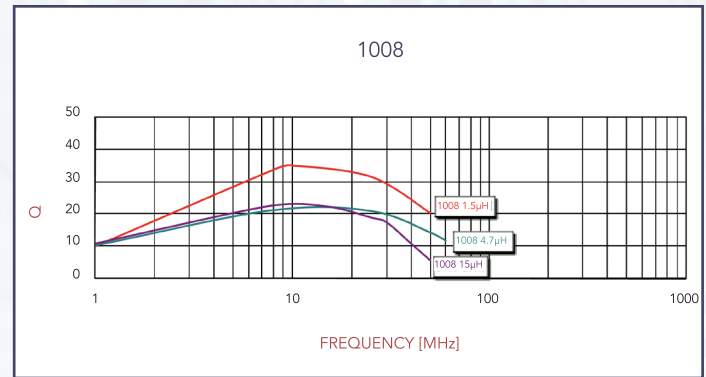
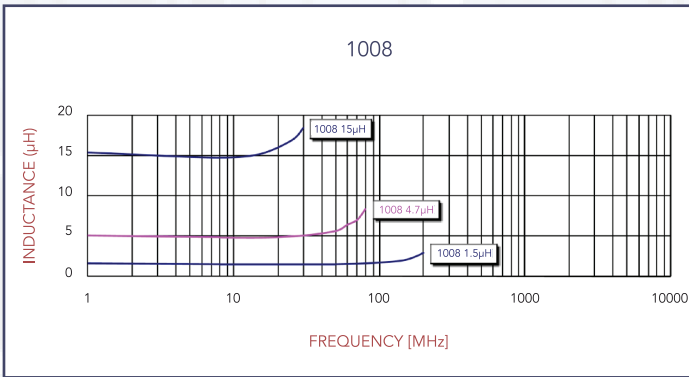

1210

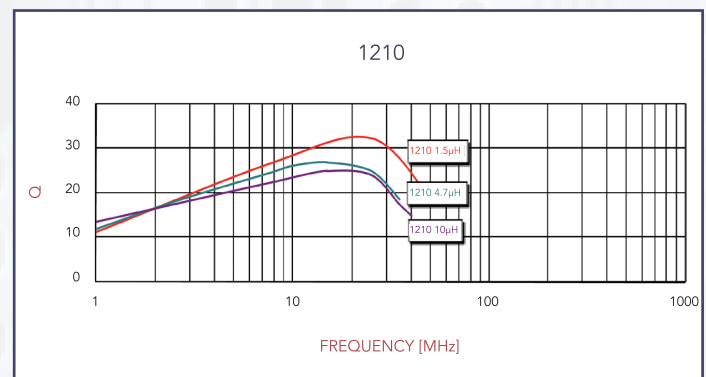
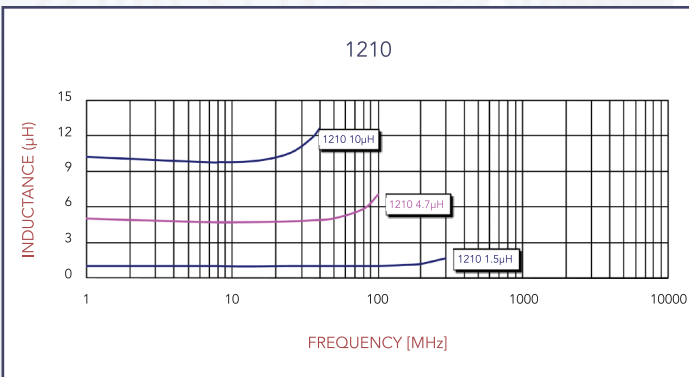

1812

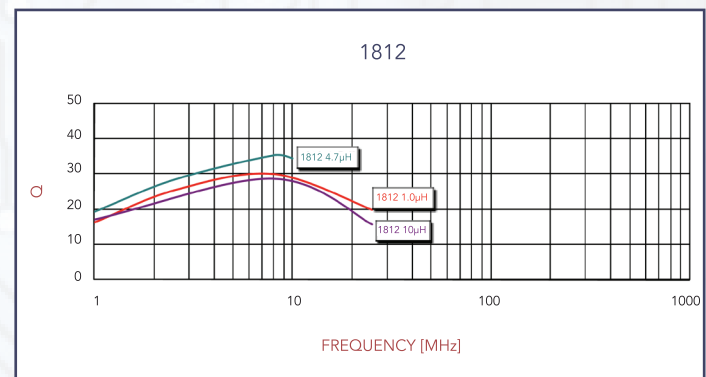
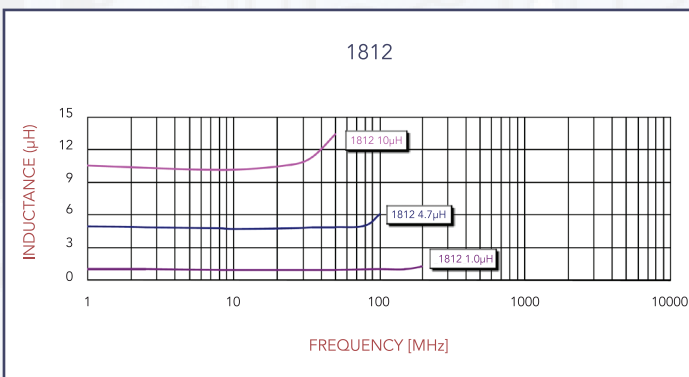

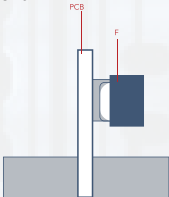

RELIABILITY TEST METHOD

NO.	ITEMS	REQUIREMENT	TEST METHOD										
1.	Solder Ability	No visible mechanical damage.	Dip pads in flux and dip in solder pot (96.5Sn/3.0Ag/0.5Cu) at 245±3°C for 3±0.3s.										
		Electrode surface solder coverage (Except exposed wire)											
2.	Resistance To Soldering	No visible mechanical damage	Dip pads in flux and dip in solder pot (96.5Sn/3.0Ag/0.5Cu) at 260±5°C for 10±1s.										
		Inductance shall not change more than ±5%											
		Q shall not change more than ±20%											
3.	Vibration	No visible mechanical damage.	Frequency 10Hz to 55Hz to 10Hz in a period of 1 minute for 2h in each of three(X, Y, Z) axes.										
		Inductance shall not change more than ±5%											
		Q shall not change more than ±20%											
4.	Adhesion of Electrode	The end electrode did not fall off after the test.	Weld the product on the PCB board, and apply force as shown in the diagram, direction and requirement. <table border="1" style="margin-top: 10px;"> <thead> <tr> <th>SIZE</th> <th>UL NO.</th> </tr> </thead> <tbody> <tr> <td>0603 Series</td> <td>7N</td> </tr> <tr> <td>0805 Series</td> <td>13N</td> </tr> <tr> <td>1008 and above Series</td> <td>20N</td> </tr> <tr> <td>Keep Time:</td> <td>(10 ± 1)s</td> </tr> </tbody> </table> 	SIZE	UL NO.	0603 Series	7N	0805 Series	13N	1008 and above Series	20N	Keep Time:	(10 ± 1)s
		SIZE		UL NO.									
0603 Series	7N												
0805 Series	13N												
1008 and above Series	20N												
Keep Time:	(10 ± 1)s												
No visible mechanical damage.													
5.	Low Temperature Resistance	No visible mechanical damage.	Shall be subjected to -40 ± 2°C for 1000h										
		Inductance shall not change more than ±5%											
		Q shall not change more than ±20%											
6.	High Temperature Resistance	No visible mechanical damage.	Shall be subjected to +85 ± 5°C for 1000h										
		Inductance shall not change more than ±5%											
		Q shall not change more than ±20%											
7.	Temperature Shock	No visible mechanical damage.	+85°C 30minutes ← → -40°C 30minutes 100 Cycles.										
		Inductance shall not change more than ±5%											
		Q shall not change more than ±20%											
8.	High Temperature Load	No visible mechanical damage.	shall be store at 85 ± 2°C for 1000h with rated current applied										
		Inductance shall not change more than ±5%											
		Q shall not change more than ±20%											
9.	Static Humidity	No visible mechanical damage.	Inductors shall be subjected to 90% ~ 95% RH. at 60 ± 2°C for 1000h										
		Inductance shall not change more than ±5%											
		Q shall not change more than ±20%											
10.	Bending Strength	No visible mechanical damage.	Install the inductor on the test substrate; Apply force in the vertical direction. The epoxy plate should bend down to (2 ± 0.2) mm at the bending rate of (1±0.5) mm/s, Keep time (30±1) sec.										



TAPING DRAWINGS

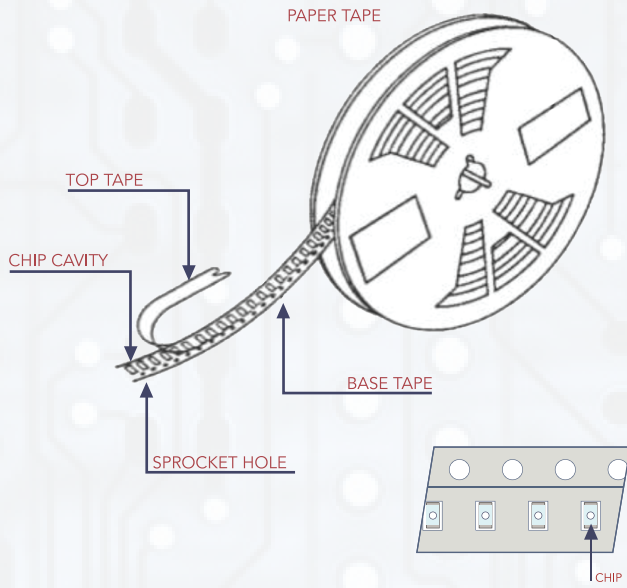

REEL DIMENSIONS

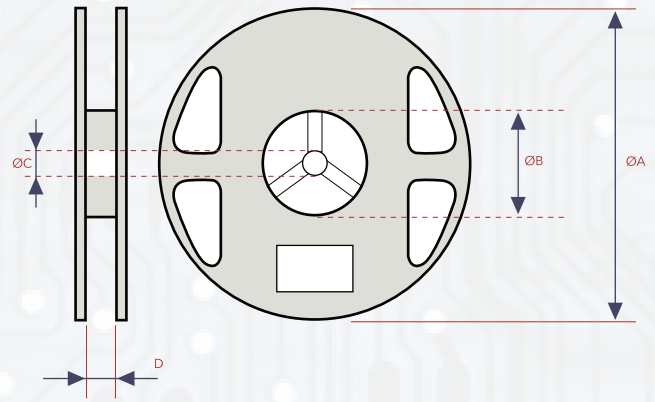

PART NO.	$\varnothing A$ TYPE	$\varnothing B$ TYPE	$\varnothing C$ TYPE	D TYPE
WF0603-1210	178	60	13	8.4
WF1812	1812	330	98	13

LEADER AND BLANK PORTION

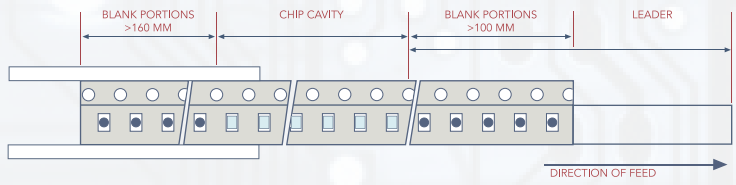

TAPING DIMENSIONS
- Paper Tape

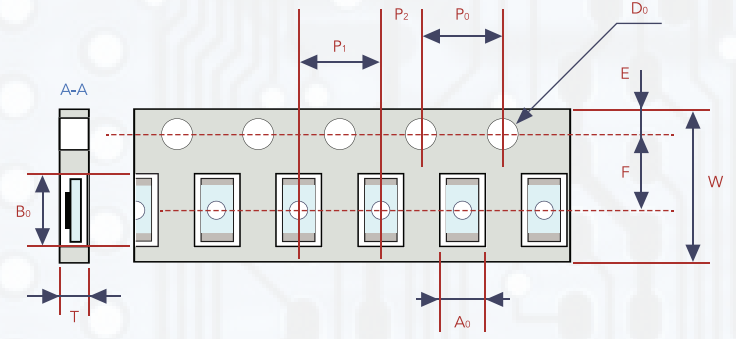

PART NO.	W	E	F	D0	P0	P1	P2	P0 X 10	A0	B0	T
WF0402	8.00	1.75	3.50	1.55	4	2	2	40	0.74	1.23	0.68
WF0603	8.00	1.75	3.50	1.55	4	4	2	30	1.20	1.85	1.00

PACKAGING

EMBOSSED TAPE

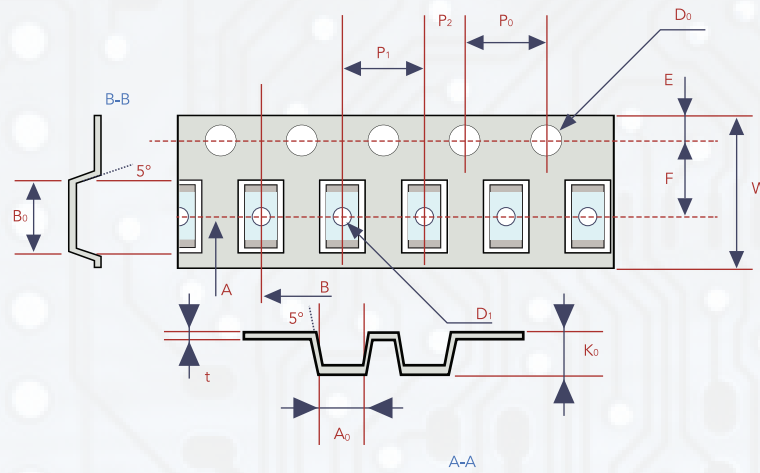

PART NO.	W	E	F	D0	D1	P0	P1	P2	P0 X 10	t	A0	B0	K0
WF0603	8.00	1.75	3.50	1.55	0.60	4	4	2	40	0.22	1.20	1.85	1.10
WF0805	8.00	1.75	3.50	1.55	0.65	4	4	2	40	0.23	1.85	2.45	1.50
WF1008	8.00	1.75	3.50	1.55	0.65	4	4	2	40	0.25	2.73	2.90	2.34
WF1210	8.00	1.75	3.50	1.55	0.65	4	4	2	40	0.23	2.96	3.60	2.40
WF1812	8.00	1.75	3.50	1.55	1.50	4	8	2	40	0.25	3.22	4.82	2.98

PEELING FORCE

- Peeling Required

0603 ~ 1210 series: 10g ~ 80g
 1812 series: 10g ~ 100g

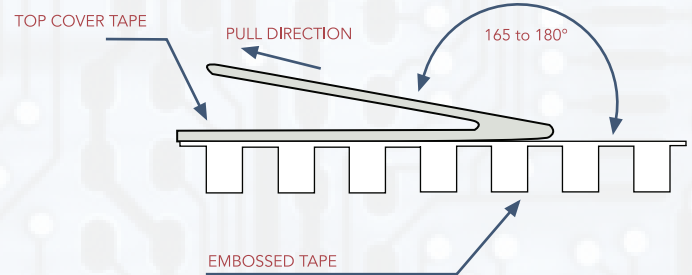
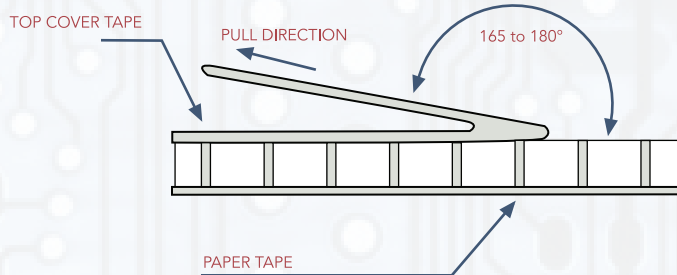

TEST REQUIRED

- Speed of peeling off: 300mm/min±10%
- Angle of peeling off: 165° ~ 180°

SIZE	0603	0805	1008	1210	1812
PER REEL	4000	3000	2000	2000	2000



RECOMMENDED SOLDERING CONDITIONS

- Soldering Conditions
Applicable soldering process to the products is reflow soldering.
- Flux, Solder
Don't use highly acidic flux with halide content exceeding 0.2(wt%)(chlorine conversion value).
Using lead-free solder (96.5Sn /3.0Ag/0.5Cu).
- Soldering Conditions
Pre-heating should be in such a way that the temperature difference between solder and ferrite surface is limited to 150°C max. Also cooling into solvent after soldering should be in such way that the temperature difference is limited to 100°C max. Un-enough pre-heating may cause cracks on the ferrite, resulting in the deterioration of product quality.
Products should be soldered within the following allowable range indicated by the slanted line. The excessive soldering conditions may cause the corrosion of the electrode. When soldering is repeated, allowable time is the accumulated time
- Reflow Soldering Profile
Preheat condition: 150 ~ 200°C/ 60 ~ 120sec
max temp: 260°C
max time at max temp: 10 sec
Allowed Reflow time: 3x max
- Iron Soldering
Perform soldering at 350°C on 30W max.
Soldering Time: < 5S (Take care not to apply the tip of the soldering iron to the terminal electrodes)

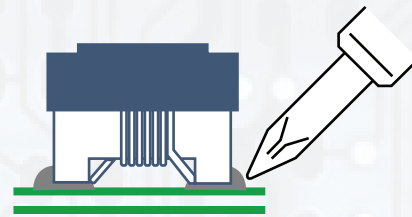
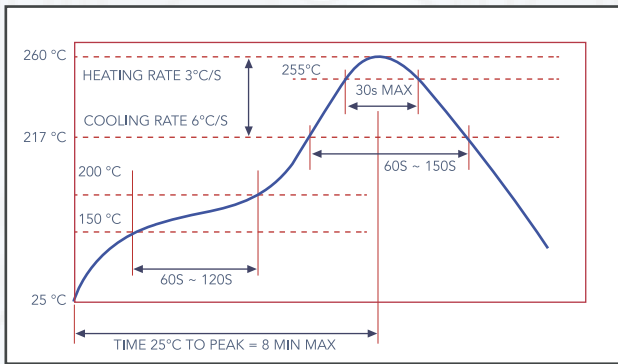

STORAGE METHODS

- Storage period
Please use the products within 1 year since the factory inspection before the delivery, the welding performance should be checked before use if the storage time exceeds 1year.
- Storage conditions
Products should be storage in the warehouse on the following conditions:
Temperature: -10~+40°C Humidity: 30~70% relative humidity
- Don't keep products in corrosive gases such as sulfur, chlorine gas or acid , or it may case oxidization of Electrodes resulting in poor solder abilityY.
- Products should be stored on the palette for the prevention of the influence from humidity, dust and so on.
- Products should be stored in the warehouse without heat shock, vibration, direct sunlight and so on.
- Products should be stored under the airtight packaged condition

PRECAUTIONS FOR USE

- This product specification guarantees the quality of our product as a single unit, Please make sure that your product has been evaluated and confirmed against your specifications when our product is mounted to your product.
- We can't warrant against failure caused by any use of our product that deviates from the intended use as described in this product specification.
- Do not touch wire with sharp objects such as tweezers to prevent wire breakage

CORRECT METHOD Tweezers should support on both sides of the chip		WRONGLY METHOD Tweezers should not support on enameled wire of the chip	
	✓		✗
			✗
			✗

