

ULTRA-HIGH POWER THICK FILM CHIP RESISTORS

- UPR SERIES -

SCOPE

- Applies to larger size thick film resistors with ultra high power ratings
- This specification for approval relates to Ultra-High Power Thick Film Chip Resistors manufactured by Cal-Chip Electronics Inc.'s specifications.

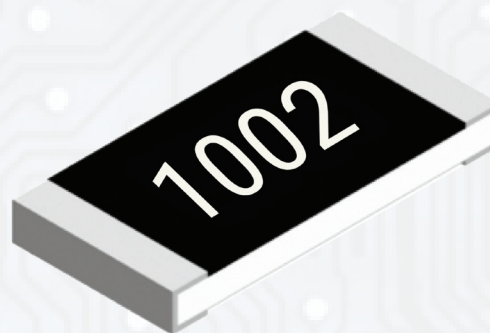

APPLICATIONS

- Telecommunication Equipment
- Computers
- Measuring Instruments
- Military Equipment
- Automotive Equipment

FEATURES

- High Reliability
- AEC-Q200 Compliant

CONSTRUCTION

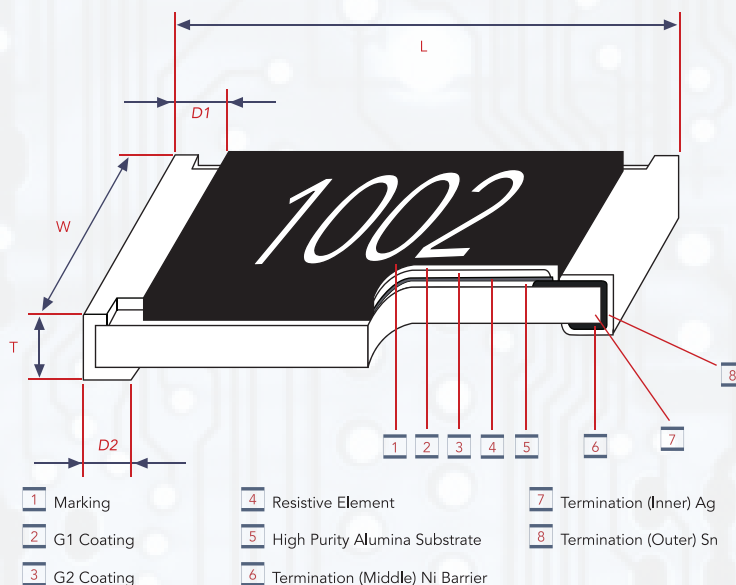

TYPE	SIZE (INCH)	L	W	T	D1	D2
UPR20	2010	5.00 ± 0.10	2.50 ± 0.15	1.10 ± 0.10	0.60 ± 0.25	0.50 ± 0.20
UPR25	2512	6.35 ± 0.10	3.20 ± 0.15			1.80 ± 0.20
UPR28	2817	7.10 ± 0.20	4.20 ± 0.20	1.10 ± 0.10	0.80 ± 0.20	2.40 ± 0.20
UPR43	4320	11.00 ± 0.30	5.00 ± 0.25			2.50 ± 0.20
UPR45	4527	11.60 ± 0.30	6.85 ± 0.25			

PART NUMBERING

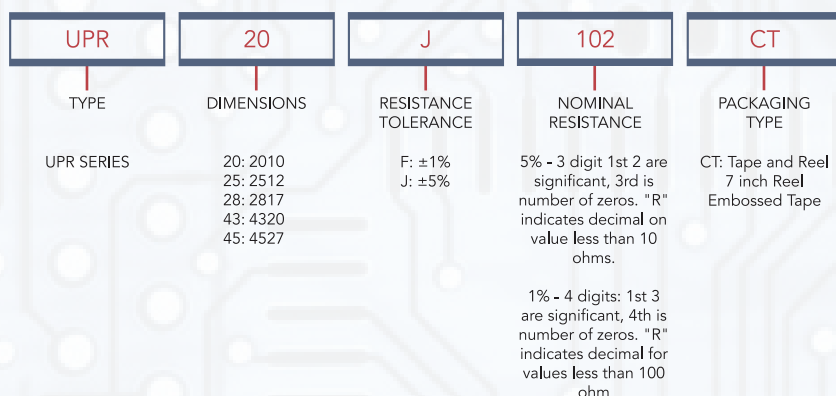

POWER RATING

- Resistors shall have a power rating based on continuous load operation at an ambient temperature of 70°C. For temperature in excess of 70°C, The load shall be derate as shown below:

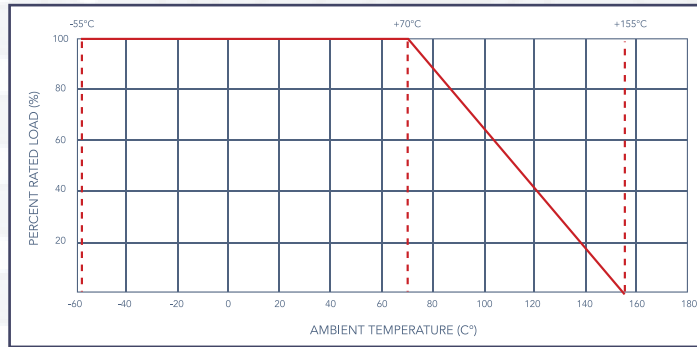

TYPE	ITEM	POWER RATING AT 70°C	MAX WORKING VOLTAGE	MAX OVERLOAD VOLTAGE	DIELECTRIC WITHSTANDING VOLTAGE	TEMPERATURE RANGE	AMBIENT TEMPERATURE
UPR20	2010	2W	200V	500V	500V	-55°C ~ 155°C	70°C
UPR25	2512	3W	250V	500V	500V		
UPR28	2817	4W	250V	500V	500V		
UPR43	4320	5W	300V	600V	600V		
UPR45	4527	6W	300V	600V	600V		

TYPE	ITEM	POWER RATING AT 70°C	TOLERANCE %	RESISTANCE RANGE	STANDARD SERIES
UPR20	2010	2W	±1	1Ω ~ 10MΩ	E-96
			±5		E-24
UPR25	2512	3W	±1		E-96
			±5		E-24
UPR28	2817	4W	±1		E-96
			±5		E-24
UPR43	4320	5W	±1		E-96
			±5		E-24
UPR45	4527	6W	±1		E-96
			±5		E-24

NOMINAL RESISTANCE

- Effective figures of nominal resistance shall be in accordance:

E-24 Values - these are preferred and will have standard MOQ

E-96 values – are available on case by case basis and availability and MOQ need to be confirmed with factory first

THERMAL RESISTANCE

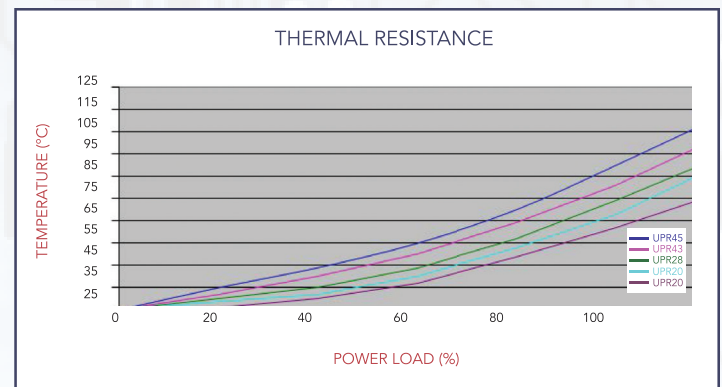

VOLTAGE RATING

Resistors shall have a rated direct-current (DC) continuous working voltage or an approximate sine-wave root-mean-square (RMS) alternating-current (AC) continuous working voltage at commercial line frequency and waveform corresponding to the power rating, as determined from the following formula:

$$RCWV = \sqrt{P \times R}$$

NOTE: Max. Working Voltage or $\sqrt{P \times R}$ whichever is lesser
 Max. Overload Voltage or $2.5 \sqrt{P \times R}$ whichever is lesser

WHERE: RCWV = Rated DC or RMS AC continuous working voltage at commercial-line frequency and waveform (volt)

P: Power Rating (watt)
 R: Nominal Resistance (ohm)

MARKING

RESISTORS

Marking for E-96 series in UPR20, UPR25, UPR28, UPR43, UPR45 size: 4 Digits

- The first 3 digits are significant figures of resistance and the 4th digit denoted number of zeros.



Marking for E-24 series in UPR20, UPR25, UPR28, UPR43, UPR45 size: 3 Digits

- The first 2 digits are significant figures of resistance and the 3rd digit denoted number of zeros.



- For ohmic values below 100 Ω, letter "R" is for decimal point.



- For ohmic values below 10 Ω, letter "R" is for decimal point.



LABELS

- Label shall be marked with the following item:

- CCE Part Number
- Customer part Number if Applicable
- Quantity
- Date Code
- Lot Number

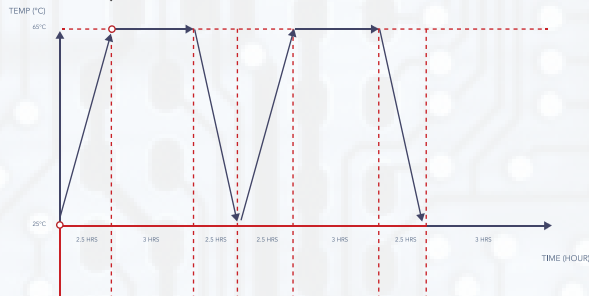

PERFORMANCE SPECIFICATION

CHARACTERISTICS	LIMITS	TEST MEHODS (AEC Q-200)
Operational Life	Resistance change rate is ±1%: ±(1.0%+0.1Ω)max ±5%: ±(3.0%+0.1Ω)Max.	125°C, at 35% of operating power, 1000H (1.5 hours "ON", 0.5 hour "OFF"). (MIL-STD-202 Method 108)
Temperature Coefficient	Resistance change rate is 1Ω < R ≤ 10Ω : ±200PPM/°C 10.1Ω < R ≤ 10MΩ : ±100PPM/°C	Natural resistance change per temp. degree centigrade $\frac{R2 - R1}{R1 (t2-t1)}$ R1: Resistance value at room temperature (T1) R2: Resistance value at room temp. plus 100°C (T2) Test pattern: room temp. (T1), room temp. +100°C (T2)
Short Time Overload	Resistance change rate is ±1%: ±(1.0%+0.1Ω)Max ±5%: ±(2.0%+0.1Ω)Max	2.5x Rated voltage or Max. Overload Voltage whichever is lower for 5 seconds, then check the resistance.
External Visual	No Mechanical Damage	Electrical test not required. Inspect device construction, marking and workmanship (MIL-STD-883 Method 2009)
Physical Dimension	Reference 2.0 Dimension Standards	Verify physical dimenions to the applicable device detail specification. Note: User(s) and Suppliers spec. Electrical test not required. (JESD22 MH Method JB-100)
Resistance to Solvent	Marking Unsmearred	Note: Add Aqueous wash chemical - okem Clean or equivalent. Do not use banned solvents. (MIL-STD-202-Method 215)
Terminal Strength	Not Broken	Force of 1.8kg for 60 seconds. (JIS-C6429)
High Temperature Exposure (Storage)	Resistance change rate is ±(1.0%+-1Ω) max	1000 hrs. @T=155°C. Unpowered. Measurement at 24±2 hours after test conclusion. (MIL-STD-202 Method 108)
Temperature Cycling	Resistance change rate is 1%: ±(0.5%+0.1Ω) Max. 5%: ±(1.0%+0.1Ω) Max.	1000 Cycles (-55C to +155°C). Measurement at 24±2 hours after test conclusion. (JESD22 Method JA-104)
Moisture Resistance	Resistance change rate is 1%: ±(0.5%+0.1Ω) Max. 5%: ±(3.0%+0.1Ω) Max.	 <p>T=24 hours /cycle. Unpowered. Measurement at 24±2 hours after test conclusion. (MIL-STD-202 Method 106)</p>
Biased Humidity	Resistance change rate is 1%: ±(0.5%+0.1Ω) Max. 5%: ±(3.0%+0.1Ω) Max.	10% rated power, 85°C / 85% RH, 1000H, Measurement at 24 hours after test conclusion. (MIL-STD-202 Method 103)
Mechanical Shocks	Resistance change rate is ±(1.0%+0.1Ω) max	Wave Form: Tolerance for half sine shock pulse. Peak value is 100g's. Normal duration (D) is 6. (MIL-STD-202 Method 213)
Vibration	Resistance change rate is ±(1.0%+0.1Ω) max	5g's for 20 min., 12cycle each of 3 orientations. Note: Use 8"*5"PCB. 031" thick 7 secure points (on one) long side and 2 secure points at corners of opposite sides. Parts mounted within 2' from any secure point. Test from 10-2000Hz. (MIL-STD-202 Method 204)
Thermal Shock	Resistance change rate is ±(1.0%+0.1Ω) max	-55°C/+155°C, Note: Number of cycles required -300, Maximum transfer time -20 seconds, Dwell time -15 minutes. Air-Air. (MIL-STD-202 Method 107)



PERFORMANCE SPECIFICATION

CHARACTERISTICS	LIMITS	TEST MEHODS (AEC Q-200)
ESD	Resistance change rate is $\pm(10\%+0.1\Omega)\text{max}$	With the electrometer in direct contact with the discharge tip, verify the voltage setting at levels of $\pm 500\text{V}, \pm 1\text{KV}, \pm 2\text{KV}, \pm 4\text{KV}, \pm 8\text{KV}$, The electrometer reading shall be within $\pm 10\%$ for voltages from 500V to $\leq 800\text{V}$. (AEC-Q200-002)
Solderability	95% coverage Min.	For both leaded & SMD. Electrical test not required. Magnification 50X. Conditions: a) Method B 4hrs at 155°C dry heat, the dip in bath with 245°C, 5s. b) Method B: at 215°C, 5s. c) Method D: at 260°C, 60s. (J-STD-002)
Flammability	No ignition of the tissue paper or scorching or the pinewood board	V-0 or V-1 are acceptable. Electrical test not required. (UL-94)
Board Flex	Resistance change rate is $\pm(1.0\% + 0.05\Omega)\text{max}$	2mm (Min) (JIS-C-6429)
Flame Retardance	No Flame	Temperature sensing at 500°C, Voltage power subjected to 32VDC current clamped up to 500ADC and decreased in 1.0VDC/hour. (AEC-Q200-001)
Resistance to Soldering Heat	Resistance change rate is $\pm(1.0\% + 0.05\Omega)\text{max}$.	Condition B No per-heat of samples. Note: Single Wave Solder - Procedure 2 for SMD and Procedure 1 for Leaded with solder within 1.5mm of device body. (MIL-STD-202 Method 210)

PACKING SPECIFICATION

TAPING DIMENSION (MM)

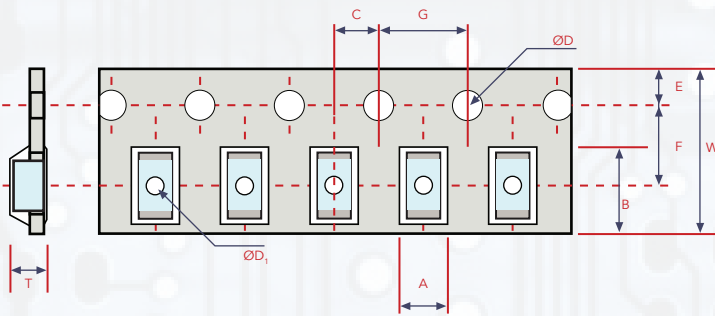

REEL DIMENSION (MM)

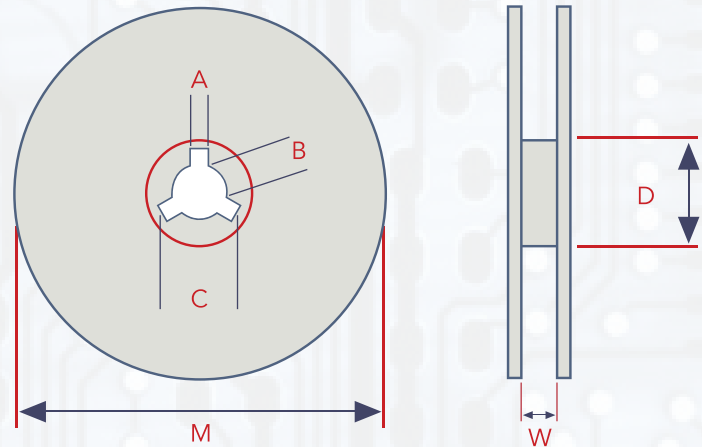

TYPE	A ± 0.1	B ± 0.1	C ± 0.15	ØD $\pm 0.1-0$	E ± 0.15	F ± 0.15	G ± 0.1	W ± 0.30	ØD ₁ ± 0.1	T ± 0.1
UPR20	2.65	5.25	2.0	1.5	1.75	5.5	4.0	12	1.0	1.35
UPR25	3.50	6.7				5.5		12	1.5	
UPR28	4.50	7.4	7.5	16	-					
UPR43	5.40	11.5	11.5	24	-					
UPR45	7.20	11.9	11.5	24	-					

TYPE	ITEM	QTY/ REEL	A ± 0.5	B ± 0.5	C ± 0.5	D ± 1	M ± 2	W ± 1
UPR20	2010	2,000 pcs	2.0	13.0	21.0	60.0	178	13.5
UPR25	2512	2,000 pcs						13.5
UPR28	2817	1,000 pcs						17.5
UPR43	4320	1,000 pcs						25.5
UPR45	4527	1,000 pcs						25.5

PEELING STRENGTH OF TOP COVER TAPE

- Test Condition: 0.1 to 0.7 N at peel-off speed of 300mm/min.

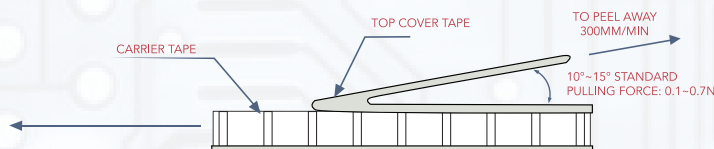

ENVIRONMENT RELATED SUBSTANCE

- This product complies to EU RoHS directive, EU PAHs directive, EU PFOS directive and Halogen free. Ozone layer depleting substances. Ozone depleting substances are not used in our manufacturing process of this product.
- This product is not manufactured using Chloro fluorocarbons (CFCs), Hydrochlorofluorocarbons (HCFCs), Hydrobromofluorocarbons (HBFCs) or other ozone depleting substances in any phase of the manufacturing process.

STORAGE CONDITION

- The performance of these products, including the solderability, is guaranteed for a year from the date of arrival at your company, provided that they remain packed as they were when delivered and stored at a temperature of $25^{\circ}\text{C} \pm 10^{\circ}\text{C}$ and a relative humidity of $60\%RH \pm 10\%RH$, chemical and dust free atmosphere

Even within the above guarantee periods, do not store these products in the following conditions. Otherwise, their electrical performance and/or solderability may be deteriorated, and the packaging materials (e.g. taping materials) may be deformed or deteriorated, resulting in mounting failures.

1. In salty air or in air with a high concentration of corrosive gas, such as Cl_2 , H_2S , NH_3 , SO_2 , or NO_2
2. In direct sunlight

RECOMMENDED SOLDER PAD

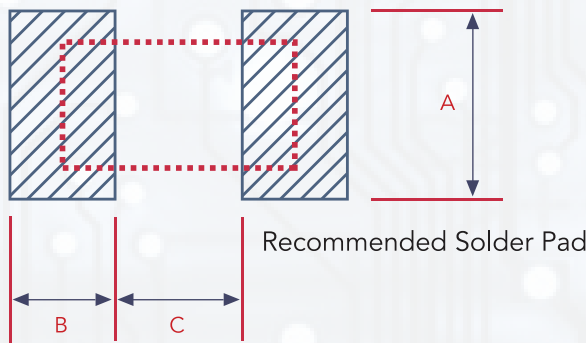

TYPE	ITEM	A	B	C
UPR20	2010	3.00	2.00	3.90
UPR25	2512	3.70	3.30	2.70
UPR28	2817	4.70	3.30	3.40
UPR43	4320	5.50	3.90	6.10
UPR45	4527	7.20	4.00	6.50

- 4 layers PCB specification:
 - 1) Outside 2 layers (Top and Bottom) with copper foil thickness at 2oz.
 - 2) Inside 2 layers (Middle layers) with copper foil thickness at 4 oz.
- This production is used for automotive electronics, CAL-CHIP ELECTRONICS INC. will not be responsible for any damage, expense or loss caused by the use of this specification in any special environment. This series of product are suitable for automotive electronics applications, as show below, if there are other application, you need to confirm with CAL-CHIP ELECTRONICS INC. whether they are applicable:
 - a. Control unit for informatiom, entertainment, navigation, audio;
 - b. Control unit for comfortable doors, windows, seat;
 - c. Control unit for internal lighting.

