

T0-220 POWER RESISTOR

- RTR20 SERIES -

FEATURES

- 20 Watts at 25°C case temperature heat sink mounted.
- T0-220 style power package
- Molded case for protection and easy to mount
- Electrically isolated case
- Non-Inductive design

APPLICATIONS

- High Speed Switching Power Supplies
- Snubber Circuits
- Load Resistor for Pulse Generators
- Voltage Regulation
- VHF Amplifiers

CONSTRUCTION

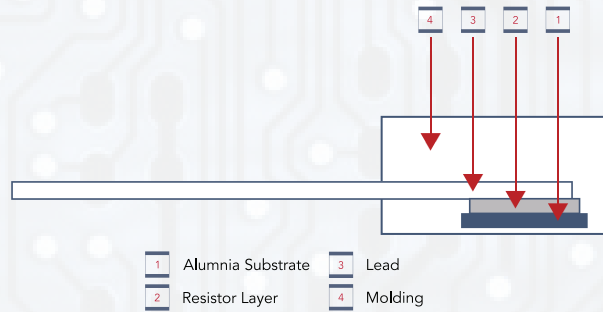

PART NUMBERING

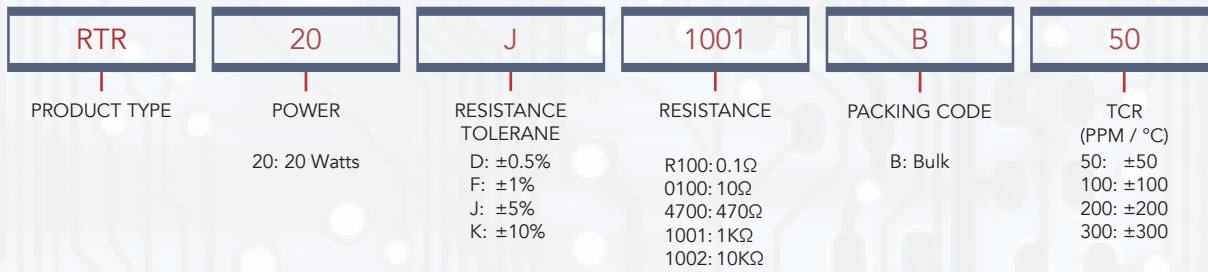

DIMENSIONS

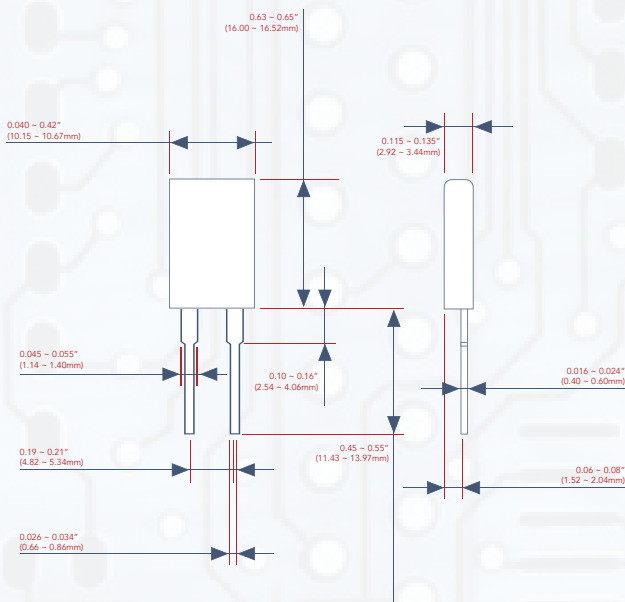

DERATING CURVE

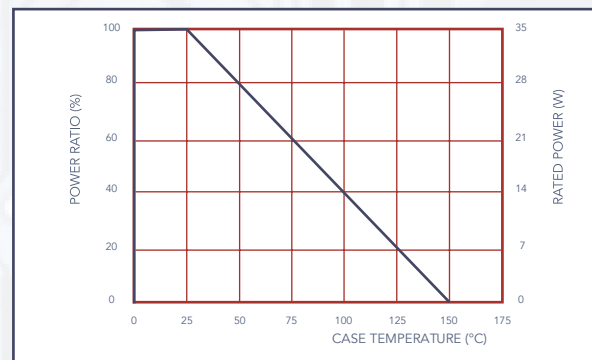

TYPE	WEIGHT (G) (1000 PCS)
RTR20	1290

ELECTRICAL CHARACTERISTICS SPECIFICATIONS

TYPE	ITEM	RESISTANCE RANGE				TCR (PPM/°C)
		±0.5%	±1%	±5%	±10%	
RTR20	-	-	-	0.05Ω - 1Ω		Not Specified
	-	-	≥ 1Ω - 3Ω		± 300	
	-	-	≥ 3Ω - 10Ω		±100 ±200	
	-	-	≥ 10Ω - 1MΩ		±50 ±100 ±200	

- Operating Voltage: 350V Max
- Dielectric Strength: 1800VAC
- Insulation Resistance: 10GΩ min.
- Working Temperature Range: -65°C to +150°C
- Resistance Value <1Ω is available

ENVIRONMENTAL CHARACTERISTICS

ITEM	REQUIREMENT	TEST METHOD
Temperature Coefficient of Resistance (T.C.R.)	As Spec.	Referenced to 25°C, DR taken at +105°C
Short Time Overload	ΔR ± 0.3%	2 times rated power with applied voltage not to exceed 1.5 times maximum continuous operating voltage for 5 seconds
Load Life	ΔR ± 1.0%	2,000 hours at rated power
Damp Heat with Load	ΔR ± 0.5%	40±2°C, 90~95% R.H., RCWW for 1000 hrs with 1.5 hrs "ON" and 0.5 hrs "OFF"
Solderability	90% min coverage	245±5°C for 3 seconds
Thermal Shock	ΔR ± 0.3%	-65°C ~150°C, 100 cycles
Terminal Strength	ΔR ± 0.2%	(Pull Test) 2.4N
Vibration, High Frequency	ΔR ± 0.2%	20g peak

RCWW (Rated Continuous Working Voltage) $-\sqrt{(P \cdot R)}$ or Max. Operating Voltage whichever is lower.

- Lead Material: Tinned Copper
- Without a Heat Sink
- When in Free Air at 25°C, the RTR20 is Rated for 3W.
- The Case Temperature is to be used for the Definition of the Applied Power Limit.
- The Case Temperature Measurement Must be Made with a Thermocouple Contacting the Center of the Component Mounted on the Designed Heat Sink.
- Thermal Grease Should be Applied Properly.

