

THICK FILM CURRENT SENSING CHIP RESISTOR

- RST SERIES -



SCOPE

- This specification applies to all sizes of rectangular-type fixed chip resistors with Ruthenium-base as material.

FEATURES

- Low Inductance
- Highly reliable multilayer electrode construction
- Higher component and equipment reliability
- Reduced size of final equipment reliability.

APPLICATIONS

- Power Mangement Applications
- Switching Power Supply
- Over Current Protection in Audio Application
- Voltage Regulation Module (VRM)
- DC-DC Converter, Battery Pack, Charger, Adaptor
- Automotive Engine Control
- Disk Driver

CONSTRUCTION

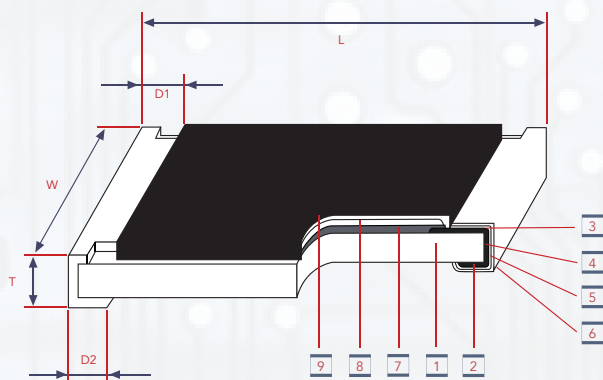

- 1 Alumina Substrate
- 2 Bottom Electrode (Ag)
- 3 Top Electrode (Ag-pd)
- 4 Edge Electrode (NiCr)
- 5 Barrier Layer (Ni)
- 6 External Electrode (Sn)
- 7 Resistor Layer (RuO₂/Ag)
- 8 Primary Overcoat (Glass)
- 9 Secondary Overcoat (Epoxy)

TYPE	SIZE (INCH)	L	W	T	D1	D2	WEIGHT (G) (1000PCS)
RST04	0402	1.00±0.05	0.50±0.05	0.35±0.05	0.20±0.10	0.20±0.10	0.620
RST06	0603	1.60±0.10	0.80±0.10	0.45±0.10	0.30±0.20	0.30±0.20	2.042
RST10	0805	2.00±0.10	1.25±0.10	0.50±0.10	0.35±0.20	0.40±0.20	4.368
RST12	1206	3.10±0.10	1.55±0.10	0.55±0.10	0.50±0.25	0.50±0.20	8.947
RST14	1210		2.60±0.15				15.959
RST20	2010	5.00±0.10	2.50±0.15	0.60±0.25			24.241
RST25	2512	6.35±0.10	3.10±0.15				39.448

PART NUMBERING

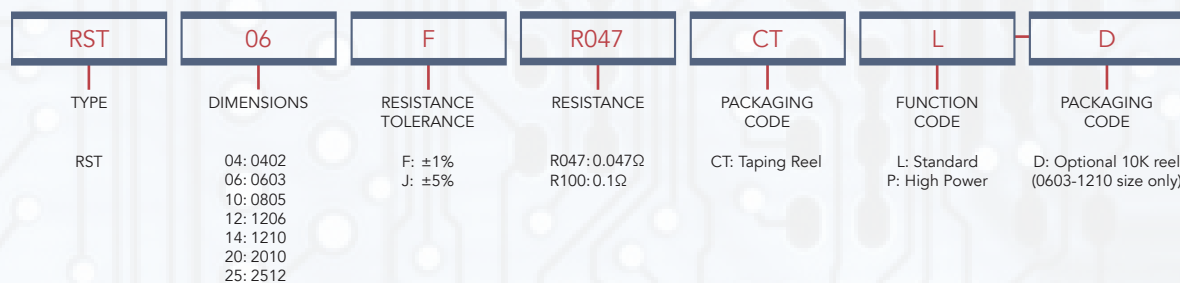

DERATING CURVE

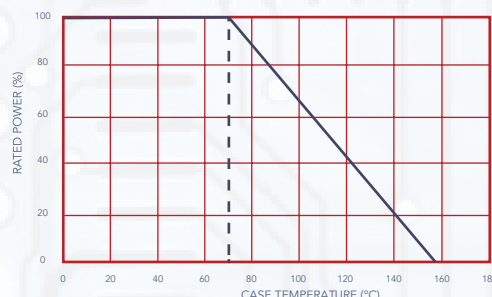

STANDARD ELECTRICAL SPECIFICATIONS

TYPE	ITEM	POWER RATING AT 70°C	OPERATING TEMP RANGE	MAX OPERATING CURRENT	RESISTANCE RANGE (mΩ)		T.C.R. (PPM / °C)
					±1%	±5%	
RST04	0402	1/16W	-55~+155°C	1.11A	50 - 91 100 - 976	±800 ±500	
RST06	0603	1/10W		2.23A	20 - 47 50 - 91 100 - 976	±1200 ±800 ±500	
RST10	0805	1/8W		3.53A	10 - 18 20 - 47	±1500 ±1200	
RST12	1206	1/4W		5.00A	50 - 91 100 - 976	±800 ±500	
RST14	1210	1/3W		5.77A	10 - 18 20 - 91 100 - 976	±1500 ±800 ±500	
RST20	2010	3/4W		8.66A			
RST25	2512	1W		10.0A			

Operating Voltage - $\sqrt{(P^*R)}$;

Overload Voltage - $2.5 * \sqrt{(P^*R)}$;

HIGH POWER ELECTRICAL SPECIFICATIONS

TYPE	ITEM	POWER RATING AT 70°C	OPERATING TEMP RANGE	MAX OPERATING CURRENT	RESISTANCE RANGE (mΩ)		T.C.R. (PPM / °C)
					±1%	±5%	
RST04	0402	1/10W	-55~+155°C	1.40A	50 - 91 100 - 976	±800 ±500	
RST06	0603	1/8W		2.50A	20 - 47 50 - 91 100 - 976	±1200 ±800 ±500	
RST10	0805	1/4W		5.00A	10 - 18 20 - 47	±1500 ±1200	
RST12	1206	1/3W		5.77A	50 - 91 100 - 976	±800 ±500	
RST14	1210	1/2W		7.07A	10 - 18 20 - 91 100 - 976	±1500 ±800 ±500	
RST20	2010	1W		10.0A			
RST25	2512	2W		14.1A			

Operating Voltage - $\sqrt{(P^*R)}$; Overload Voltage - $2.5 * \sqrt{(P^*R)}$; Operating Current - $\sqrt{(P^*R)}$
Cal-Chip is capable of manufacturing the optional spec based on customer's requirement.

ENVIRONMENTAL CHARACTERISTICS

ITEMS	REQUIREMENT		TEST METHOD
	±1%	±5%	
Temperature Coefficient of Resistance (T.C.R.)	As Spec.		JIS-C-5201-1 4.8 IEC-60115-1 4.8 -55°C~+125°C, 25°C is the reference temperature
Short Time Overload	±(1.0% + 0.05Ω)	±(2.0% + 0.05Ω)	JIS-C-5201-1 4.13 IEC-60115-1 4.13 RCWV *2.5 or Max. Overload Voltage whichever is lower for 5 seconds, 2 seconds for High Power Series
Insulation Resistance	≥10G		JIS-C-5201-1 4.6 IEC-60115-1 4.6 Max. Overload Voltage for 1 minute
Endurance	±(1.0% + 0.10Ω)	±(2.0% + 0.10Ω)	JIS-C-5201-1 4.25 IEC-60115-1 4.25.1 70±2°C, RCWV for 1000 hrs with 1.5hrs "ON" and 0.5 hrs "OFF"
Damp Heat with Load	±(1.0% + 0.10Ω)	±(2.0% + 0.10Ω)	JIS-C-5201-1 4.24 IEC-60115-1 4.24 40±2°C, 90%~95% R.H., RCWV for 1000 hrs with 1.5hrs "ON" and 0.5 hrs "OFF"
Dry Heat	±(1.0% + 0.05Ω)	±(1.5% + 0.10Ω)	JIS-C-5201-1 4.23 IEC-60115-1 4.23.2 at +155°C for 1000 hrs
Bending Strength	±(1.0% + 0.05Ω)	±(1.0% + 0.05Ω)	JIS-C-5201-1 4.33 IEC-60115-1 4.33 Bending once for 5 seconds 2010, 2512 sizes: 2mm Other sizes: 3mm
Soldering	95% min. coverage		JIS-C-5201-1 4.17 IEC-60115-1 4.17 245 ± 5°C for 10 seconds
Resistance to Soldering Heat	±(0.5% + 0.05Ω)	±(1.0% + 0.05Ω)	JIS-C-5201-1 4.18 IEC-60115-1 4.18 260 ± 5°C for 10 seconds
Voltage Proof	No breakdown or flashover		JIS-C-5201-1 4.7 IEC-60115-1 4.7 1.42 times Max. Operating Voltage for 1 minute
Leaching	Individual leaching area ≤5% Total leaching area ≤10%		JIS-C-5201-1 4.18 IEC-60068-2-58 8.2.1 260 ± 5°C for 30 seconds
Rapid Change of Temperature	±(0.5% + 0.05Ω)	±(1.0% + 0.05Ω)	JIS-C-5201-1 4.19 IEC-60115-1 4.19 -55°C to +155°C, 5 cycles

RCWV (Rated continuous working voltage) - $\sqrt{(P^*R)}$ or Max Operating voltage whichever is lower

- Storage Temperature: 25 ± 3°C; Humidity < 80%RH



■ SOLDERING CONDITION

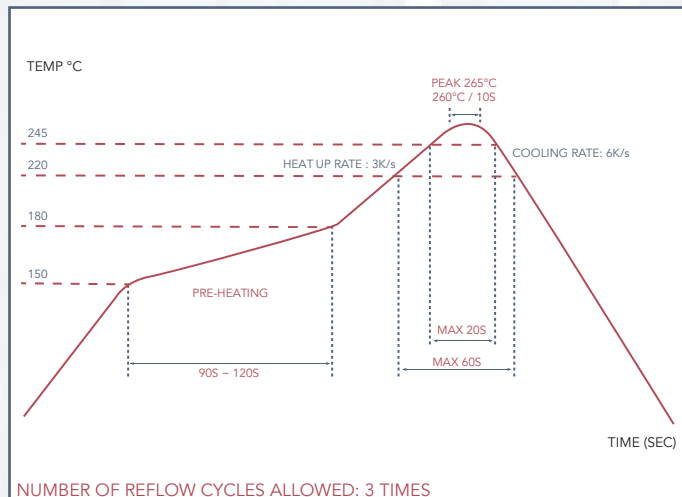

IR REFLOW SOLDERING

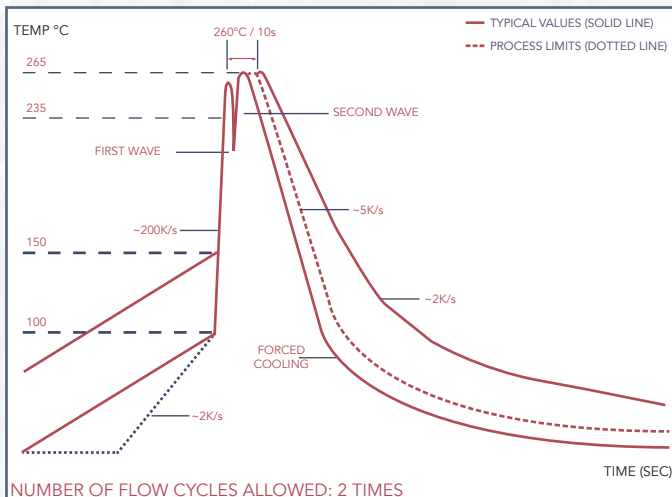

WAVE SOLDERING (FLOW SOLDERING)

- (1) Time of IR reflow soldering at maximum temperature point 260°C : 10s
- (2) Time of wave soldering at maximum temperature point 260°C : 10s
- (3) Time of soldering iron at maximum temperature point 410°C : 5s

■ PACKAGING

- Packaging Quantity & Reel Specifications

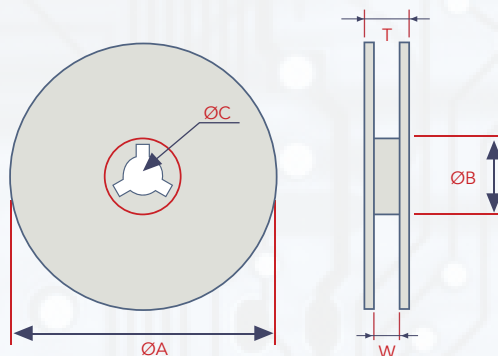

TYPE	PACKAGING QUANTITY		TAPE WIDTH	REEL DIAMETER	ØA	ØB	ØC	W	T				
RST04	Paper	10K	8mm	7 inch	178.5 ± 1.5	60 ^{+1/0}	13.0 ± 0.2	9.0 ± 0.5	12.5 ± 0.5				
RST06	Paper	5K											
RST10		10K								10 inch	254 ± 1.0	100 + 0.5	13.5 ± 0.5
RST12													
RST14	Embossed	4K	12mm	7 inch	178.5 ± 1.5	60 ^{+1/0}	13.0 ± 0.5	15.0 ± 0.5					
RST20													
RST25													

PACKAGING

- Paper Tape Specifications

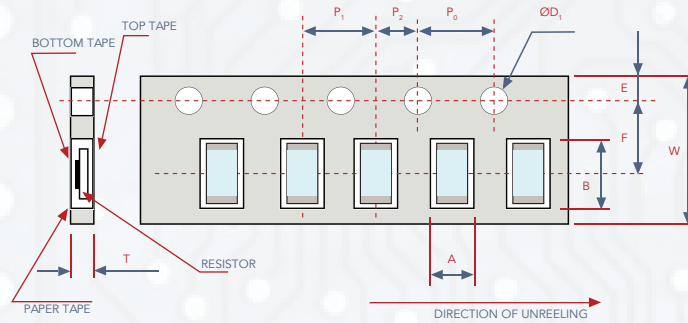

TYPE	A	B	W	E	F	P ₀	P ₁	P ₂	ØD ₀	T
RST04	0.65 ± 0.10	1.15 ± 0.10	8.0 ± 0.20	1.75 ± 0.10	3.50 ± 0.05	4.00 ± 0.10	2.00 ± 0.05	2.00 ± 0.05	1.50 +0.1, -0	0.45 ± 0.10
RST06	1.10 ± 0.10	1.90 ± 0.10					0.70 ± 0.10			
RST10	1.60 ± 0.10	2.40 ± 0.20	3.50 ± 0.20	1.75 ± 0.10	3.50 ± 0.05	4.00 ± 0.10	4.00 ± 0.05	2.00 ± 0.05	1.50 +0.1, -0	0.85 ± 0.10
RST12	1.90 ± 0.10									
RST14	2.90 ± 0.10									

- Embossed Plastic Tape Specifications

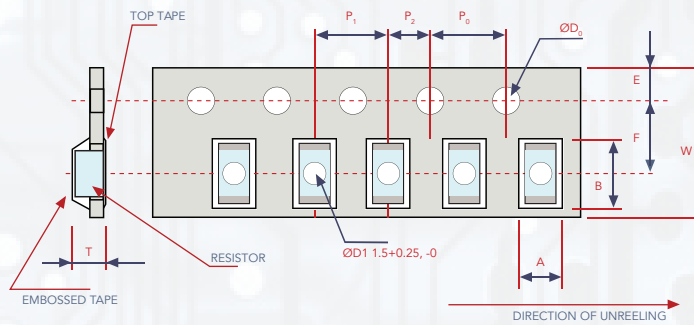

TYPE	A	B	W	E	F	P ₀	P ₁	P ₂	ØD ₀	T
RST20	2.8 ± 0.10	5.5 ± 0.10	12.0 ± 0.30	1.75 ± 0.10	5.5 ± 0.05	4.00 ± 0.10	4.00 ± 0.10	2.00 ± 0.05	1.50 +0.1, -0	1.2 ^{±0}
RST25	3.5 ± 0.10	6.7 ± 0.10								

MARKING

- No Marking for 0401
- 1%, 5% for 0805 / 1206 / 1210 / 2010 / 2512: 4 digits marking

Example:

RESISTANCE	47mΩ	75mΩ	15mΩ	750mΩ	820mΩ
MARKING	R047	R075	R015	R750	R820

- 5% for 0603: 3 digits marking in E24
- 1% for 0602: 3 digits marking with under-line in E96 (non-including E24 series)



- 3 digit marking for E24 or R value suffix is zero in E96: R10 - 100mΩ ; R28 - 280mΩ

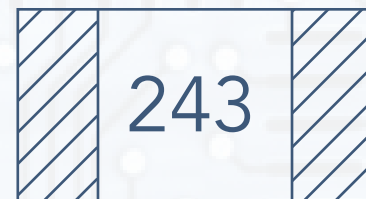

- 3 digit marking for E96: 243 - 243mΩ; 511 - 511mΩ

