

ANTI-CORROSIVE THIN FILM PRECISION CHIP RESISTOR

- RNC SERIES -

FEATURES

- Long term life stability and demonstrated the Anti-Corrosion claims
- Special passivated NiCr film for Anti-Acid and Anti-Damp
- Tight tolerance down to $\pm 0.1\%$
- Extremely low TCR down to ± 15 PPM/ $^{\circ}\text{C}$
- Wide resistance range 10 ohm ~ 1.5 Mega ohm



APPLICATIONS

- High-End Computer
- Industrial Equipment
- Automatic Equipment Controller
- Medical Equipment
- Telecommunication Device
- High-End Multimedia Electronics
- Outdoor Electronic Applications

DERATING CURVE

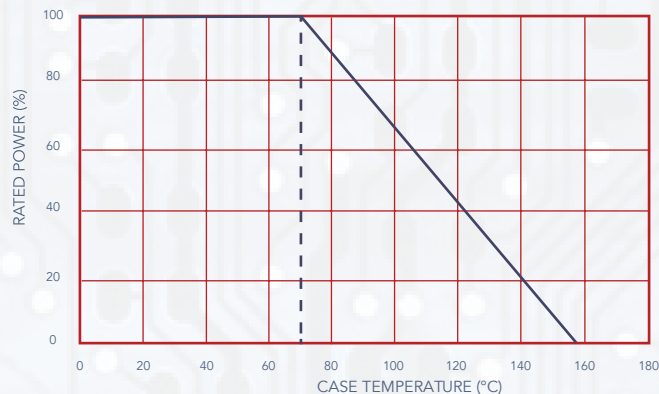

DIMENSIONS

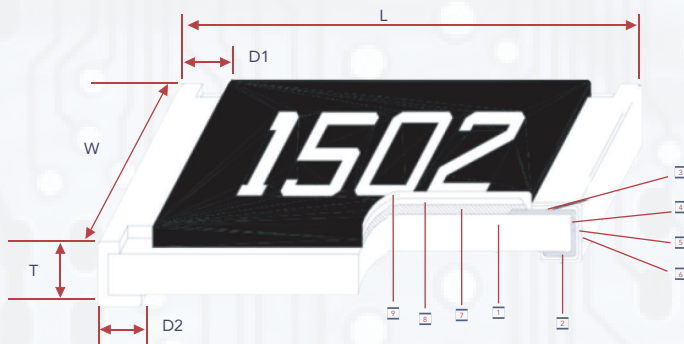

- | | | |
|-------------------------|---------------------------|------------------|
| 1 Alumina Substrate | 4 Edge Electrode (NiCr) | 7 Resistor Layer |
| 2 Bottom Electrode (Ag) | 5 Barrier Layer (Ni) | 8 Passivation |
| 3 Top Electrode (Ag-pd) | 6 External Electrode (Sn) | 9 Overcoat |

TYPE	SIZE (INCH)	L	W	T	D1	D2	WEIGHT (G) (1000PCS)
RNC04	0402	1.00±0.05	0.50±0.05	0.30±0.05	0.20±0.10	0.20±0.10	0.55
RNC06	0603	1.55±0.10	0.80±0.10	0.45±0.10	0.30±0.20	0.30±0.20	1.85
RNC10	0805	2.00±0.15	1.25±0.15	0.55±0.10		0.40±0.25	4.76
RNC12	1206	3.05±0.15	1.55±0.15		0.42±0.20	0.35±0.25	9.11
RNC20	2010	4.90±0.15	2.40±0.15		0.60±0.30	0.50±0.25	23.82
RNC25	2512	6.30±0.15	3.10±0.15				38.46

PART NUMBERING

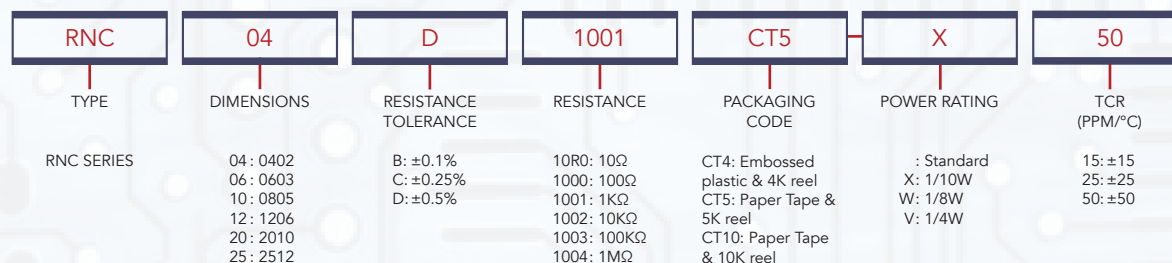

STANDARD ELECTRICAL SPECIFICATIONS

TYPE	ITEM	POWER RATING AT 70°C	OPERATING TEMP RANGE	MAX OPERATING VOLTAGE	MAX OVERLOAD VOLTAGE	RESISTANCE RANGE (mΩ)			T.C.R. (PPM / °C)
						±0.1%	±0.25%	±0.5%	
RNC04	0402	1/16W	-55~+155°C	25V	50V	49.9Ω - 12KΩ			±15
						24.9Ω - 2.49KΩ			±25 ±50
RNC06	0603	1/16W		50V	100V	24.9Ω - 332KΩ			±15 ±25 ±50
RNC10	0805	1/10W		100V	200V	10Ω - 1MΩ			±15 ±25 ±50
RNC12	1206	1/8W		150V	300V	10Ω - 1MΩ			±15 ±25 ±50
RNC20	2010	1/4W		150V	300V	24.9Ω - 1MΩ			±15
					10Ω - 1.5MΩ			±25 ±50	
RNC25	2512	1/2W	150V	300V	24.9Ω - 1MΩ			±15	
					10Ω - 1.5MΩ			±25 ±50	

HIGH POWER RATING ELECTRICAL SPECIFICATIONS

TYPE	ITEM	POWER RATING AT 70°C	OPERATING TEMP RANGE	MAX OPERATING VOLTAGE	MAX OVERLOAD VOLTAGE	RESISTANCE RANGE (mΩ)			T.C.R. (PPM / °C)
						±0.1%	±0.25%	±0.5%	
RNC06	0603	1/10W	-55~+155°C	75V	150V	24.9Ω - 220KΩ			±15 ±25 ±50
RNC10	0805	1/8W		150V	300V	24.9Ω - 680KΩ			±15 ±25 ±50
RNC12	1206	1/4W		200V	400V	24.9Ω - 1MΩ			±15 ±25 ±50

Operating Voltage - $\sqrt{(P \cdot R)}$; or Max operating voltage listed above, whichever is lower
 Overload Voltage - $2.5 \cdot \sqrt{(P \cdot R)}$ or Max operating voltage listed above, whichever is lower
 Cal-Chip is capable of manufacturing the optional spec based on customer's requirement.

ENVIRONMENTAL CHARACTERISTICS

ITEMS	REQUIREMENT		TEST METHOD
	SIZE 0603 0805 1206 2010 2512	SIZE 0402	
Short Time Overload	≤±0.02% ≤±0.2% for high power rating	≤±0.1%	JIS-C-5201-1 5.5 RCWV*2.5 or Max. overload voltage whichever is lower for 2 seconds
Endurance	≤±0.05% ≤±0.25% for high power rating	≤±0.25%	MIL-STD-202 METHOD 108A 70±2°C, RCWV for 1000 hrs with 1.5 hrs "ON" and 0.5 hrs "OFF"
Damp Heat with Load	≤±0.05% ≤±0.25% for high power rating	≤±0.5%	MIL-STD-202 METHOD 103B 40±2°C, 90~95% R.H., RCWV for 1000 hrs with 1.5 hrs "ON" and 0.5 hrs "OFF"
Bending Strength	95% Min coverage		MIL-STD-202 METHOD 208H 245±5°C for 3 seconds
Resistance to Soldering Heat	≤±0.02%	≤0.1%	MIL-STD-202 METHOD 210E 260±5°C for 10 seconds
Thermal Shock	≤±0.02	±0.1%	MIL-STD-202 METHOD 107G -55°C ~ 150°C, 100 cycles

RCWV (Rated continuous working voltage) - $\sqrt{(P \cdot R)}$; or Max operating voltage whichever is lower

- Storage Temperature: 25 ± 3°C; Humidity <80%RH



SOLDERING CONDITION

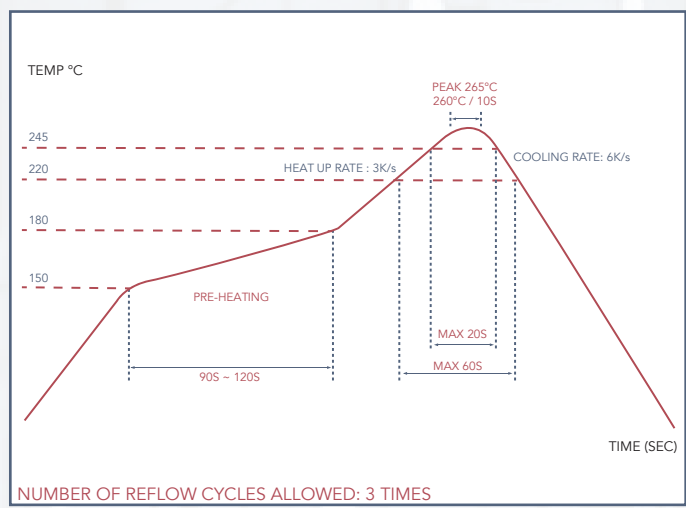

IR REFLOW SOLDERING

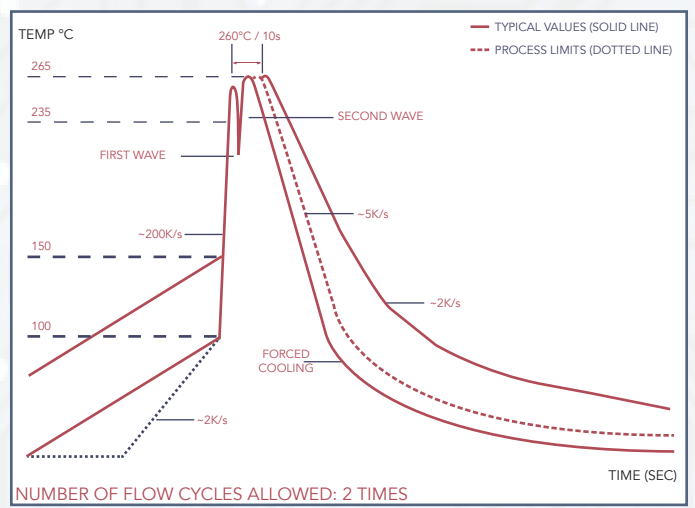

WAVE SOLDERING (FLOW SOLDERING)

- (1) Time of IR reflow soldering at maximum temperature point 260°C : 10s
- (2) Time of wave soldering at maximum temperature point 260°C : 10s
- (3) Time of soldering iron at maximum temperature point 410°C : 5s

PACKAGING

- Packaging Quantity & Reel Specifications

TYPE	ØA	ØB	ØC	W	T	UNIT: MM	
						PAPER TAPE (EA)	EMBOSSED PLASTIC TAPE (EA)
RNC04	178.0 ± 1.0	60.0 ± 1.0	13.5 ± 0.7	9.5 ± 0.1	11.5 ± 1.0	10,000	-
RNC06						5,000	-
RNC10						5,000	-
RNC12						5,000	-
RNC20						-	4,000
RNC25	13.5 ± 1.0	15.5 ± 1.0	-	-	4,000		

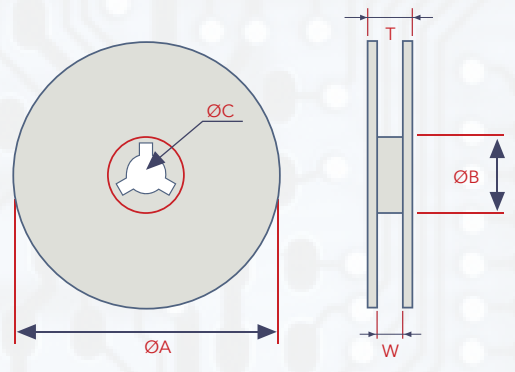

- Paper Tape Specifications

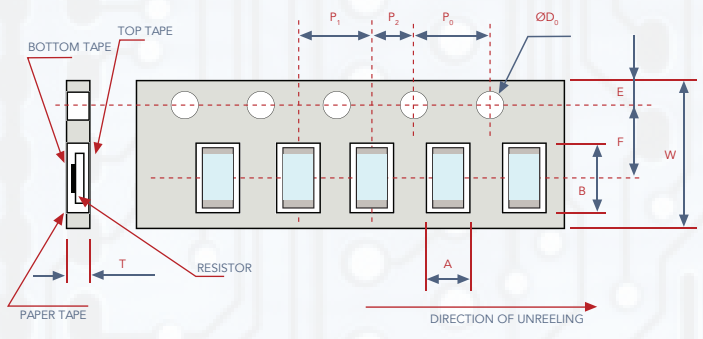

- Peel force of top cover tape
- The peel speed shall be about 300mm/min ±5%
- The peel force of top cover tape shall be between 8gf to 60gf

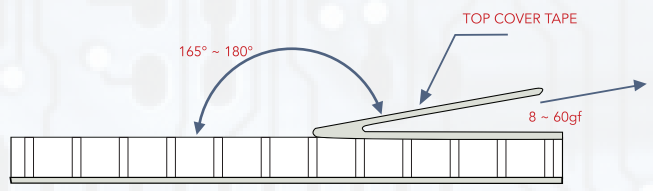

TYPE	A	B	W	E	F	P ₀	P ₁	P ₂	ØD ₀	T
										UNIT: MM
RNC04	0.70 ± 0.05	1.16 ± 0.05	8.0 ± 0.10	1.75 ± 0.05	3.50 ± 0.05	4.00 ± 0.10	4.00 ± 0.10	2.00 ± 0.05	1.55 ± 0.05	0.40 ± 0.03
RNC06	1.10 ± 0.05	1.90 ± 0.05								0.60 ± 0.03
RNC10	1.60 ± 0.10	2.37 ± 0.05								0.75 ± 0.05
RNC12	2.00 ± 0.05	3.55 ± 0.05	-	-	-	-	-	-	-	-

PACKAGING

- Embossed Plastic Tape Specifications

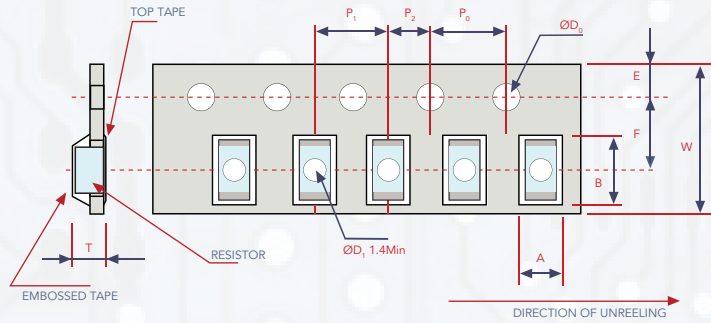

- Peel force of top cover tape
- The peel speed shall be about 300mm/min $\pm 5\%$
- The peel force of top cover tape shall be between 20gf to 80gf

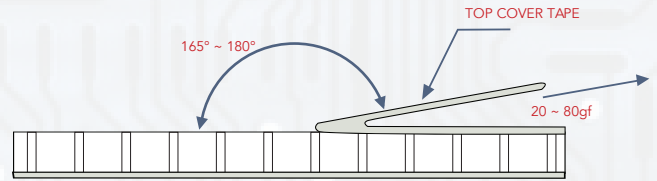

UNIT: MM

TYPE	A	B	W	E	F	P ₀	P ₁	P ₂	ØD ₀	T
RNC20	2.85 ± 0.10	5.45 ± 0.10	12.0 ± 0.10	1.75 ± 0.10	5.5 ± 0.05	4.00 ± 0.05	4.00 ± 0.10	2.00 ± 0.05	1.50 ± 0.10	1.00 ± 0.20
RNC25	3.40 ± 0.10	6.65 ± 0.10								

MARKING

- 0603 3 digit marking



- 3 digit marking for example:
 14C - 13K7Ω 13C - 13K3Ω
 68B - 4K99Ω 68X - 49.9Ω

CODE	E96	CODE	E96	CODE	E96	CODE	E96				
01	100	25	178	49	316	73	562				
02	102	26	182	50	324	74	576				
03	105	27	187	51	332	75	590				
04	107	28	191	52	340	76	604				
05	110	29	196	53	348	77	619				
06	113	30	200	54	357	78	634				
07	115	31	205	55	365	79	649				
08	118	32	210	56	374	80	665				
09	121	33	215	57	383	81	681				
10	124	34	221	58	392	82	698				
11	127	35	226	59	402	83	715				
12	130	36	232	60	412	84	732				
13	133	37	237	61	422	85	750				
14	137	38	243	62	432	86	768				
15	140	39	249	63	442	87	787				
16	143	40	255	64	453	88	806				
17	147	41	261	65	464	89	825				
18	150	42	267	66	475	90	845				
19	154	43	274	67	487	91	866				
20	158	44	280	68	499	92	887				
21	162	45	287	69	511	93	909				
22	165	46	294	70	523	94	931				
23	169	47	301	71	536	95	953				
24	174	48	309	72	549	96	976				
CODE	A	B	C	D	E	F	G	H	X	Y	Z
MULTIPLIER	10 ⁰	10 ¹	10 ²	10 ³	10 ⁴	10 ⁵	10 ⁶	10 ⁷	10 ⁻¹	10 ⁻²	10 ⁻³



MARKING

- 0603 3 digit marking for E24

Example: 101 - 100Ω
102 - 1KΩ

E24	10	11	12	13	15	16	18	20	22	24	27	30	33	36	39	43	47	51	56	62	68	75	82	91
-----	----	----	----	----	----	----	----	----	----	----	----	----	----	----	----	----	----	----	----	----	----	----	----	----

- 0805 ~ 2512 4 digit marking

Example:

RESISTANCE	100Ω	2.2KΩ	10KΩ	49.9KΩ	100KΩ
MARKING	1000	2201	1002	4992	1003

RECOMMEND LAND PATTERN

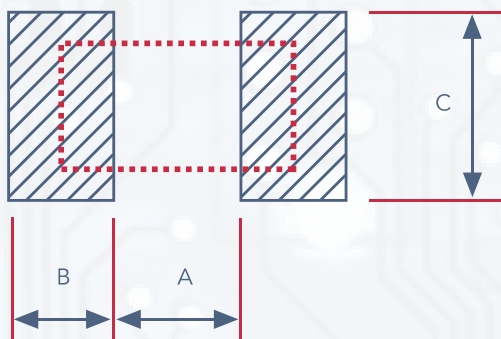

TYPE	A	B	C
RNC04	0.50	0.50	0.60 ± 0.2
RNC06	0.80	1.00	0.90 ± 0.2
RNC10	1.00	1.00	1.35 ± 0.2
RNC12	2.00	1.15	1.70 ± 0.2
RNC20	3.60	1.40	2.50 ± 0.2
RNC25	4.90	1.60	3.10 ± 0.2