

THIN FILM CURRENT SENSING CHIP RESISTOR

- RCS SERIES -

FEATURES

- Thin film process
- High power rating up to 3 Watts in 2512 size
- Tight tolerance down to $\pm 0.5\%$
- Extremely low TCR down to ± 50 PPM/ $^{\circ}\text{C}$
- Resistance values from 50m to 1ohm
- High purity alumina substrate for high power dissipation



APPLICATIONS

- Power Management Applications
- Switching Power Supply
- Over Current Protection in Audio Applications
- Voltage Regulation Module (VRM)
- DC-DC Converter, Battery Pack, Charger, Adaptor
- Automotive Engine Control
- Disk Driver
- Portable Devices (PDA, Cell Phone)

CONSTRUCTION

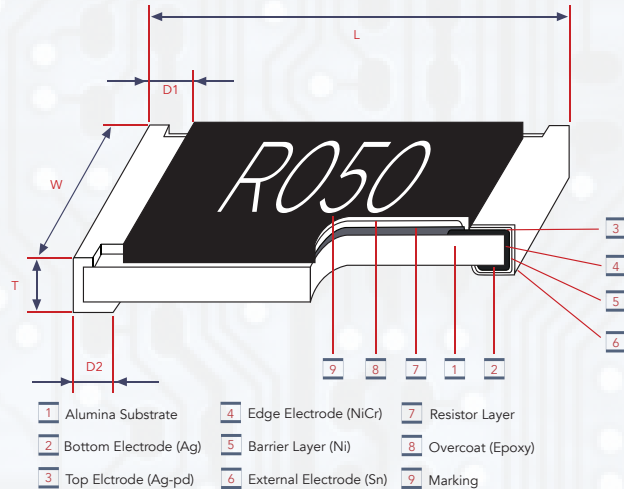

DERATING CURVE

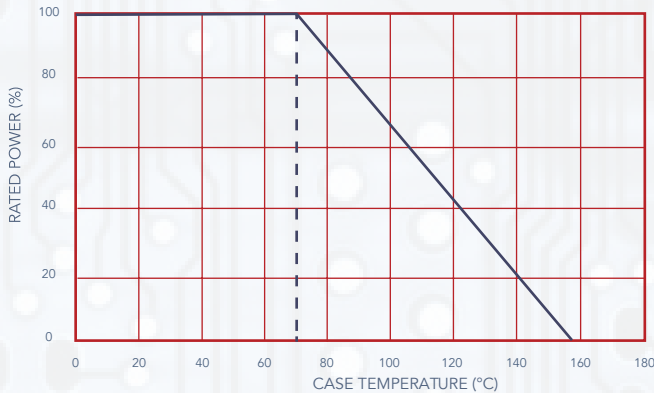

TYPE	SIZE (INCH)	L	W	T	D1	D2	WEIGHT (G) (1000PCS)
RCS04	0402	1.00±0.05	0.50±0.05	0.32±0.10	0.25±0.10	0.20±0.10	0.56
RCS06	0603	1.60±0.10	0.80±0.10	0.45±0.10	0.30±0.20	0.30±0.20	3.1
RCS10	0805	2.00±0.15	1.25±0.15	0.55±0.10		0.50±0.25	5.6
RCS12	1206	3.05±0.15	1.55±0.15	0.50±0.30	0.50±0.30	0.50±0.25	12.3
RCS20	2010	5.00±0.20	2.45±0.15	0.60±0.15	0.60±0.30	0.55±0.25	26.7
CRS25	2512	6.35±0.20	3.15±0.15	0.60±0.10			49.6

PART NUMBERING

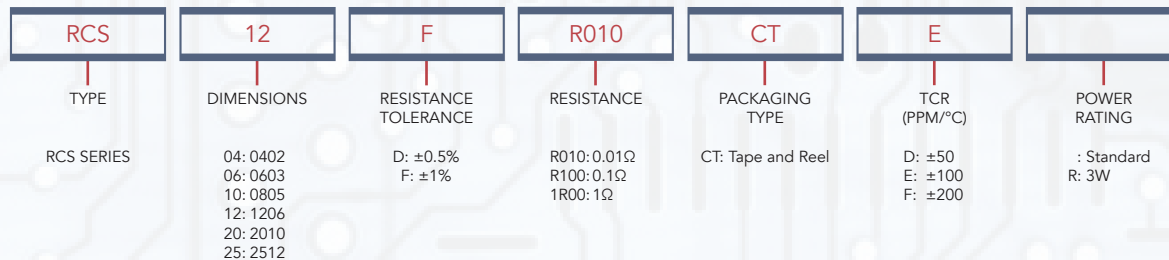

STANDARD ELECTRICAL SPECIFICATIONS

TYPE	ITEM	POWER RATING AT 70°C	OPERATING TEMP RANGE	RESISTANCE RANGE (mΩ)		T.C.R. (PPM / °C)
				±0.5%	±1%	
RCS04	0402	1/16W	-55~+155°C	500 - 1000		±100 ±50
RCS06	0603	1/10W		200 - 300 301 - 1000		
RCS10	0805	1/8W		-		
RCS12	1206	1/4W		50 - 100		±200 ±100 ±50
RCS20	2010	3/4W		101 - 300 301 - 1000		
RCS25	2512	1W		50 - 100 101 - 300 301 - 1000		

HIGH POWER RATING ELECTRICAL SPECIFICATION

TYPE	ITEM	POWER RATING AT 70°C	OPERATING TEMP RANGE	RESISTANCE RANGE (mΩ)	T.C.R. (PPM / °C)
				±1%	
RCS25	2512	3W	-55 ~ +155°C	100 - 1000	±100

Operating Voltage $\sqrt{P \cdot R}$; Overload Voltage $2.5 \cdot \sqrt{P \cdot R}$;
 Cal-Chip is capable of manufacturing the optional spec based on customer's requirement.

ENVIRONMENTAL CHARACTERISTICS

ITEMS	REQUIREMENT	TEST METHOD
Temperature Coefficient of Resistance (T.C.R.)	As Spec.	MIL-STD-202 METHOD 304 +25°C/-55/+25/+125/+25°C
Short Time Overload	±1%	JIS-C-5201-1 5.5 RCWV*2.5 or Max. overload voltage whichever is lower for 5 seconds
Insulation Resistance	≥1000MΩ	MIL-STD-202 METHOD 302 Apply 100V _{DC} for 1 minute
Endurance	±1%	MIL-STD-202 METHOD 302 70±2°C, RCWV for 1000 hrs with 1.5 hrs "ON" and 0.5 hrs "OFF"
Damp Heat with Load	±0.5%	MIL-STD-202 METHOD 103B 40±2°C, 90~95% R.H., RCWV for 1000 hrs with 1.5 hrs "ON" and 0.5 hrs "OFF"
Bending Strength	As Spec.	JIS-C-5201-1 6.1.4 Bending amplitude 3mm for 10 seconds
Solderability	95% coverage Min.	MIL-STD-202 METHOD 208H 245±5°C for 3 seconds
Resistance to Soldering Heat	0.5%	MIL-STD-202 METHOD 210E 260±5°C for 10 seconds
Dielectric Withstand Voltage	By Type	MIL-STD-202 METHOD 301 Apply Max. Overload Voltage for 1 minute
Thermal Shock	±0.5%	MIL-STD-202 METHOD 107G -55°C ~150°C, 100 cycles
Low Temperature Operation	±0.5%	JIS-C-5201-1 7.1 1 hour, -65°C followed by 45 minutes of RCWV



- Packaging Quantity & Reel Specifications

UNIT: MM

TYPE	ØA	ØB	ØC	W	T	PAPER TAPE (EA)	EMBOSSED PLASTIC TAPE (EA)
RCS04	178.0 ± 0.1	60.0 ± 1.0	13.5 ± 0.8	9.5 ± 1.0	11.5 ± 1.0	10,000	-
RCS06						-	
RCS10						-	
RCS12				-			
RCS20				-	-		
RCS25	-	-	-	13.5 ± 1.0	15.5 ± 1.0	-	4,000

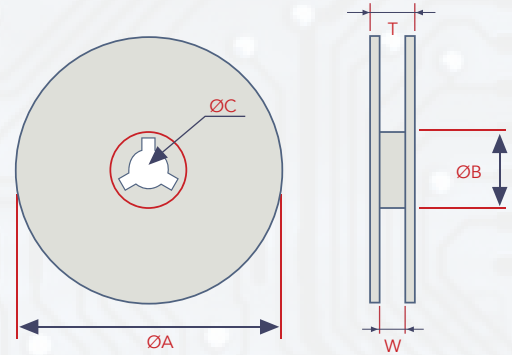

- Paper Tape Specifications

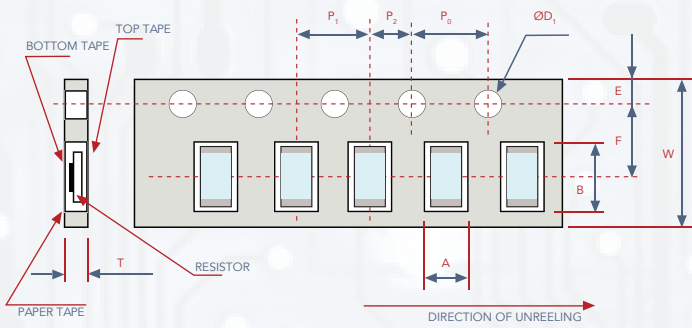

Peel force of top to cover tape
 The peel speed shall be about 300mm/min±5%
 The peel force of top cover tape shall be between 10 to 100g

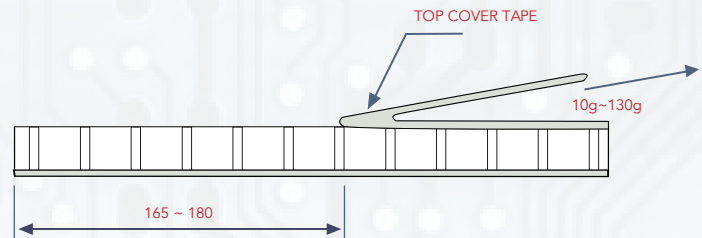

TYPE	A	B	W	E	F	P ₀	P ₁	P ₂	ØD ₀	T
RCS04	0.70 ± 0.05	1.16 ± 0.05	8.0 ± 0.10	1.75 ± 0.05	3.50 ± 0.05	4.00 ± 0.10	2.00 ± 0.05	2.00 ± 0.05	1.50 ± 0.05	0.40 ± 0.03
RCS06	1.10 ± 0.05	1.90 ± 0.05								0.60 ± 0.03
RCS10	1.60 ± 0.05	2.37 ± 0.05					0.75 ± 0.05			
RCS12	2.00 ± 0.05	3.55 ± 0.05	-	-	-	-	-	-	-	-

- Embossed Plastic Tape Specifications

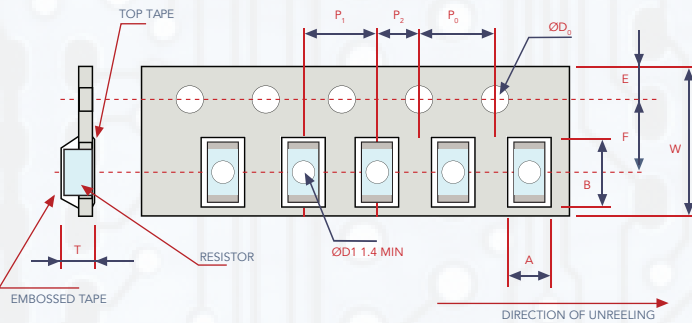

Peel force of top to cover tape
 The peel speed shall be about 300mm/min±5%
 The peel force of top cover tape shall be between 10 to 100g

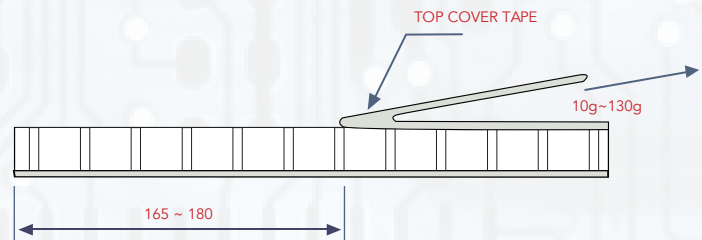

TYPE	A	B	W	E	F	P ₀	P ₁	P ₂	ØD ₀	T
RCS20	2.85 ± 0.10	5.45 ± 0.10	12.0 ± 0.10	1.75 ± 0.10	5.5 ± 0.05	4.00 ± 0.05	4.00 ± 0.10	2.00 ± 0.05	1.50 ± 0.10	1.00 ± 0.20
RCS25	3.40 ± 0.10	6.65 ± 0.10								

REFLOW

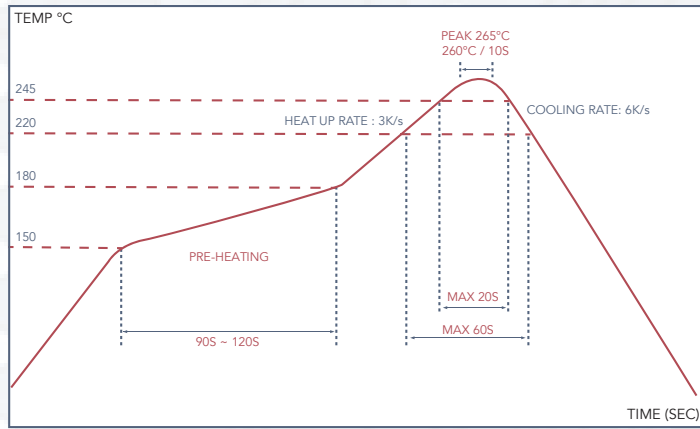

MARKING

- 0402 - No marking
- 0603 - 3 digit marking

Example

RESISTANCE	1Ω	0.1Ω	0.15Ω	0.01Ω	0.101Ω	0.035Ω
CODES	1R0	R10	R15	R01	101	035

- 0802 - 2512 - 4 digit marking

Example

RESISTANCE	1Ω	0.1Ω	0.05Ω	0.015Ω	0.01Ω
CODES	1R00	R100	R050	R015	R010

RECOMMEND LAND PATTERN

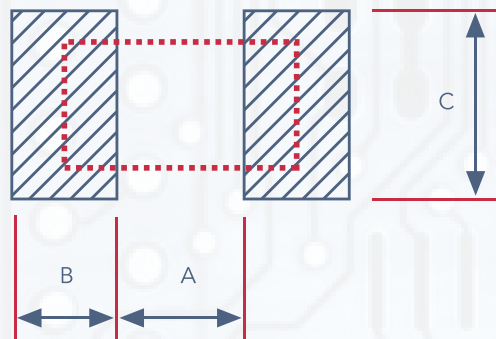

TYPE	A	B	C
RCS04	0.50	0.50	0.60 ± 0.2
RCS06	0.80	1.00	0.90 ± 0.2
RCS10	1.00	1.00	1.35 ± 0.2
RCS12	2.00	1.15	1.70 ± 0.2
RCS20	3.60	1.40	2.50 ± 0.2
RCS25	4.90	1.60	3.10 ± 0.2

