

PRODUCT IDENTIFICATION

- PRODUCT NAME Capacitor (MLCC)
- SERIES GMX31
- SIZE 1206
- DIELECTRIC X7R
- WEIGHT 34.79 mg
- MANUFACTURE NAME Cal-Chip Electronics Inc.
- ADDRESS 59 Steamwhistle Drive Ivyland, PA 18974

GENERAL COMPOSITION

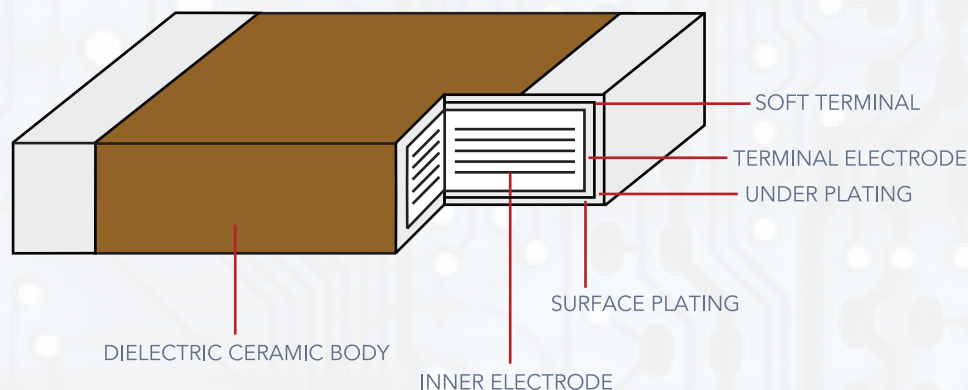

COMPOSITION OF PARTS		MATERIAL					CLASSIFICATION	EXEMPTION	TYPICAL WEIGHT		
MATERIAL NAME	TYPICAL WT% IN PRODUCT	SUBSTANCE NAME	TYPICAL WT% IN PRODUCT	SUBSTANCE NAME	TYPICAL WT% IN PRODUCT	CAS NO.	USE/PURPOSE OF MATERIAL		SUBSTANCE WEIGHT (mg)	MATERIAL WEIGHT (mg)	PRODUCT WEIGHT (mg)
Dielectric Ceramic Body	86.05	Barium Titanate	98	Barium Titanate (IV)	84.3290	12047-27-7	Dielectric Body	29.338	29.937	34.79	
		Yttrium Oxide	2	Yttrium Oxide	1.7210	1314-36-9		0.599			
Inner Electrode	2.85	Nickel	80	Nickel	2.2800	7440-02-0	Inner Electrode	0.793	0.991		
		Barium Titanate	20	Barium Titanate (IV)	0.5700	12047-27-7		0.198			
Terminal Electrode	1.90	Copper	88	Copper	1.6720	7440-50-8	Terminal Electrode	0.582	0.661		
		Lead Free Glass	12	Lead Free Glass Frit	0.2280	65997-18-4		0.079			
Soft Terminal	3.30	Silver	85	Silver	2.8050	7440-22-4	Soft Terminal	0.976	1.148		
		Phenolic Epoxy Resin	10	Phenolic Epoxy Resin	0.3300	9003-36-5		0.115			
		Phenolic Resin	5	Phenolic Resin	0.1650	9003-35-4		0.057			
Under Plating	3.54	Nickel	100	Ni	3.5400	7440-02-0	Plating	1.232	1.232		
Surface Plating	2.36	Matte Sn	100	Matte Sn	2.3600	7440-31-5	Plating	0.821	0.821		