

THICK FILM CHIP RESISTOR - ANTI SURGE

- CWR SERIES -



SCOPE

- This specification for approval relates to Anti-Surge Thick Film Chip Resistors (Lead Free) manufactured by Cal-Chip Electronics, Inc. The test items follow the test standard of AEC-Q200 Grade 4.

TYPE DESIGNATION

- The type designation shall be in the following form:

TYPE	POWER RATING	RESISTANCE TOLERANCE	NOMINAL RESISTANCE
CWR06 (0603)	1/4W	J, K, M	10Ω

PART NUMBERING

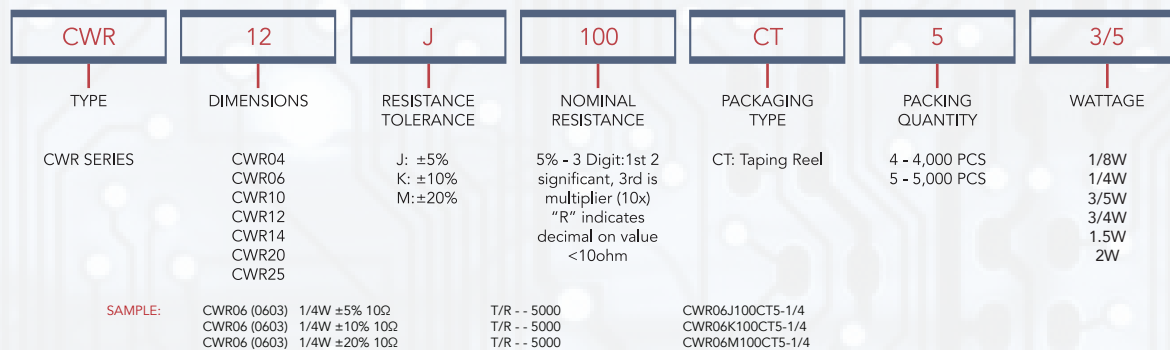

RATINGS

TYPE	CWR04 (0402)	CWR06 (0603)	CWR10 (0805)	CWR12 (1206)	CWR14 (1210)	CWR20 (2010)	CWR25 (2512)
POWER RATING	1/8W	1/4W	1/2W	3/5W	3/4W	1.5W	2W
MAX. WORKING VOLTAGE	50 V	75 V	150 V	200 V	200 V	400 V	500 V
MAX OVERLOAD VOLTAGE	100 V	150 V	300 V	400 V	500 V	800 V	1000 V
DIELECTRIC WITHSTANDING VOLTAGE	100 V	300 V	500 V	500 V	500 V	500 V	500 V
TEMPERATURE RANGE	-55°C ~ +155°C						
AMBIENT TEMPERATURE	70°C						

NOMINAL RESISTANCE

- Effective figures of nominal resistance shall be in accordance :
E-24 values – these are preferred and will have standard MOQ

VOLTAGE RATING

- Resistors shall have a rated direct-current (DC) continuous working voltage or an approximate sine-wave root-mean-square (RMS) alternating-current (AC) continuous working voltage at commercial line frequency and waveform corresponding to the power rating , as determined from the following formula:

$$RCWV = \sqrt{P \times R}$$

Note : Max. Working Voltage or $\sqrt{P \times R}$ whichever is lesser
Max. Overload Voltage or $2.5 \sqrt{P \times R}$ whichever is lesser

Where: RCWV = Rated DC or RMS AC continuous working voltage at commercial-line frequency and waveform (volt)

P = Power Rating (watt)

R = Nominal Resistance (ohm)

CONSTRUCTION & DIMENSIONS

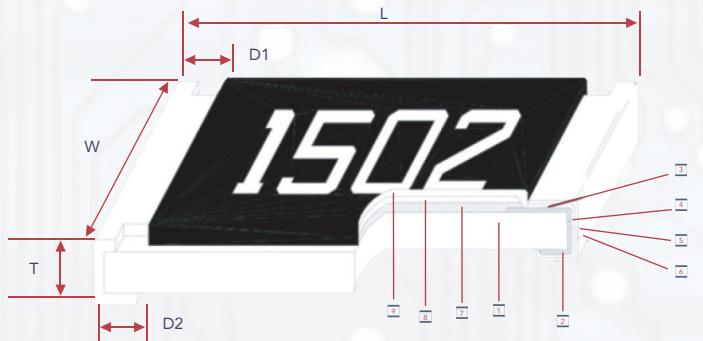

- | | | |
|-------------------------|---------------------------|------------------------------|
| 1 Alumina Substrate | 4 Edge Electrode (NiCr) | 7 Resistor Layer (Ag/Pd) |
| 2 Bottom Electrode (Ag) | 5 Barrier Layer (Ni) | 8 Primary Overcoat (Glass) |
| 3 Top Electrode (Ag-pd) | 6 External Electrode (Sn) | 9 Secondary Overcoat (Epoxy) |

TYPE	DIMENSION (MM)				
	L	W	H	ℓ1	ℓ2
CWR04 (0402)	1.00 ± 0.10	0.50 ± 0.05	0.35 ± 0.05	0.20 ± 0.10	0.25 ± 0.10
CWR06 (0603)	1.60 ± 0.10	0.80 ± 0.10	0.45 ± 0.10	0.30 ± 0.20	0.30 ± 0.20
CWR10 (0805)	2.00 ± 0.15	1.25 + 0.15 - 0.10	0.55 ± 0.10	0.40 ± 0.20	0.40 ± 0.20
CWR12 (1206)	3.10 ± 0.15	1.55 + 0.15 - 0.10		0.45 ± 0.20	0.45 ± 0.20
CWR14 (1210)	3.10 ± 0.10	2.60 ± 0.20		0.50 ± 0.25	0.50 ± 0.20
CWR20 (2010)	5.00 ± 0.10	2.50 ± 0.20		0.60 ± 0.25	
CWR25 (2512)	6.35 ± 0.10	3.20 ± 0.20			

POWER RATING AND DIMENSIONS

- Power rating: Resistors shall have a power rating based on continuous load operation at an ambient temperature of 70°. For temperature in excess of 70°C , The load shall be derated as shown in figure 1.

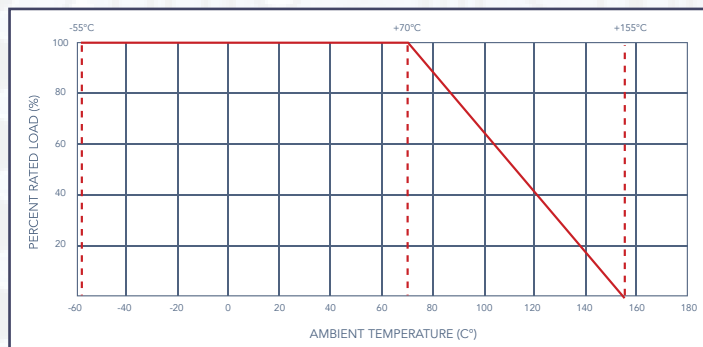

TYPE	POWER RATING AT 70°C	TOLERANCE %	RESISTANCE RANGE	STANDARD SERIES
CWR04	1/8 W	±5% ±10% ±20%	1Ω ~ 10MΩ	E-24
CWR06	1/4 W			
CWR10	1/2 W			
CWR12	3/5 W			
CWR14	3/4 W			
CWR20	1.5 W			
CWR25	2W			



CURVE OF PULSE DURATION

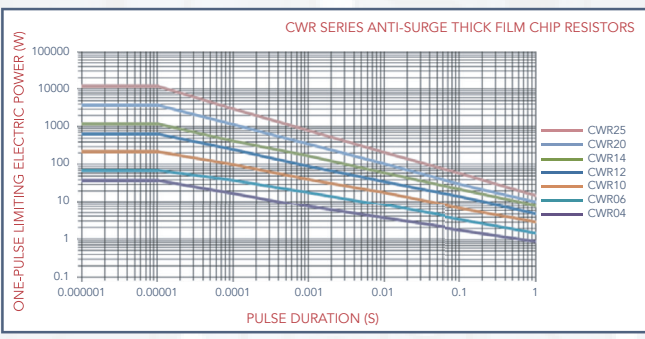

MARKING

- RESISTORS

Marking for E-24 series in CWR06, CWR10, CWR12, CWR14. CWR20, CWR25 size : 3 Digits

*The first two digits are significant figures of resistance and the third digit denoted number of zeros

Example: 33K Ω



*For ohmic values below 10 Ω , letter "R" is for decimal point.

Example: 2.2K Ω



Chip Resistors type CWR 0 No marking

LIGHTNING SURGE

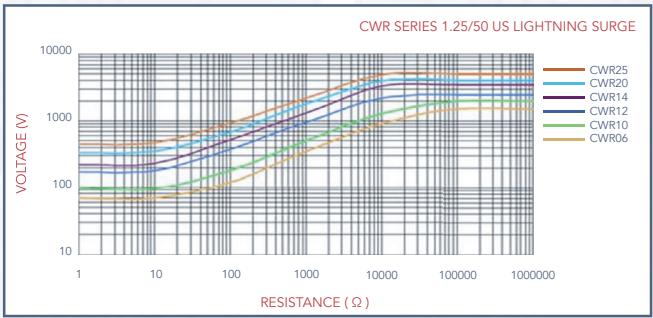

PULSE VOLTAGE LIMIT

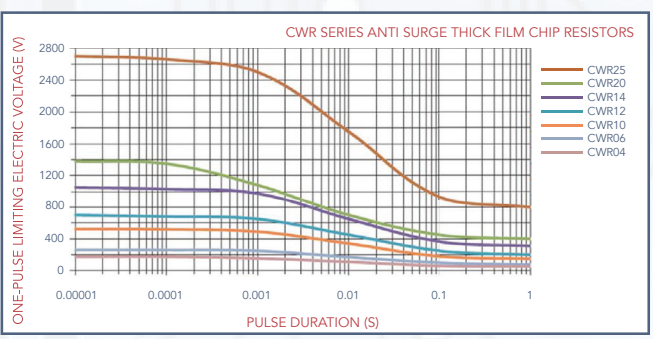

- Label shall be marked with the following item:

- A. Part No.
- B. Quantity
- C. Date Code
- D. Lot No.

PERFORMANCE SPECIFICATION

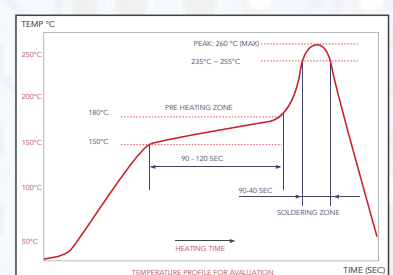
Anti-Surge Thick Film Chip Resistors (Lead Free) AEC-Q200 Compliant		
CHARACTERISTICS	LIMITS	TEST METHODS
Operational Life	$\pm (3.0\% + 0.1 \Omega)$ Max.	125°C, at 35% of operating power, 1000H (1.5 hours "ON", 0.5 hour "OFF") (MIL-STD-202 Method 108)
Temperature Coefficient of Resistance	1 Ω ~ 10 Ω : ± 400 PPM/°C 10.1 Ω ~ 10M Ω : ± 100 PPM/°C	Natural resistance change per temp. degree centigrade. $\frac{R2-R1}{R1 (t2-t1)} \times 10^6 \text{ (PPM/°C)}$ R1: Resistance value at room temperature (T1) R2: Resistance value at room temp. plus 100°C (T2) Test pattern: room temp. (T1), room temp. +100°C (T2)
External Visual	No Mechanical Damage	Electrical test not required. Inspect device construction, marking and workmanship (MIL-STD-883 Method 2009)
Physical Dimension	Reference 2.0 Dimension Standards	Verify physical dimensions to the applicable device detail specification. Note: User(s) and Suppliers spec. Electrical test not required. (JESD22 MH Method JB-100)
Resistance to Solvent	Marking Unsmearred	Note: Add Aqueous wash chemical – OKEM Clean or equivalent. Do not use banned solvents. (MIL-STD-202 Method 215)
Terminal Strength	Not broken	Force of 1.8kg for 60 seconds. (MIL-STD-202 Method 213)
High Temperature Exposure (Storage)	$\pm (1.0\% + 0.1 \Omega)$ Max.	1000hrs. at T=155°C. Unpowered. Measurement at 24 \pm 2 hours after test conclusion. (MIL-STD-202 Method 108)
Temperature cycling	$\pm (1.0\%+0.1\Omega)$ Max.	1000 Cycles (-55°C to +155°C). Measurement at 24 \pm 2 hours after test conclusion. (JESD22 Method JA-104)
Solderability	95% coverage Min.	For both leaded & SMD. Electrical test not required. Magnification 50X. Conditions: (J-STD-002)
Soldering Temperature Reference	Electrical characteristics shall be satisfied. Without distinct deformation in appearance. (95 % coverage Min.)	Wave soldering condition: (2 cycles Max.) Pre-heat : 100 ~ 120°C, 30 \pm 5 sec. Suggestion solder temp.: 235 ~ 255°C 10 sec. (Max.) Peak temp.: 260°C Reflow soldering condition: (2 cycles Max.) Pre-heat : 150 ~ 180°C, 90 ~ 120 sec. Suggestion solder temp.: 235 ~ 255°C, 20 ~ 40 sec. Peak temp.: 260°C  The graph shows a temperature profile for reflow soldering. The y-axis is Temperature in °C (50 to 250) and the x-axis is Time in seconds. The profile starts at 50°C, rises to 150°C (90-120 sec), then to 180°C (90-120 sec), then to a peak of 260°C (90-40 sec), and finally cools down. Key zones are labeled: PRE HEATING ZONE (150°C), HEATING TIME (150°C to 180°C), SOLDERING ZONE (180°C to 260°C), and COOLING ZONE (260°C to 235°C). A note indicates the peak is 260°C (MAX) and the temperature range is 235°C - 255°C.
Mechanical Shock	$\pm (1\%+0.1\Omega)$ max	Wave Form: Tolerance for half sine shock pulse. Peak value is 100g's. Normal duration (D) is 6. (MIL-STD-202 Method 213)
Vibration	$\pm (1\%+0.1\Omega)$ max	5g's for 20 min., 12cycle each of 3 orientations. Note: Use 8"*5"PCB. 031" thick 7 secure points (on one) long side and 2 secure points at corners of opposite sides. Parts mounted within 2' from any secure point. Test from 10-2000Hz. (MIL-STD-202 Method 204)
Biased Humidity	$\pm (3\%+0.1\Omega)$ Max.	10% rated power, 85°C/85%RH, 1000H, Measurement at 24 hours after test conclusion. (MIL-STD-202 Method 103)
ESD	$\pm (10\%+0.1\Omega)$ max	With the electrometer in direct contact with the discharge tip, verify the voltage setting at levels of $\pm 500V, \pm 1KV, \pm 2KV, \pm 4KV, \pm 8KV$, The electrometer reading shall be within $\pm 10\%$ for voltages from 500V to 800V. (AEC-Q200-002 or ISO/DIS 10605)



PERFORMANCE SPECIFICATION

Anti-Surge Thick Film Chip Resistors (Lead Free) AEC-Q200 Compliant		
CHARACTERISTICS	LIMITS	TEST METHODS
Flammability	No ignition of the tissue paper or scorching or the pinewood board	V-0 or V-1 are acceptable. Electrical test not required. (UL-94)
Board Flex	$\pm(1\%+0.05\Omega)\text{max}$	60 seconds minimum holding time. (JIS-C-6429)
Flame Retardance	No Flame	Temperature sensing at 500°C, Voltage power subjected to 32VDC current clamped up to 500ADC and decreased in 1.0VDC/hour. (AEC-Q200-001)
Resistance to Soldering Heat	$\pm(1\%+0.05\Omega)\text{max}$.	Condition B No PRE-HEAT of samples. Note: Single Wave Solder-Procedure 2 for SMD and Procedure 1 for Leaded with solder within 1.5mm of device body. (MIL-STD-202 Method 210)

* Sulfuration test: H2S 3-5PPM 50°C±2°C 91%~93%RH 1000H

PACKAGING

- Taping Dimension (MM)

- Embossed Taping

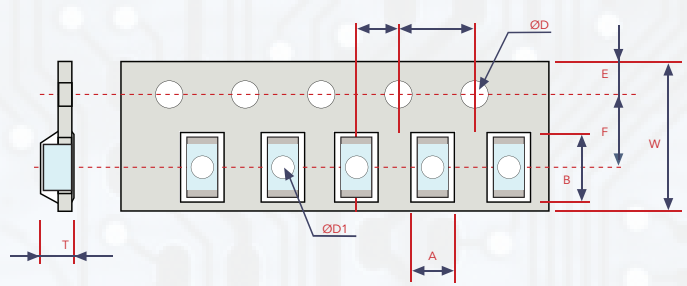
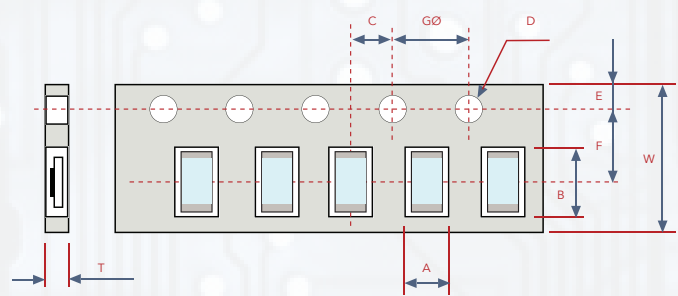

TYPE	A	B	C	ØD - 0	E	F	G	W	T
CWR04	0.65 ± 0.1	1.2 ± 0.1	2.00 ± 0.05	1.5 +0.1 -0	1.75 ± 0.1	3.50 ± 0.05	4.0 ± 0.1	8.0 ± 0.2	0.42 ± 0.05
CWR06	1.10 ± 0.2	1.9 ± 0.2							0.67 ± 0.1
CWR10	1.65 ± 0.2	2.4 ± 0.2							0.81 ± 0.1
CWR12	2.00 ± 0.2	3.6 ± 0.2							
CWR14	2.80 ± 0.2	3.5 ± 0.2							0.75 ± 0.1

TYPE	A ± 0.2	B ± 0.2	C ± 0.05	ØD + 0.1	E ± 0.1	F ± 0.05	G ± 0.1	W ± 0.2	ØD1	T
CWR20	2.90	5.60	2.0	1.5 +0.1 -0	1.75	5.5	4.0	12.0	1.5 +0.1 -0	1.0 ± 0.1
CWR25	3.50	6.70								

- Peeling Strength of Top Cover Tape
 - Test Condition: 0.1 to 0.7 N at a peel-off speed of 300mm / min

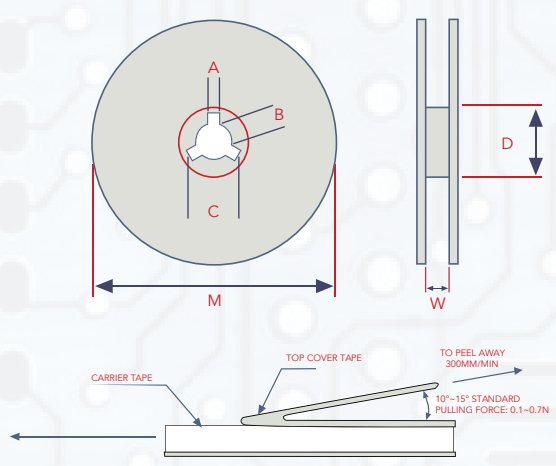

TYPE	PACKAGING	QTY PER REEL	A ± 0.5	B ± 0.5	C ± 0.5	D ± 1	M ± 2	W ± 1
CWR04	Paper	10,000 pcs	2	13	21	60	178	10
CWR06		5,000 pcs						
CWR10								
CWR12								
CWR14								
CWR20	Embossed	4,000 pcs						
CWR25			13.8					

■ ENVIRONMENT RELATED SUBSTANCE

This product complies to EU RoHS directive, EU PAHs directive, EU PFOS directive and Halogen free.

Ozone layer depleting substances.

Ozone depleting substances are not used in our manufacturing process of this product. This product is not manufactured using Chloro fluorocarbons (CFCs), Hydrochlorofluorocarbons (HCFCs), Hydrobromofluorocarbons (HBFCs) or other ozone depleting substances in any phase of the manufacturing process.

■ STORAGE CONDITION (MSL1)

The performance of these products, including the solderability, is guaranteed for a year from the date of arrival at your company, provided that they remain packed as they were when delivered and stored at a temperature of $25^{\circ}\text{C} \pm 10^{\circ}\text{C}$ and a relative humidity of $60\%RH \pm 10\%RH$, chemical and dust free atmosphere

Even within the above guarantee periods, do not store these products in the following conditions. Otherwise, their electrical performance and/or solderability may be deteriorated, and the packaging materials (e.g. taping materials) may be deformed or deteriorated, resulting in mounting failures.

1. In salty air or in air with a high concentration of corrosive gas, such as Cl_2 , H_2S , NH_3 , SO_2 , or NO_2
2. In direct sunlight

This production is used for automotive electronics, Cal-Chip Electronics will not be responsible for any damage, expense or loss caused by the use of this specification in any special environment. This series of product are suitable for automotive electronics applications, as show below, if there are other application, you need to confirm with Cal-Chip Electronics whether they are applicable:

- a. Control unit for informatiom, entertainment, navigation, audio;
- b. Control unit for comfortable doors, windows, seat;
- c. Control unit for internal lighting.

■ LEGAL DISCLAIMER

The information provided in the catalog/data sheet is for the purpose of describing product specifications only, and Cal-Chip Electronics and its affiliates (hereinafter collectively referred to as "Cal-Chip Electronics") hereby disclaim any liability for any errors, inaccuracies or incompleteness contained in any product-related information (including but not limited to product specifications, datasheets, pictures, graphics). Cal-Chip Electronics reserves the right to modify this content without prior notice. Thank you for your understanding.

Cal-Chip Electronics makes no representation, warranty, and guarantee as to the fitness of its products for any particular purpose or the continuing production of any Cal-Chip Electronics products.

To the maximum extent permitted by law, Cal-Chip Electronics disclaims

- (i) any and all liability arising out of the application or use of any Cal-Chip Electronics product,
- (ii) any and all liability, including without limitation special, consequential or incidental damages, and
- (iii) any and all implied warranties, including warranties of fitness for a particular purpose, non-infringement and merchantability.

Cal-Chip Electronics products are not intended for use in medical, life-saving, or life-sustaining equipment, nor are they intended for any other purpose where product failure or mismanagement could endanger life or cause harm to or death to the human body. Customers use or sell Cal-Chip Electronics products for the above purposes at their own risk. If need products for such purposes, please be sure to consult with our company to obtain relevant information about the applicable products.

Regardless of the application of Cal-Chip Electronics products, it is recommended to carry out safety tests while using measures such as protective circuits and redundant circuits to protect the safety of equipment.

