

THICK FILM CHIP RESISTOR ARRAYS

- CN SERIES -

FEATURES

- High density, more than 1 resistors in one small case
- Improvement of placement efficiency
- Tape/Reel packaging suitable for automatic placement machine
- Superior solderability

APPLICATIONS

- Master board
- CD & DVD Rom
- Hard Disk
- RAM

PART NUMBERING

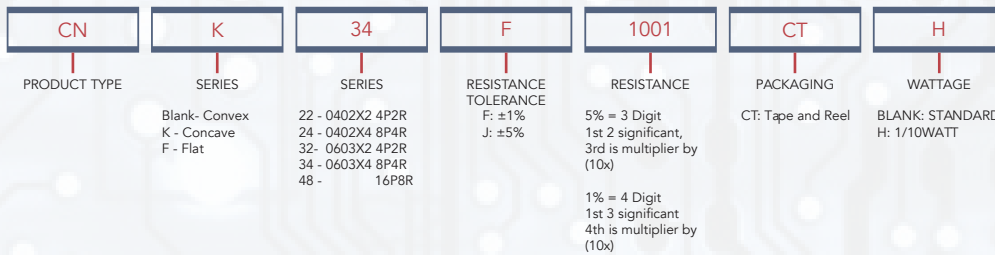

CONSTRUCTION

NO.	NAME
1	High Purity Alumina Substrate
2	Protective Covering
3	Resistive Covering
4	Termination Inner Ag/Pd
5	Termination Between Ni Plating
6	Termination Outer Sn Plating

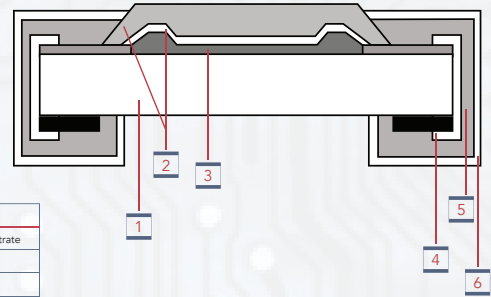

DERATIVE CURVE

- Resistors shall have a power rating based on continuous load operation at an ambient temperature of 70°C . For temperature in excess of 70°C
- The load shall be derate as shown.

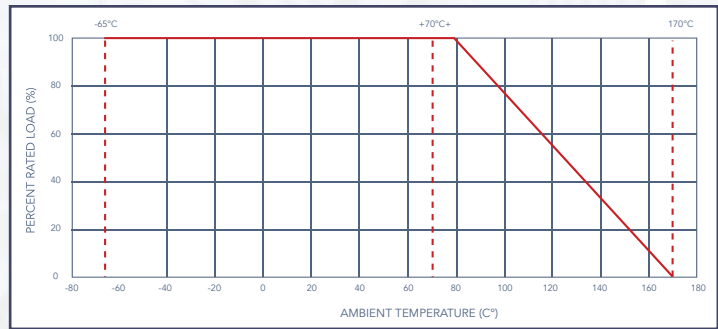

RATINGS

TYPE	POWER RATING	MAX WORKING VOLTAGE	MAX OVERLOAD VOLTAGE	DIELECTRIC WITHSTANDING VOLTAGE	RESISTANCE RANGE	TEMPERATURE COEFFICIENT PPM/°C	OPERATING TEMPERATURE	RESISTANCE VALUE OF JUMPER	RATED CURRENT OF JUMPER
					±5%, ±1%				
CN22	1/16W	50V	100V	100V	10Ω - 1MΩ	±200	-55°C ~ +155°C	<50MΩ	1A
CN24	1/16W								
CN32	1/16W								
CN34	1/16W			300V					
CN34---CTH	1/10W								
CN48	1/16W			100V					
CNK22	1/16W								
CNK24	1/16W	300V							
CNK34	1/10W								
CNF12	1/20W	12.5V	25V	/	/	±200	-55°C ~ +125°C		
CNF14	1/20W			/	/				

- Nominal Resistance - Effective figures of nominal resistance shall be in accordance:
E-24 values – these are preferred and will have standard MOQ
E-96 values – are available on case by case basis and availability and MOQ need to be confirmed with factory first
- Voltage rating - Resistors shall have a rated direct-current (DC) continuous working voltage or an approximate sine-wave root-mean-square (RMS) alternating-current (AC) continuous working voltage at commercial-line frequency and waveform corresponding to the power rating, as determined from the following formula:

$$RCWV = \sqrt{P \times R}$$

Note Max. Working Voltage or $\sqrt{P \times R}$ whichever is lesser
 Max. Overload Voltage or $2.5 \sqrt{P \times R}$ whichever is lesser

Where : RCWV = Rated DC or RMS AC continuous working voltage at commercial-line frequency and waveform (volt)
 P = Power Rating (watt) | R = Nominal Resistance (ohm)

DIMENSIONS IN MM

CN22 | CN32

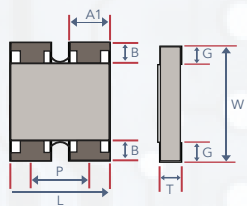

CN24 | CN34

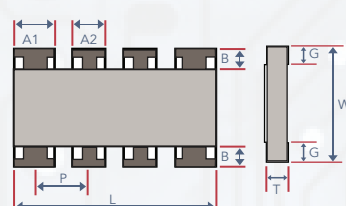

CN48

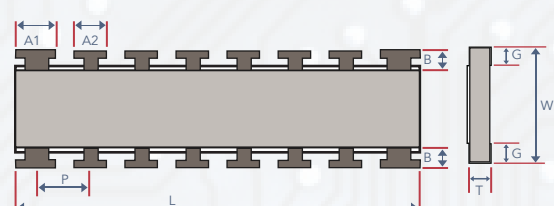

CNK22

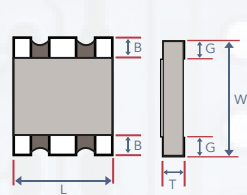

CNK24/CNK34

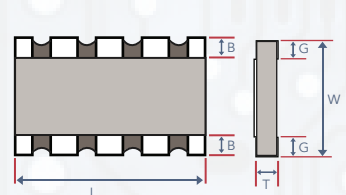

CNF12

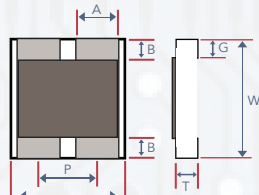

CNF14

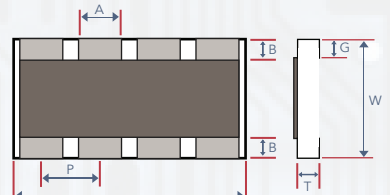

TYPE	SIZE INCH	L	W	T	A1	A2	B	P	G
CN22	0402*2	1.00±0.10	1.00±0.10	0.35 ± 0.10	0.33 ± 0.10	/	0.15 ± 0.05	0.65 ± 0.05	0.25 ± 0.10
CN24	0402*4	2.00 ± 0.10		0.45 ± 0.10	0.40 ± 0.05	0.30 ± 0.05	0.20 ± 0.15	0.50 ± 0.05	0.30 ± 0.15
CN32	0603*2	1.60 ± 0.15	1.60 ± 0.15	0.50 ± 0.10	0.60 ± 0.15	/	0.30 ± 0.10	0.80 ± 0.05	0.25 ± 0.10
CN34	0603*4	3.20 ± 0.20	1.60 ± 0.20		0.65 ± 0.15	0.50 ± 0.15	0.30 ± 0.15	0.80 ± 0.10	0.30 ± 0.15
CN48		4.00 ± 0.20	1.60 ± 0.15	0.45 ± 0.10	0.45 ± 0.05	0.30 ± 0.05	0.30 ± 0.15	0.50 ± 0.05	0.40 ± 0.15
CNK22	0402*2	1.00 ± 0.10	1.00 ± 0.10	0.35 ± 0.10	/	/	0.15 ± 0.10	/	0.30 ± 0.10
CNK24	0402*4	2.00 ± 0.10		0.45 ± 0.10	/	/	0.15 ± 0.10	/	0.30 ± 0.10
CNK34	0603*4	3.20 ± 0.20	1.60 ± 0.20	0.60 ± 0.10	/	/	0.30 ± 0.20	/	0.40 ± 0.10
CNF12	0201*2	0.80 ± 0.10	0.60 ± 0.10	0.35 ± 0.10	0.30 ± 0.10	/	0.15 ± 0.10	0.50 ± 0.05	0.15 ± 0.10
CNF14	0201*4	1.40 ± 0.10			0.20 ± 0.10	/		0.40 ± 0.05	

MARKINGS

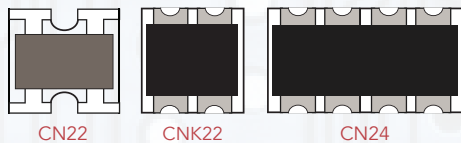

CN22 CNK22 CN24

- ±1% Tolerance of CN32, CN24, CN34, CNK34, and CN48 size: first three digits are significant figures of resistance and the fourth denotes number of zeros following

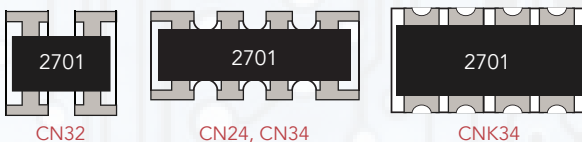

CN32 CN24, CN34 CNK34

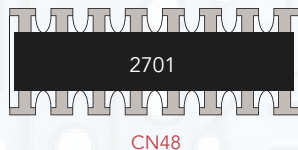

CN48

- Normal for CNF12 and CNF14 sizes, no marking on the body. 0Ω resistors is no marking too

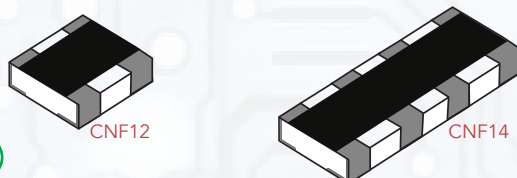

CNF12

CNF14

- ±5% Tolerance of CN24, CN32, CN34, CNK34 and CN48 size: the first two digits are significant figures of resistance and the third denotes number of zeros following

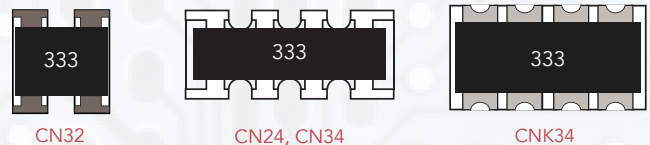

CN32

CN24, CN34

CNK34

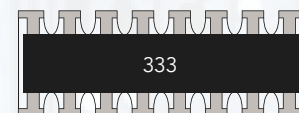

CN48

- Normal of CN32, CN24, CN34, CNK34 and CN48 size, the marking as following:

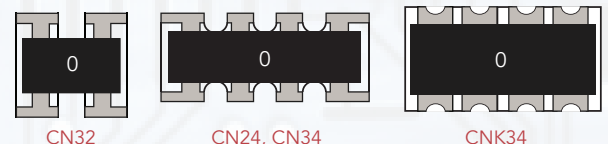

CN32

CN24, CN34

CNK34

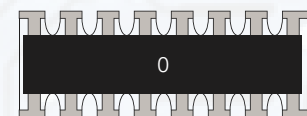

CN48



SOLDERING PAD SIZE RECOMMENDED

EQUIVALENT CIRCUIT DIAGRAM

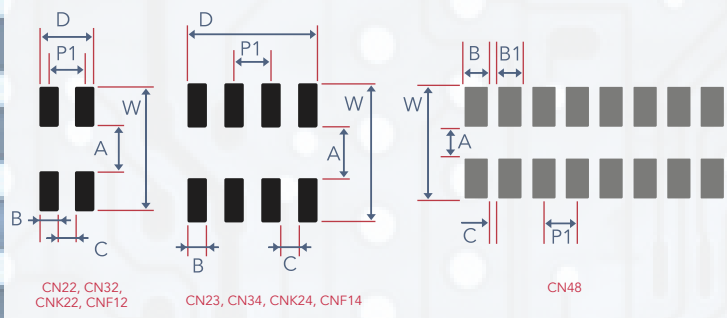

CN22 | CN32 | CNK22 | CNP12

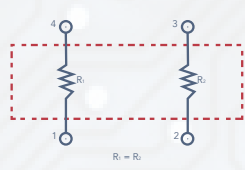

CN24 | CN34 | CNK24 | CNK34 | CNP14

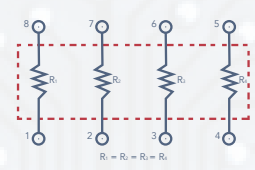

CN48

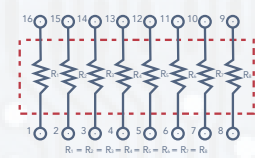

TYPE	DIMENSION (MM)							
	A	B	B1	B2	W	C	P1	D
CN22	0.5 ± 0.1	0.33 ± 0.1	/	/	2.0 ± 0.1	0.34 ± 0.1	/	1.0 ± 0.1
CN24	0.5 ± 0.1	0.3 ± 0.1	0.28 ± 0.1	0.28 ± 0.1	2.0 ± 0.1	0.22 ± 0.1	/	1.82 ± 0.1
CN32	0.8 ± 0.1	0.45 ± 0.05	/	/	2.6 ± 0.2	0.35 ± 0.05	0.80 ± 0.05	/
CN34/ CNF34	1.0 ± 0.1	0.4 ± 0.1	0.4 ± 0.1	0.4 ± 0.1	2.6 ± 0.1	0.40 ± 0.1	/	2.8 ± 0.1
CN48	1.0 ± 0.1	0.3 ± 0.1	0.3 ± 0.1	/	2.3 ± 0.1	0.20 ± 0.1	0.50 ± 0.1	/
CNK22	0.5 ± 0.1	0.3 ± 0.1	/	/	2.0 ± 0.1	0.20 ± 0.1	/	0.8 ± 0.1
CNK24	0.5 ± 0.1	0.3 ± 0.1	0.3 ± 0.1	0.3 ± 0.1	2.0 ± 0.1	0.20 ± 0.1	/	1.8 ± 0.1
CNK34	1.0 ± 0.1	0.4 ± 0.1	0.4 ± 0.1	0.4 ± 0.1	2.6 ± 0.1	0.40 ± 0.1	/	2.8 ± 0.1
CNF12	0.3 ± 0.1	0.3 ± 0.05	/	/	0.9 ± 0.2	0.20 ± 0.05	0.50 ± 0.05	/
CNF14	0.3 ± 0.1	0.2 ± 0.05	/	/	0.9 ± 0.2	0.20 ± 0.05	0.45 ± 0.05	/

SOLDERING CONDITIONS

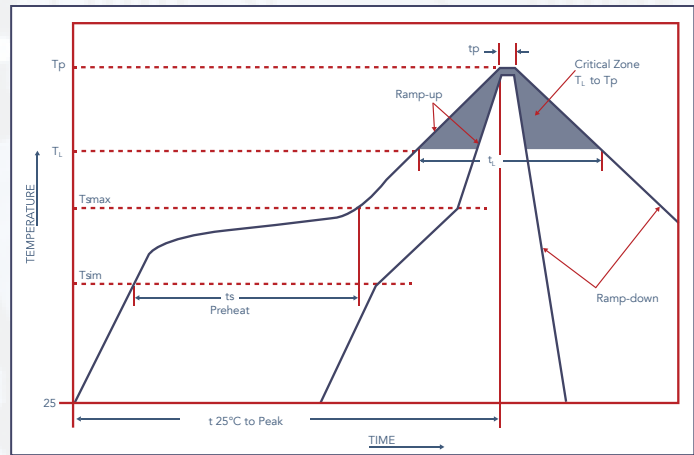

PROFILE FEATURE	LEAD (Pb) - FREE SOLDER
Preheat: Temperature Min ($T_{s_{min}}$) Temperature Max ($T_{s_{max}}$) Time ($T_{s_{min}}$ to $T_{s_{max}}$) (t_s)	150°C 200°C 60 - 120 seconds
Average ramp-up rate: ($T_{s_{max}}$ to T_p)	3°C / second max.
Time maintain above: Temperature (T_l) Time (t_l)	217°C 60 - 150 seconds
Peak Temperature (T_p)	260°C
Time Within +0/-5°C of Actual Peak Temperature (T_p) ²	10 seconds
Ramp Down Rate	6°C / second max.
Time 25°C to Peak Temperature	8 minutes max.

RECOMENDED WAVE SOLDERING

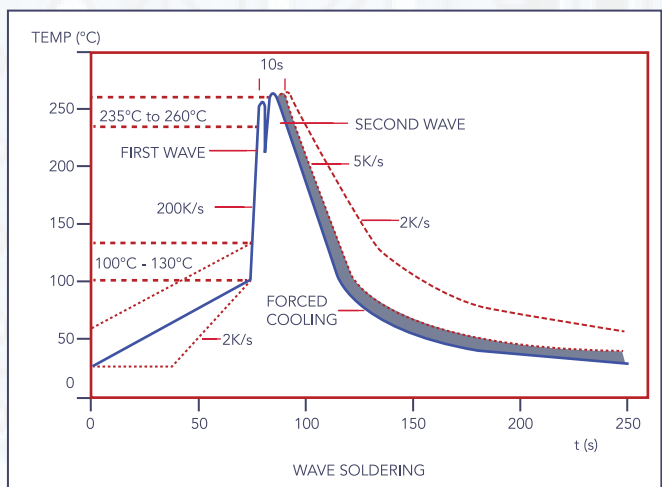

PERFORMANCE SPECIFICATION

CHARACTERISTICS	LIMITS	TEST METHODS (GB/T5729&JIS-C-5201&IEC60115-1)
TEMPERATURE COEFFICIENT	Reference 3.	4.8 Natural resistance changes per temp. Degree centigrade $\frac{R_2 - R_1}{R_1 (t_2 - t_1)} \times 10^6 \text{ (PPM/}^\circ\text{C)}$ R ₁ : Resistance Value at room temperature (t ₁); R ₂ : Resistance at test temperature (Upper limit temperature or Lower limit temperature) t ₁ : +25°C or specified room temperature t ₂ : Upper limit temperature or Lower limit temperature test temperature
*Short Time Overload	±(2.0% +0.1Ω) 2F01: 1% - ±1.0%+0.05Ω 5% - ±2.0%+0.05Ω *<50MΩ	4.13 Permanent resistance change after the application of 2.5 times RCWV for 5 seconds Apply max overload current for 0Ω
*Insulation Resistance	≥1,000MΩ	4.6 The measuring voltage shall be measured with a direct voltage of (100±15)V or a voltage equal to the dielectric withstanding voltage., and apply for 1 min
Terminal Bending	±(1.0% + 0.05Ω)	4.33 Twist of test board: Y/x = 3/90 mm for seconds
*Dielectric Withstanding Voltage	No evidence of flashover mechanical damage, arcing or insulation break down	4.7 Resistors shall be clamped in the trough of a 90°C metallic c-block and shall be tested at ac potential respectively specified in the given list of each product type for 60-70 seconds.
Soldering Heat	Resistance change rate is: ±(1.0% + 0.05Ω)Max	4.18 Dip the resistor into a solder bath having a temperature of 260°C ± 5°C and hold it for 10±1 seconds
*Solderability	Coverage must be over 95%	4.17 The area covered with a new, smooth, clean, shiny and continuous surface free from concentrated pinholes. Temperature of solder: 245±3°C; Dwell time in solder: 2~3 seconds
Rapid Change of Temperature	±(1.0% + 0.05Ω) 2F01: 1% - ±0.5%+0.05Ω 5% - ±1.0%+0.05Ω	4.19 30 min at lower limit temperature and 30 min at upper limit temperature, 100 cycles
*Load Life in Humidity	±(3.0% + 0.1Ω) 2F01: 1% - ±2.0%+0.1Ω 5% - ±3.0%+0.1Ω *<50mΩ	7.9 Resistance change after 1,000 hours (1.5 hours "on", 0.5 hour "off") at RCWV in a humidity chamber controlled at 40°C ± 2°C and 90 to 95% relative humidity Apply to rated current 0Ω
*Load Life	±(3.0% + 0.1Ω) 2F01: 1% - ±2.0%+0.1Ω 5% - ±3.0%+0.1Ω *<50mΩ	4.25.1 Permanent resistance change after 1,000 hours operating at RCWV, with cycle of (1.5 hours "on", 0.5 hour "off") at 70°C ± 2°C ambient Apply to rated current 0Ω
*Low Temperature Storage	±(3.0% + 0.1Ω) 2F01: 1% - ±2.0%+0.1Ω 5% - ±3.0%+0.1Ω *<50mΩ	IEC 60068-2-1 (Aa) Lower limit temperature, for 2H
*High Temperature Exposure	±(3.0% + 0.1Ω) 2F01: 1% - ±2.0%+0.1Ω 5% - ±3.0%+0.1Ω *<50mΩ	MIL-STD-002 108A Upper limit temperature, for 1000H
*Leaching	No visible damage	J-STD-002 Test D Samples completely immersed for 30 sec in solder bath at 260°C

The resistors of 0Ω only can do the characteristic noted of*

LABELS



CCE P/N CN34J000CT



Cust PN



QTY 5000_{ea}





Date Code 2132



Lot Code 2065112

32nd week of 2021



- Reel Specification & Packaging Quantity

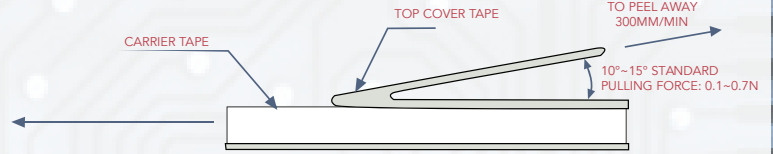
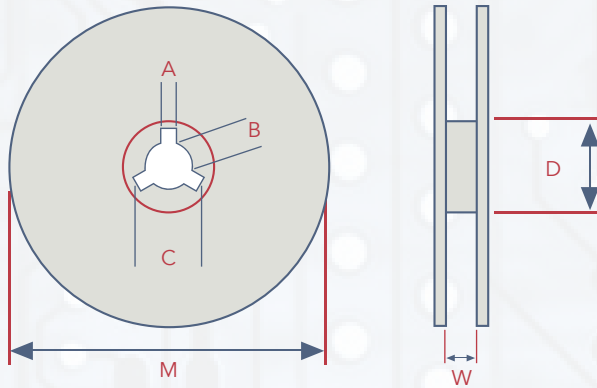

TYPE	QUANTITY / REEL	A ± 0.5	B ± 0.5	C ± 0.5	D ± 1	M ± 2	W ± 1	
CN22	10,000 pcs	2.0	13.0	21.0	60.0	178.0	10.0	
CN24	10,000 pcs							
CN32	5,000 pcs							
CN34	5,000 pcs							
CN48	4,000 pcs						13.8	
CNK22	10,000 pcs							
CNK24	10,000 pcs							
CNK34	5,000 pcs							
CNF12	15,000 pcs							10.0
CNF14	15,000 pcs							

- Dimension of Paper Taping: (mm)

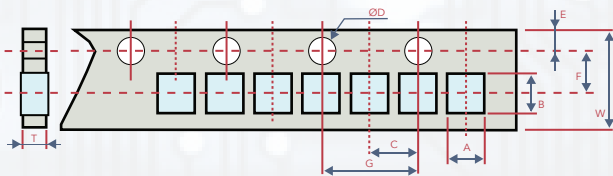

TYPE	A ± 0.02	B ± 0.2	C ± 0.05	ØD+0.1 -0	E ± 0.1	F ± 0.05	G ± 0.1	W ± 0.2	T ± 0.1
CN22 / CNK22	1.20	1.20	2.0	1.5	1.75	3.50	4.00	8.0	0.45
CN24 / CNK 24	1.20	2.20	2.0	1.5	1.75	3.50	4.00	8.0	0.70
CNF12	0.79	1.00	2.0	1.5	1.75	3.50	4.00	8.0	0.50
CNF14	0.90	1.70	2.0	1.5	1.75	3.50	4.00	8.0	0.50

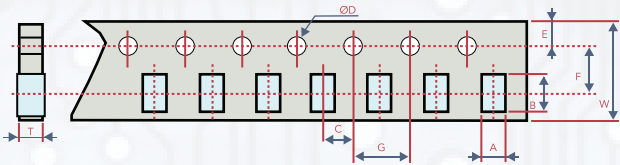

TYPE	A ± 0.02	B ± 0.2	C ± 0.05	ØD+0.1 -0	E ± 0.1	F ± 0.05	G ± 0.1	W ± 0.2	T ± 0.1
CN34 / CNK34	2.00	3.60	2.0	1.5	1.75	3.50	4.00	8.0	0.83
CN32	1.90	1.90	2.0	1.5	1.75	3.50	4.00	8.0	0.83

- Dimension of Embossed taping : (mm)

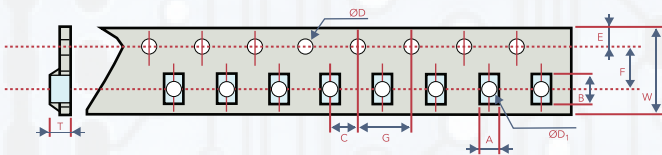

TYPE	A ± 0.02	B ± 0.2	C ± 0.05	ØD+0.1 -0	E ± 0.1	F ± 0.05	G ± 0.1	W ± 0.2	T ± 0.1
CN48	1.80	4.30	2.00	1.50	1.75	5.50	4.00	12.0	0.75