

PRODUCT IDENTIFICATION

- PRODUCT NAME Capacitor (MLCC)
- SERIES CHV
- SIZE 0402
- DIELECTRIC NPO
- WEIGHT 1.32 (max)
- MANUFACTURE NAME Cal-Chip Electronics Inc.
- ADDRESS 59 Steamwhistle Drive, Ivyland, PA 18974

GENERAL COMPOSITION

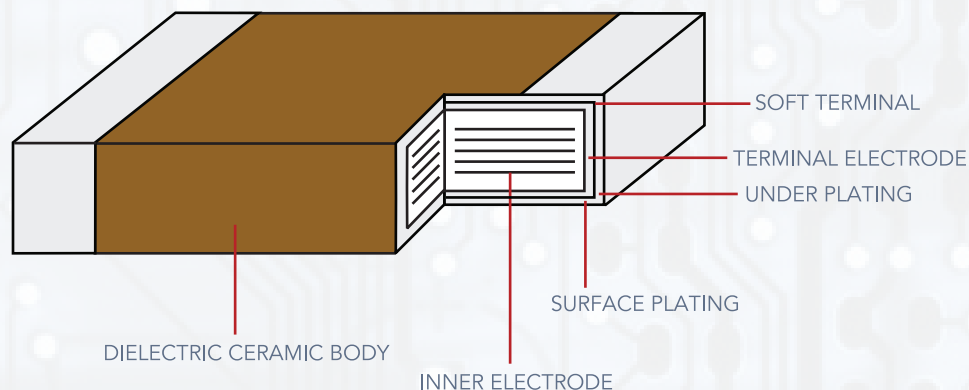

PART	MATERIAL		WEIGHT (mg)	% OF PART	% OF COMPONENT	CAS NO.
Body	Inner Electrode	Ni	0.13	10.09	9.66	7440-02-0
	Dielectric	Calcium Magnesium Titanate	1.14	89.91	86.08	12032-30-3 7439-95-4 12049-50-2
SUBTOTAL			1.27	100.00	95.74	
Termination	Contact with Ceramic	Cu	0.025	44.004	1.875	7440-50-8
	Barrier Layer	Ni	0.013	22.754	0.970	7440-02-0
	Solder Platin	Sn	0.019	33.242	1.417	7440-31-5
SUBTOTAL			0.06	100.00	4.26	
ALL PARTS TOTAL			1.32		100	

MATERIAL DECLARATION

CHV-NPO

PRODUCT IDENTIFICATION

- PRODUCT NAME Capacitor (MLCC)
- SERIES CHV
- SIZE 0603
- DIELECTRIC NPO
- WEIGHT 4.7 (max)
- MANUFACTURE NAME Cal-Chip Electronics Inc.
- ADDRESS 59 Steamwhistle Drive Ivyland, PA 18974

GENERAL COMPOSITION

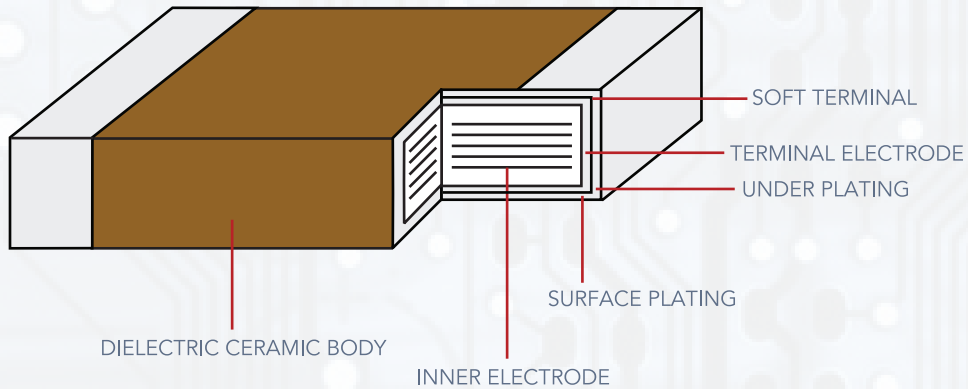

PART	MATERIAL		WEIGHT (mg)	% OF PART	% OF COMPONENT	CAS NO.
Body	Inner Electrode	Ni	0.38	8.44	8.17	7440-02-0
	Dielectric	CaTiO ₃	4.16	91.56	88.61	12047-27-7
SUBTOTAL			4.55	100	96.78	
Termination	Contact with Ceramic	Cu	0.109	72.03	2.32	7440-50-8
	Barrier Layer	Ni	0.021	14.21	0.46	7440-02-0
	Solder Plating	Sn	0.021	13.76	0.44	7440-31-5
SUBTOTAL			0.15	100	3.22	
ALL PARTS TOTAL			4.70		100	



PRODUCT IDENTIFICATION

- PRODUCT NAME Capacitor (MLCC)
- SERIES CHV
- SIZE 0603
- DIELECTRIC X7R
- WEIGHT 6.1 (max)
- MANUFACTURE NAME Cal-Chip Electronics Inc.
- ADDRESS 59 Steamwhistle Drive Ivyland, PA 18974

GENERAL COMPOSITION

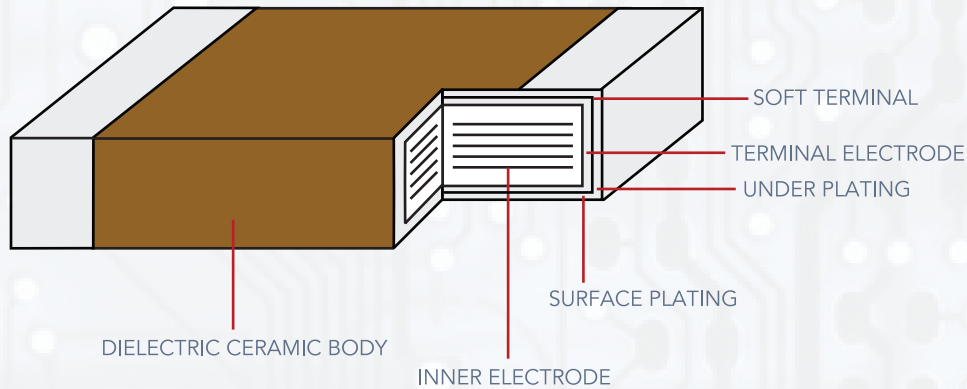

PART	MATERIAL		WEIGHT (mg)	% OF PART	% OF COMPONENT	CAS NO.
Body	Inner Electrode	Ni	1.51	25.34	24.71	7440-02-0
	Dielectric	CaTiO ₃	4.44	74.66	72.81	12047-27-7
SUBTOTAL			5.95	100	97.52	
Termination	Contact with Ceramic	Cu	0.109	72.03	1.78	7440-50-8
	Barrier Layer	Ni	0.021	14.21	0.35	7440-02-0
	Solder Plating	Sn	0.021	13.76	0.34	7440-31-5
SUBTOTAL			0.15	100	2.48	
ALL PARTS TOTAL			6.10		100	

MATERIAL DECLARATION

CHV-NPO

PRODUCT IDENTIFICATION

- PRODUCT NAME Capacitor (MLCC)
- SERIES CHV
- SIZE 0805
- DIELECTRIC NPO
- WEIGHT 7.608 mg
- MANUFACTURE NAME Cal-Chip Electronics Inc.
- ADDRESS 59 Steamwhistle Drive Ivyland, PA 18974

GENERAL COMPOSITION

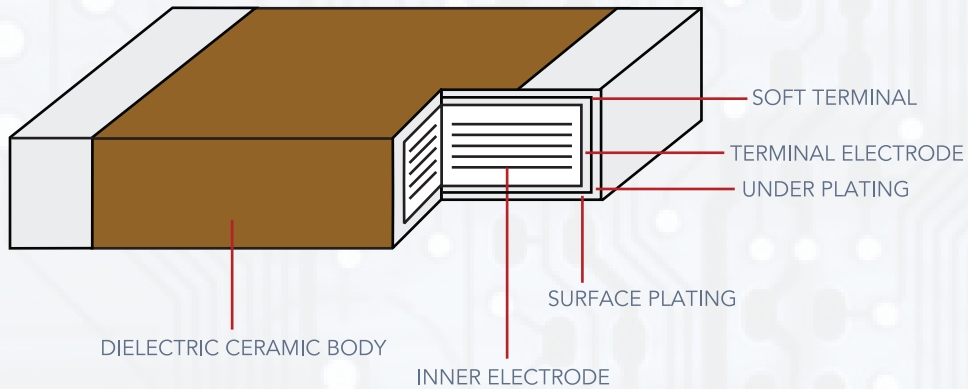

COMPOSITION OF PARTS		MATERIAL				CLASSIFICATION	TYPICAL WEIGHT		
MATERIAL NAME	TYPICAL WT% IN PRODUCT	SUBSTANCE NAME	TYPICAL WT% IN PRODUCT	TYPICAL WT% IN PRODUCT	CAS NO.	USE/PURPOSE OF MATERIAL	SUBSTANCE WEIGHT (mg)	MATERIAL WEIGHT (mg)	PRODUCT WEIGHT (mg)
Dielectric Ceramic Body	90.6	Strontium Oxide	13	11.7780	1314-11-0	Ceramic	0.8961	6.8929	7.608
		Calcium Oxide	15	13.5900	1305-78-8		1.0339		
		Zirconium Dioxide	50	45.3000	1314-23-4		3.4465		
		Titanium Dioxide	2	1.8120	13463-67-7		0.1379		
		Silica	15	13.5900	14808-60-7		1.0339		
		Manganese Tetroxide	5	4.5300	1317-35-7		0.3446		
Inner Electrode	3	Nickel	80	2.4000	7440-02-0	Ni Paste	0.1826	0.2282	7.608
		Barium Titanate	20	0.6000	12047-27-7		0.0456		
Terminal Electrode	6	Copper	88	5.2800	7440-50-8	Cu Paste	0.4017	0.4565	7.608
		Lead Free Glass	12	0.7200	65997-18-4		0.0548		
Under Plating	0.2	Ni	100	0.2000	7440-02-0	Ni Plating	0.0152	0.0152	7.608
Surface Plating	0.2	Matte Sn	100	0.2000	7440-31-5	Sn Plating	0.0152	0.0152	7.608



PRODUCT IDENTIFICATION

- PRODUCT NAME Capacitor (MLCC)
- SERIES X7R
- SIZE 0805
- DIELECTRIC CHV
- WEIGHT 16.8 (max)
- MANUFACTURE NAME Cal-Chip Electronics Inc.
- ADDRESS 59 Steamwhistle Drive Ivyland, PA 18974

GENERAL COMPOSITION

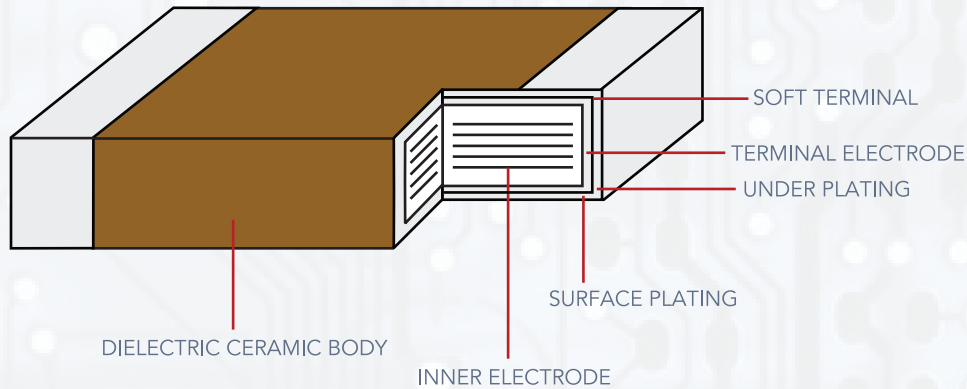

PART	MATERIAL		WEIGHT (mg)	% OF PART	% OF COMPONENT	CAS NO.
Body	Inner Electrode	Ni	0.67	4.06	3.96	7440-02-0
	Dielectric	BaTiO ₃	15.75	95.94	93.78	12047-27-7
SUBTOTAL			16.42	100	97.74	
Termination	Contact with Ceramic	Cu	0.261	68.81	1.55	7440-50-8
	Barrier Layer	Ni	0.017	4.48	0.10	7440-02-0
	Solder Platin	Sn	0.101	26.71	0.60	7440-31-5
SUBTOTAL			0.38	100	2.26	
ALL PARTS TOTAL			16.8		100	

MATERIAL DECLARATION

CHV-NPO

PRODUCT IDENTIFICATION

- PRODUCT NAME Capacitor (MLCC)
- SERIES CHV
- SIZE 1206
- DIELECTRIC NPO
- WEIGHT 19.1 (max)
- MANUFACTURE NAME Cal-Chip Electronics Inc.
- ADDRESS 59 Steamwhistle Drive Ivyland, PA 18974

GENERAL COMPOSITION

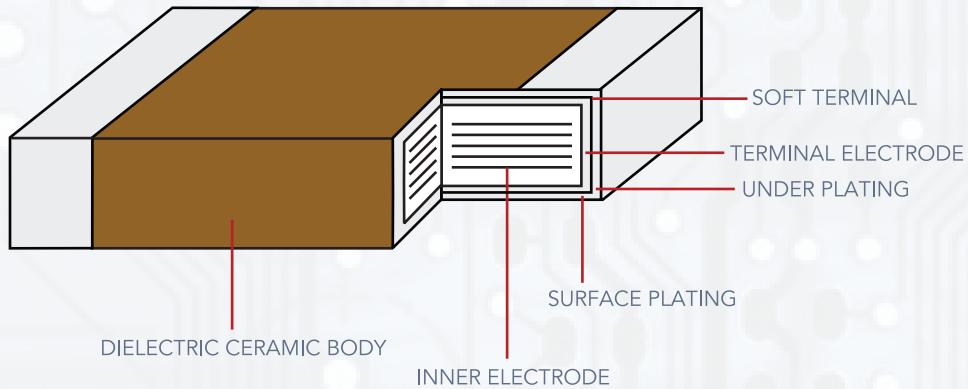

PART	MATERIAL		WEIGHT (mg)	% OF PART	% OF COMPONENT	CAS NO.
Body	Inner Electrode	Ni	0.27	1.45	1.41	7440-02-0
	Dielectric	Calcium Magnesium Titanate	18.32	98.55	95.91	12032-30-3 7439-95-4 12049-50-2
SUBTOTAL			18.59	100	97.31	
Termination	Contact with Ceramic	Cu	0.337	65.70	1.77	7440-50-8
	Barrier Layer	Ni	0.035	6.82	0.18	7440-02-0
	Solder Platin	Sn	0.141	27.48	0.74	7440-31-5
SUBTOTAL			0.51	100	2.69	
ALL PARTS TOTAL			19.1		100	



PRODUCT IDENTIFICATION

- PRODUCT NAME Capacitor (MLCC)
- SERIES CHV
- SIZE 1206
- DIELECTRIC X7R
- WEIGHT 21.5 (max)
- MANUFACTURE NAME Cal-Chip Electronics Inc.
- ADDRESS 59 Steamwhistle Drive Ivyland, PA 18974

GENERAL COMPOSITION

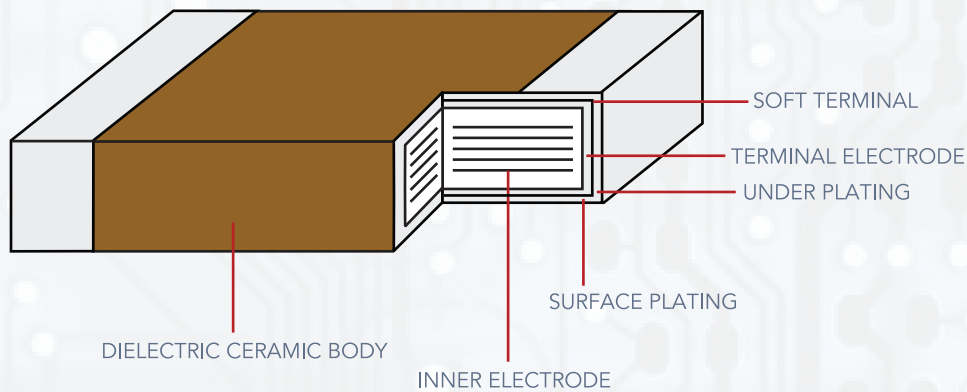

PART	MATERIAL		WEIGHT (mg)	% OF PART	% OF COMPONENT	CAS NO.
Body	Inner Electrode	Ni	0.96	4.57	4.47	7440-02-0
	Dielectric	BaTiO ₃	20.03	95.43	93.14	12047-27-7
SUBTOTAL			20.99	100	97.61	
Termination	Contact with Ceramic	Cu	0.337	65.45	1.57	7440-50-8
	Barrier Layer	Ni	0.037	7.18	0.17	7440-02-0
	Solder Platin	Sn	0.141	27.37	0.66	7440-31-5
SUBTOTAL			0.52	100	2.40	
ALL PARTS TOTAL			21.5		100	

MATERIAL DECLARATION

CHV-NPO

PRODUCT IDENTIFICATION

- PRODUCT NAME Capacitor (MLCC)
- SERIES CHV
- SIZE 1210
- DIELECTRIC NPO
- WEIGHT 43.80 (max)
- MANUFACTURE NAME Cal-Chip Electronics Inc.
- ADDRESS 59 Steamwhistle Drive Ivyland, PA 18974

GENERAL COMPOSITION

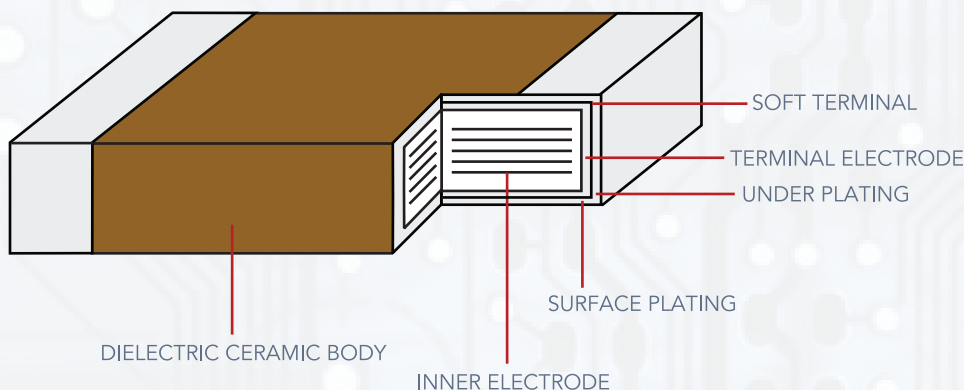

PART	MATERIAL		WEIGHT (mg)	% OF PART	% OF COMPONENT	CAS NO.
Body	Inner Electrode	Ni	3.60	8.41	8.22	7440-02-0
	Dielectric	Calcium Magnesium Titanate	39.19	91.59	89.47	12032-30-3 7439-95-4 12049-50-2
SUBTOTAL			42.79	100	97.69	
Termination	Contact with Ceramic	Cu	0.810	79.897	1.849	7440-50-8
	Barrier Layer	Ni	0.048	4.759	0.110	7440-02-0
	Solder Platin	Sn	0.156	15.344	0.355	7440-31-5
SUBTOTAL			1.01	100	2.31	
ALL PARTS TOTAL			43.8		100.00	



PRODUCT IDENTIFICATION

- PRODUCT NAME Capacitor (MLCC)
- SERIES CHV
- SIZE 1210
- DIELECTRIC X7R
- WEIGHT 118.5 (max)
- MANUFACTURE NAME Cal-Chip Electronics Inc.
- ADDRESS 59 Steamwhistle Drive Ivyland, PA 18974

GENERAL COMPOSITION

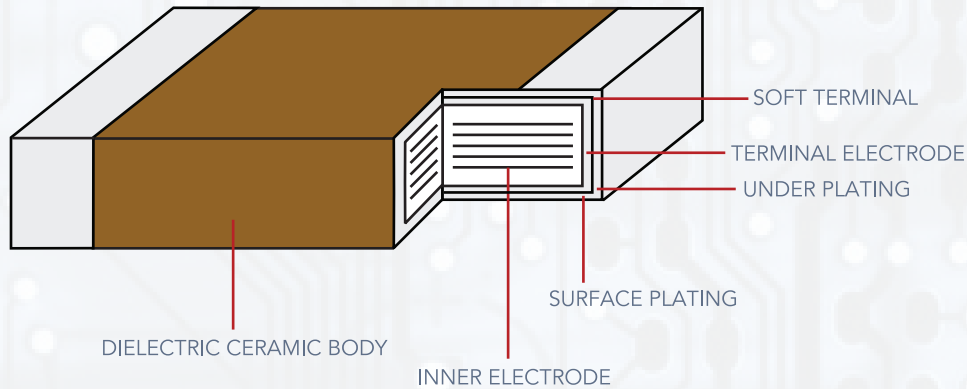

PART	MATERIAL		WEIGHT (mg)	% OF PART	% OF COMPONENT	CAS NO.
Body	Inner Electrode	Ni	5.88	5.00	4.96	7440-02-0
	Dielectric	BaTiO ₃	111.60	95.00	4.18	12047-27-7
SUBTOTAL			117.48	100	99.14	
Termination	Contact with Ceramic	Cu	0.810	79.90	0.68	7440-50-8
	Barrier Layer	Ni	0.048	4.76	0.04	7440-02-0
	Solder Platin	Sn	0.156	15.34	0.13	7440-31-5
SUBTOTAL			1.01	100	0.86	
ALL PARTS TOTAL			118.5		100	

MATERIAL DECLARATION

CHV-NPO

PRODUCT IDENTIFICATION

- PRODUCT NAME	Capacitor (MLCC)
- SERIES	CHV
- SIZE	1808
- DIELECTRIC	NPO
- WEIGHT	120
- MANUFACTURE NAME	Cal-Chip Electronics Inc.
- ADDRESS	59 Steamwhistle Drive Ivyland, PA 18974

GENERAL COMPOSITION

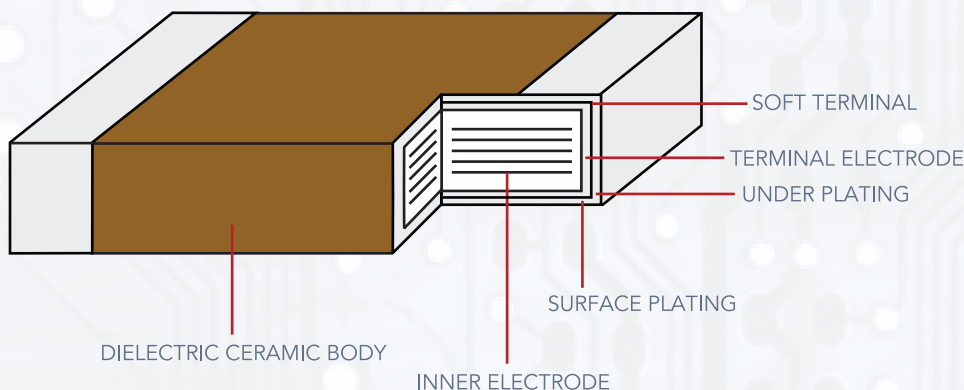

PART	PART WEIGHT (MG)	INNER ELECTRODE	DIELECTRIC	CONTACT WITH CERAMIC	TERMINAL BARRIER LAYER	OUTER SOLDER LAYER
1808	120	10.0%	89.2%	0.5%	0.06%	0.2%

PART	MATERIAL		CAS NO.
Body	Inner Electrode	Ag/Pd	7440-22-4 / 7440-05-3
	Dielectric	Neodium Oxide Titanium Dioxide Barrium Titanate	1313-97-7 13463-67-7 12047-27-7
Termination	Contact with Ceramic	Ag	7440-22-4
	Barrier Layer	Ni	7440-02-0
	Solder Plating	Sn	7440-31-5



PRODUCT IDENTIFICATION

- PRODUCT NAME Capacitor (MLCC)
- SERIES CHV
- SIZE 1808
- DIELECTRIC X7R
- WEIGHT 120
- MANUFACTURE NAME Cal-Chip Electronics Inc.
- ADDRESS 59 Steamwhistle Drive Ivyland, PA 18974

GENERAL COMPOSITION

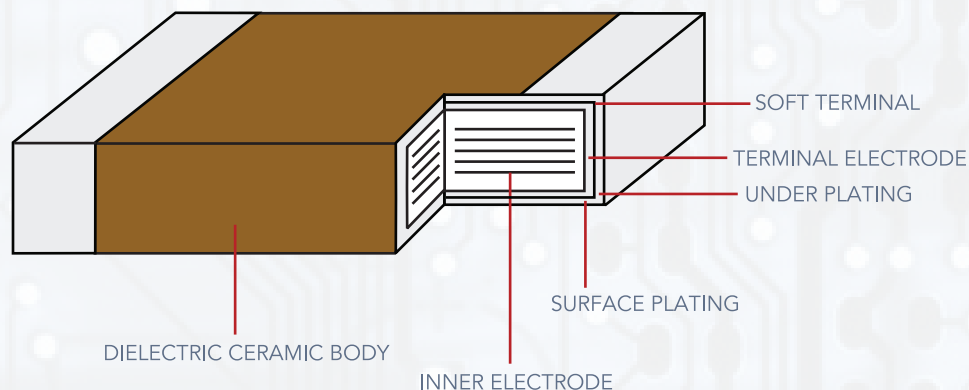

PART	PART WEIGHT (MG)	INNER ELECTRODE	DIELECTRIC	CONTACT WITH CERAMIC	TERMINAL BARRIER LAYER	OUTER SOLDER LAYER
1808	120	10.0%	89.2%	0.5%	0.06%	0.2%

PART	MATERIAL		CAS NO.
Body	Inner Electrode	Ag	7440-22-4
	Dielectric	BaTiO3	12047-27-7
Termination	Contact with Ceramic	Ag	7440-22-4
	Barrier Layer	Ni	7440-02-0
	Solder Plating	Sn	7440-31-5

MATERIAL DECLARATION

CHV-NPO

PRODUCT IDENTIFICATION

- PRODUCT NAME Capacitor (MLCC)
- SERIES CHV
- SIZE 1812
- DIELECTRIC NPO
- WEIGHT 78.7 (max)
- MANUFACTURE NAME Cal-Chip Electronics Inc.
- ADDRESS 59 Steamwhistle Drive Ivyland, PA 18974

GENERAL COMPOSITION

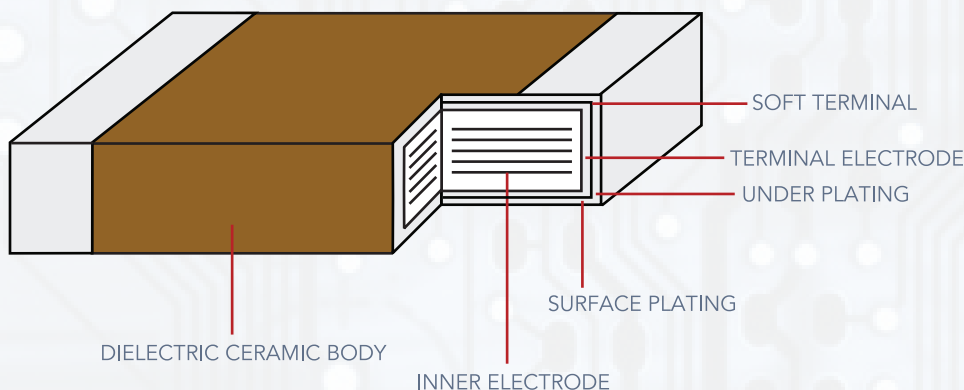

PART	MATERIAL		WEIGHT (mg)	% OF PART	% OF COMPONENT	CAS NO.
Body	Inner Electrode	Ni	4.33	5.56	5.50	7440-02-0
	Dielectric	Calcium Magnesium Titanate	73.44	94.44	93.32	12032-30-3 7439-95-4 12049-50-2
SUBTOTAL			77.77	100.00	98.82	
Termination	Contact with Ceramic	Cu	0.718	77.265	0.912	7440-50-8
	Barrier Layer	Ni	0.069	7.393	0.087	7440-02-0
	Solder Platin	Sn	0.143	15.343	0.181	7440-31-5
SUBTOTAL			0.93	100.00	1.18	
ALL PARTS TOTAL			78.7		100.00	



PRODUCT IDENTIFICATION

- PRODUCT NAME Capacitor (MLCC)
- SERIES CHV
- SIZE 1812
- DIELECTRIC X7R
- WEIGHT 195.2 (max)
- MANUFACTURE NAME Cal-Chip Electronics Inc.
- ADDRESS 59 Steamwhistle Drive Ivyland, PA 18974

GENERAL COMPOSITION

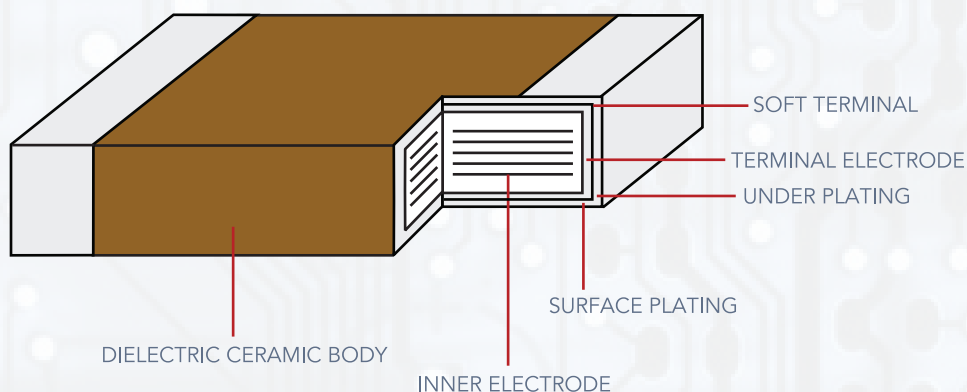

PART	MATERIAL		WEIGHT (mg)	% OF PART	% OF COMPONENT	CAS NO.
Body	Inner Electrode	Ni	68.02	34.97	34.84	7440-02-0
	Dielectric	BaTiO ₃	126.49	65.03	64.80	12047-27-7
SUBTOTAL			194.51	100	99.65	
Termination	Contact with Ceramic	Cu	0.477	69.20	0.24	7440-50-8
	Barrier Layer	Ni	0.070	10.11	0.04	7440-02-0
	Solder Platin	Sn	0.143	20.69	0.07	7440-31-5
SUBTOTAL			0.69	100	0.35	
ALL PARTS TOTAL			195.2		100	

MATERIAL DECLARATION

CHV-NPO

PRODUCT IDENTIFICATION

- PRODUCT NAME	Capacitor (MLCC)
- SERIES	CHV
- SIZE	1825
- DIELECTRIC	NPO
- WEIGHT	650
- MANUFACTURE NAME	Cal-Chip Electronics Inc.
- ADDRESS	59 Steamwhistle Drive Ivyland, PA 18974

GENERAL COMPOSITION

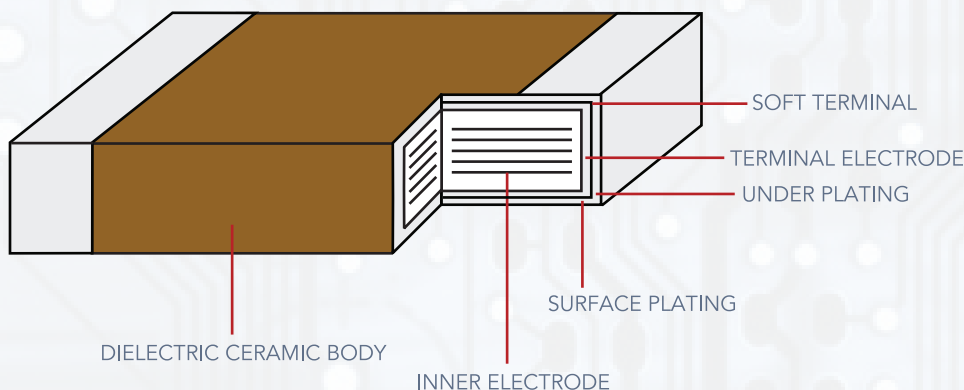

PART	PART WEIGHT (MG)	INNER ELECTRODE	DIELECTRIC	CONTACT WITH CERAMIC	TERMINAL BARRIER LAYER	OUTER SOLDER LAYER
1825	650	11.8%	87.8%	0.2%	0.02%	0.2%

PART	MATERIAL		CAS NO.
Body	Inner Electrode	Ag/Pd	7440-22-4 / 7440-05-3
	Dielectric	Neodium Oxide Titanium Dioxide Barrium Titanate	1313-97-7 13463-67-7 12047-27-7
Termination	Contact with Ceramic	Ag	7440-22-4
	Barrier Layer	Ni	7440-02-0
	Solder Plating	Sn	7440-31-5



PRODUCT IDENTIFICATION

- PRODUCT NAME Capacitor (MLCC)
- SERIES CHV
- SIZE 1825
- DIELECTRIC X7R
- WEIGHT 650 mg
- MANUFACTURE NAME Cal-Chip Electronics Inc.
- ADDRESS 59 Steamwhistle Drive Ivyland, PA 18974

GENERAL COMPOSITION

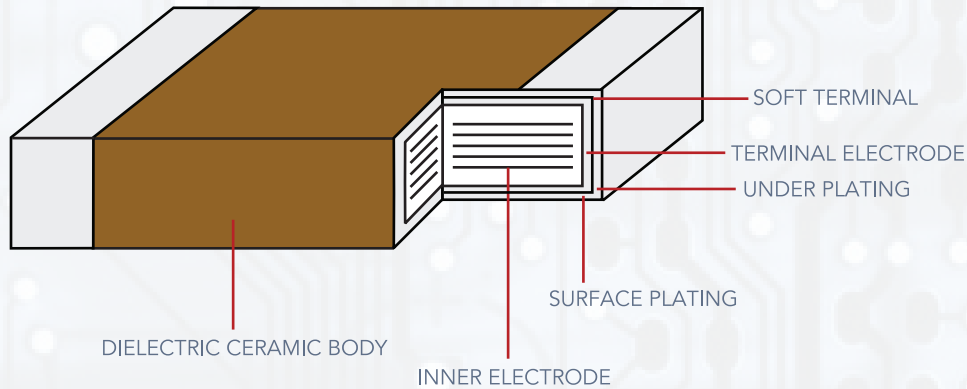

PART	PART WEIGHT (MG)	INNER ELECTRODE	DIELECTRIC	CONTACT WITH CERAMIC	TERMINAL BARRIER LAYER	OUTER SOLDER LAYER
1825	650	11.8%	87.8%	0.2%	0.02%	0.2%

PART	MATERIAL		CAS NO.
Body	Inner Electrode	Ag	7440-22-4
	Dielectric	BaTiO3	12047-27-7
Termination	Contact with Ceramic	Ag	7440-22-4
	Barrier Layer	Ni	7440-02-0
	Solder Plating	Sn	7440-31-5

MATERIAL DECLARATION

CHV-NPO

PRODUCT IDENTIFICATION

- PRODUCT NAME	Capacitor (MLCC)
- SERIES	CHV
- SIZE	2220
- DIELECTRIC	NPO
- WEIGHT	241.8 (max)
- MANUFACTURE NAME	Cal-Chip Electronics Inc.
- ADDRESS	59 Steamwhistle Drive Ivyland, PA 18974

GENERAL COMPOSITION

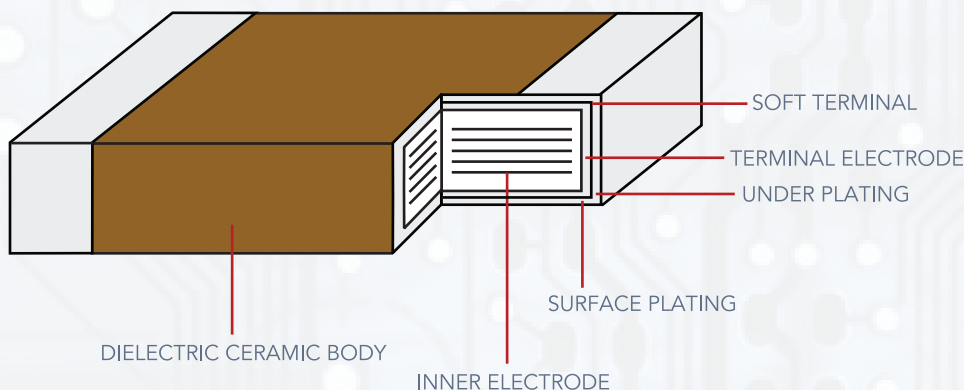

PART	MATERIAL		WEIGHT (mg)	% OF PART	% OF COMPONENT	CAS NO.
Body	Inner Electrode	Ni	10.97	4.56	4.54	7440-02-0
	Dielectric	Calcium Magnesium Titanate	229.60	95.44	94.96	12032-30-3 7439-95-4 12049-50-2
SUBTOTAL			240.58	100.00	99.49	
Termination	Contact with Ceramic	Cu	0.897	73.356	0.371	7440-50-8
	Barrier Layer	Ni	0.059	4.831	0.024	7440-02-0
	Solder Platin	Sn	0.267	21.813	0.110	7440-31-5
SUBTOTAL			1.22	100.00	0.51	
ALL PARTS TOTAL			241.800		100.00	



PRODUCT IDENTIFICATION

- PRODUCT NAME Capacitor (MLCC)
- SERIES CHV
- SIZE 2220
- DIELECTRIC X7R
- WEIGHT 395.8 (max)
- MANUFACTURE NAME Cal-Chip Electronics Inc.
- ADDRESS 59 Steamwhistle Drive Ivyland, PA 18974

GENERAL COMPOSITION

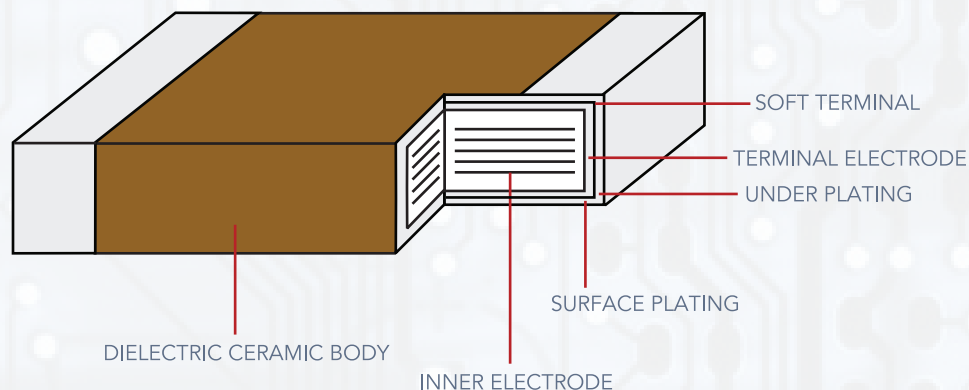

PART	MATERIAL		WEIGHT (mg)	% OF PART	% OF COMPONENT	CAS NO.
Body	Inner Electrode	Ni	130.39	33.06	32.94	7440-02-0
	Dielectric	BaTiO ₃	263.97	66.94	66.69	12047-27-7
SUBTOTAL			394.37	100	99.64	
Termination	Contact with Ceramic	Cu	0.897	62.61	0.23	7440-50-8
	Barrier Layer	Ni	0.069	4.81	0.02	7440-02-0
	Solder Platin	Sn	0.467	32.58	0.12	7440-31-5
SUBTOTAL			1.43	100	0.36	
ALL PARTS TOTAL			395.8		100	

MATERIAL DECLARATION

CHV-NPO

PRODUCT IDENTIFICATION

- PRODUCT NAME Capacitor (MLCC)
- SERIES CHV
- SIZE 2225
- DIELECTRIC NPO
- WEIGHT 760 (max)
- MANUFACTURE NAME Cal-Chip Electronics Inc.
- ADDRESS 59 Steamwhistle Drive Ivyland, PA 18974

GENERAL COMPOSITION

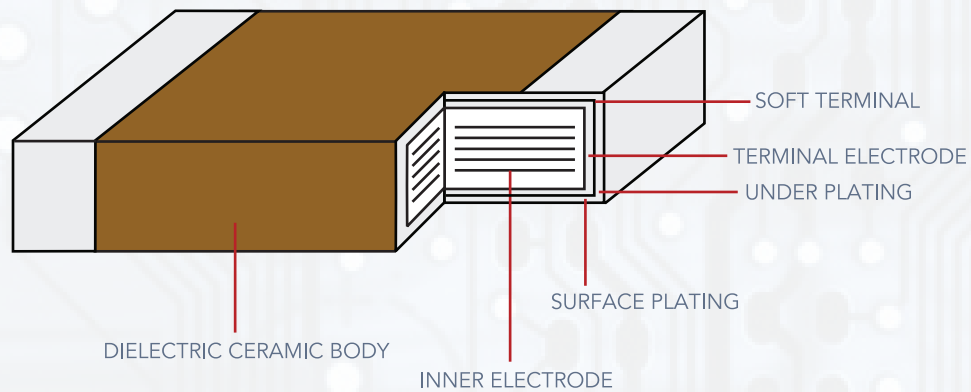

PART	PART WEIGHT (MG)	INNER ELECTRODE	DIELECTRIC	CONTACT WITH CERAMIC	TERMINAL BARRIER LAYER	OUTER SOLDER LAYER
2225	760	12.1%	87.6%	0.1%	0.01%	0.2%

PART	MATERIAL		CAS NO.
Body	Inner Electrode	Ag	7440-22-4
	Dielectric	BaTiO3	12047-27-7
Termination	Contact with Ceramic	Ag	7440-22-4
	Barrier Layer	Ni	7440-02-0
	Solder Plating	Sn	7440-31-5



PRODUCT IDENTIFICATION

- PRODUCT NAME Capacitor (MLCC)
- SERIES CHV
- SIZE 2225
- DIELECTRIC X7R
- WEIGHT 760 (max)
- MANUFACTURE NAME Cal-Chip Electronics Inc.
- ADDRESS 59 Steamwhistle Drive Ivyland, PA 18974

GENERAL COMPOSITION

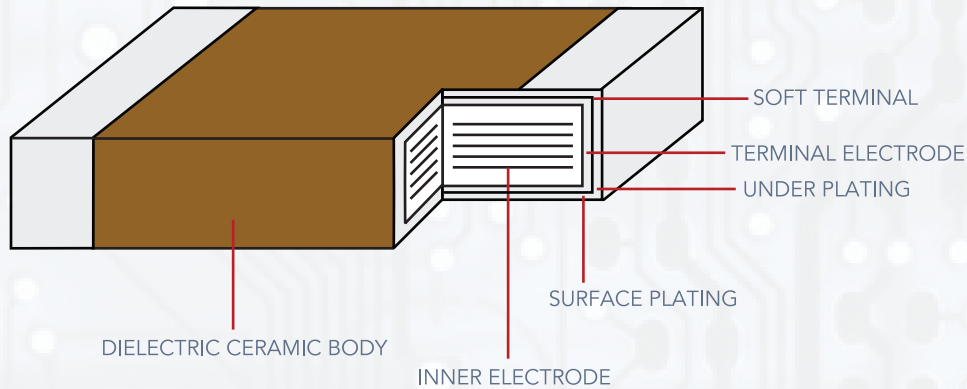

PART	PART WEIGHT (MG)	INNER ELECTRODE	DIELECTRIC	CONTACT WITH CERAMIC	TERMINAL BARRIER LAYER	OUTER SOLDER LAYER
2225	760	12.1%	87.6%	0.1%	0.01%	0.2%

PART	MATERIAL		CAS NO.
Body	Inner Electrode	Ag	7440-22-4
	Dielectric	BaTiO3	12047-27-7
Termination	Contact with Ceramic	Ag	7440-22-4
	Barrier Layer	Ni	7440-02-0
	Solder Plating	Sn	7440-31-5