

RGB LED - 1210

- CC - W2S1210TS - A41 -

FEATURES

- Viewing angle: 140 deg
- The materials of the LED dice is AlGaInP and InGaN
- 3.20mm x 2.70mm x 0.70mm
- RoHS compliant led-free soldering compatible



ATTENTION

OBSERVE PRECAUTIONS
FOR HANDLING
ELECTROSTATIC SENSITIVE DEVICES

PACKAGE OUTLINE

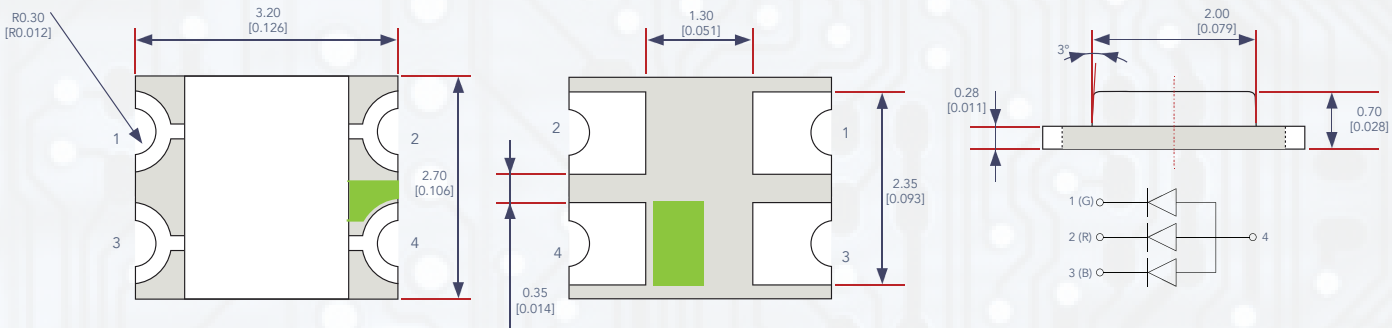

- All dimensions are in millimeters (inches)
- Tolerances are $\pm 0.1\text{mm}$ (0.004 inch) unless otherwise noted

ABSOLUTE MAXIMUM RATINGS AT $T_a - 25^\circ\text{C}$

PARAMETER	SYMBOL	VALUE			UNIT
		R	G	B	
Power Dissipation	Pd	48	68	68	mW
Forward Current	If	20			mA
Reverse Voltage	Vr	5			V
Operating Temperature Range	Top	-40 ~ +100			$^\circ\text{C}$
Storage Temperature Range	Tstg	-40 ~ +100			$^\circ\text{C}$
Peak Pulsing Current	Ifp	100			mA
Electrostatic Discharge	ESD	1000 (HBM)			V

ELECTRO-OPTICAL CHARACTERISTICS AT $T_a - 25^\circ\text{C}$

PARAMETER	TEST CONDITION	SYMBOL	VALUE			UNIT	
			MIN	TYPE	MAX		
Spectral Half Bandwidth	If - 20mA	$\Delta\lambda$	R	-	15	-	nm
			G	-	30	-	
			B	-	30	-	
Forward Voltage	If - 20mA	Vf	R	1.8	-	2.4	V
			G	2.7	-	3.5	
			B	2.7	-	3.5	
Dominant Wavelength	If - 20mA	λ_d	R	630	-	640	nm
			G	515	-	530	
			B	465	-	475	
Luminous Intensity	If - 20mA	Iv	R	35	-	100	mcd
			G	200	-	560	
			B	60	-	200	
Viewing Angle at 50% Iv	If - 20mA	$2\theta_{1/2}$	-	140	-	Deg	
Reverse Current	Vr - 5V	Ir	-	-	10	μA	

NOTE: (Tolerance: Iv $\pm 10\%$, $\lambda_d \pm 2\text{nm}$, Vf $\pm 0.05\text{V}$)
 IFP Conditions: Pulse Width $\leq 10\text{m sec.}$ and Duty $\leq 1/10$.



TYPICAL OPTICAL CHARACTERISTICS CURVES

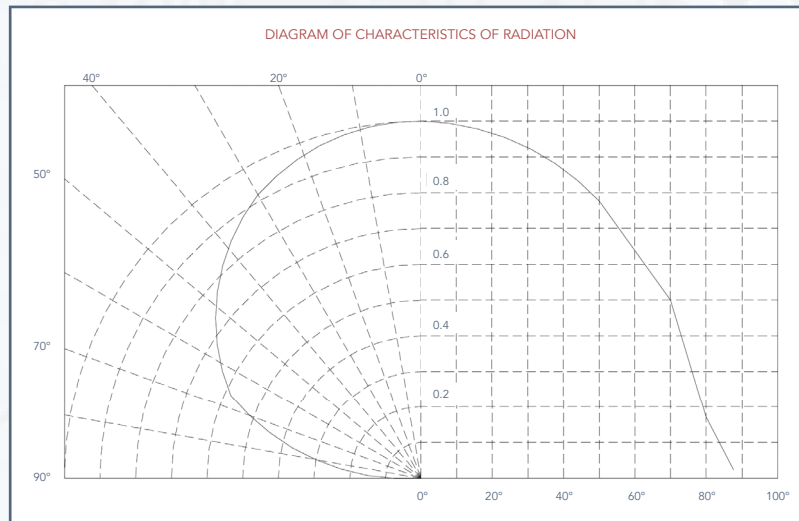
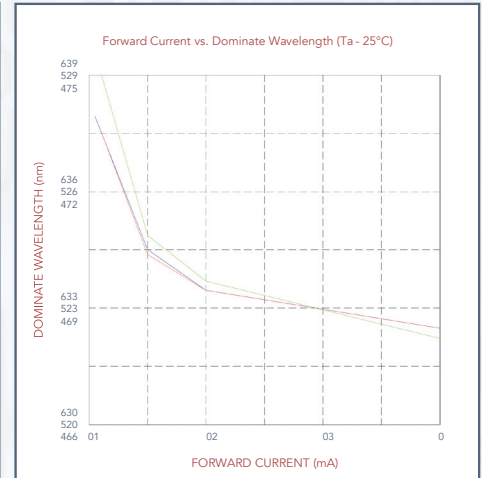
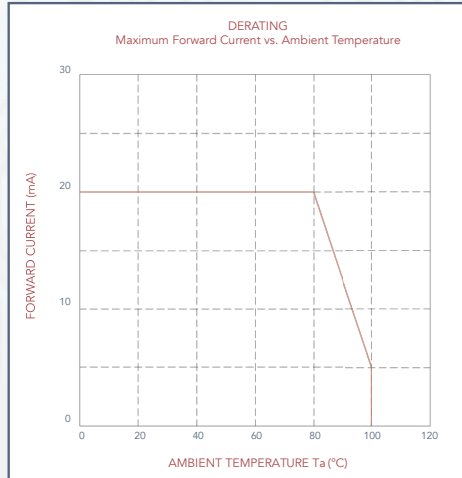
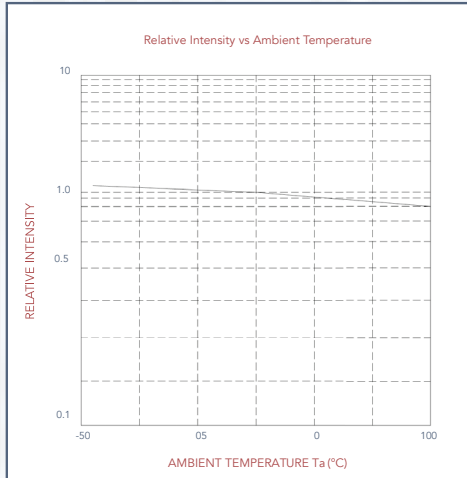
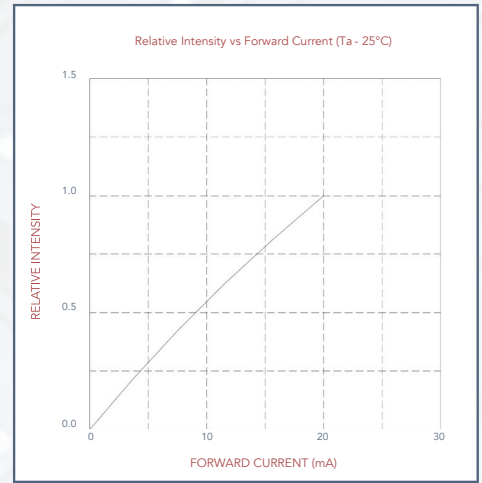
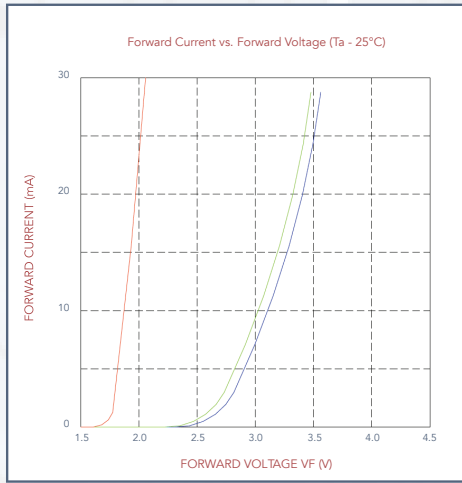
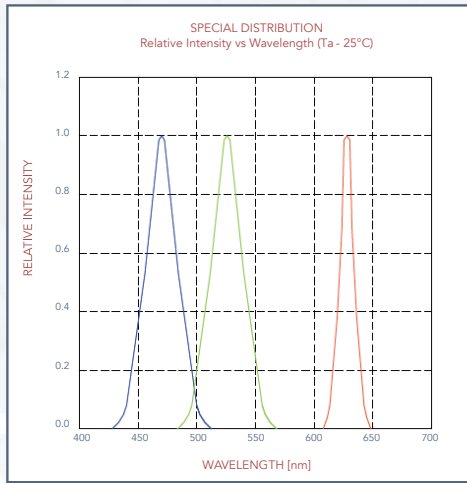

REFLOW PROFILE

- Soldering Condition

Recommended Soldering
After reflow soldering rapid cooling should be avoided

REFLOW SOLDERING		HAND SOLDERING	
Pre-Heat	160°C ~ 180°C	Temperature	300°C
Pre-Heat Time	120 Seconds Max.	Soldering Time	3 Second Max - One Time Only
Peak Temperature	260°C Max		
Soldering Time	10 Seconds Max		
Condition	Refer to Temperature		

- Temperature - profile (surface of circuit board profile)

Use the following Conditions shown in the figure
After reflow soldering, rapid cooling should be avoided

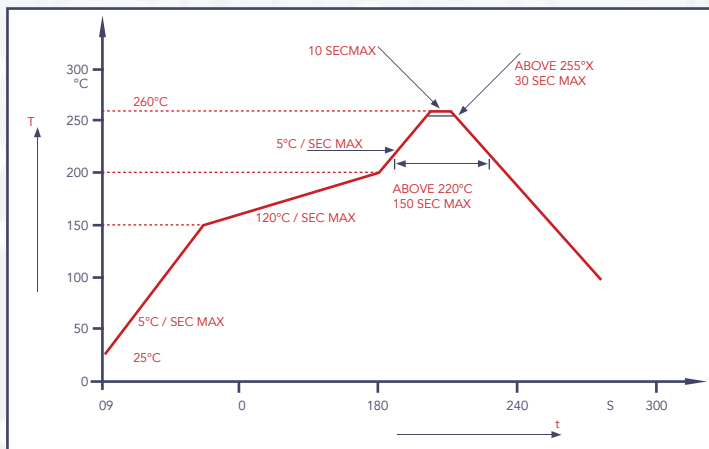

- Recommend Pad Design (Units: mm)

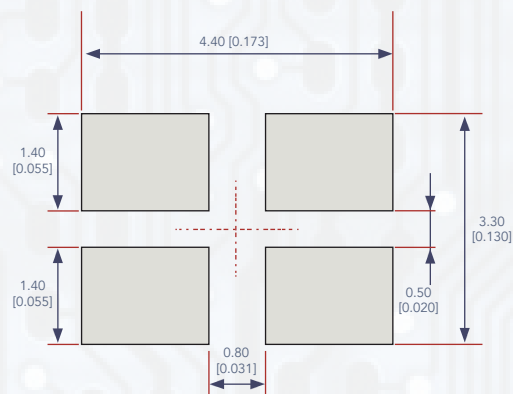

Reflow soldering should not be done more than two times
When soldering, do not put stress on the LEDs during heating

- Soldering Iron

When hand soldering, keep the temperature of the iron under 300°C, and at that temperature keep the time under 3 sec.
The hand soldering should be done only a time
The basic spec is ≤ 5 sec. when the temperature of 260°C, do not contact the resin when hand soldering.

- Rework

Customer must finish rework within 5 sec under 260°C
The head of iron can not touch the resin
Twin-head type is preferred

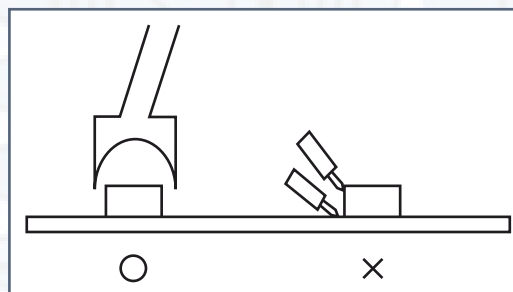

RELIABILITY

- TEST ITEMS AND RESULTS

TYPE	TEST ITEM	REF STANDARD	TEST CONDITIONS	NOTE	NUMBER OF DAMAGED
Environmental Sequence	Resistance to Soldering Heat (Reflow Soldering)	JESD22 - B106	Tsld - 260°C, 10 sec	2 times	0/22
	Temperature Cycle	JESD22 - A104	-40°C 30 min ↓ 5 min 100°C 30 min	300 cycle	0/22
	Thermal Shock	JESD22 - A106	-40°C 15min ↓ 100°C 15 min	300 cycle	0/22
	High Temperature Storage	JESD22 - A103	T _a - 100°C	1000 hrs	0/22
	Low Temperature Storage	JESD22 - A119	T _a - 40°C	1000 hrs	0/22
Operation Sequence	Life Test	JESD22 - A108	T _a - 25°C I _F - 20mA	1000 hrs	0/22
	High Humidity Heat Life Test	JESD22 - A101	60°C RH - 90% I _F - 20mA	1000 hrs	0/22

- CRITERIA FOR JUDGING THE DAMAGE

ITEM	SYMBOL	TEST CONDITIONS	CRITERIA FOR JUDGEMENT	
			MIN.	MAX.
Forward Voltage	VF	IF - 20mA	-	U.S.L *) x 1.1
Reverse Current	IR	VR - 5V	-	U.S.L*) x 2.0
Luminous Intensity	IV	IF - 20mA	L.S.L**) x 0.7	-

- U.S.L.: Upper Standard Level
- L.S.L.: Lower Standard Level

PACKAGING SPECIFICATIONS

- Feeding Direction

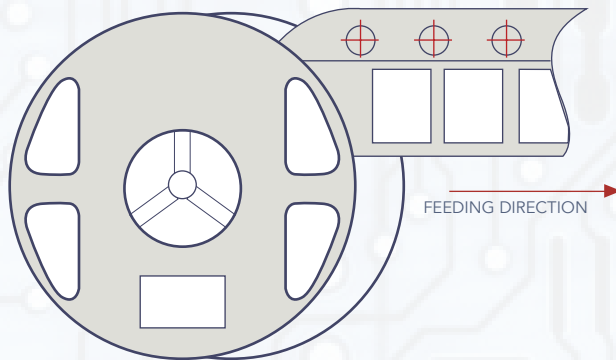

- Dimensions of Reel (Unit: mm)

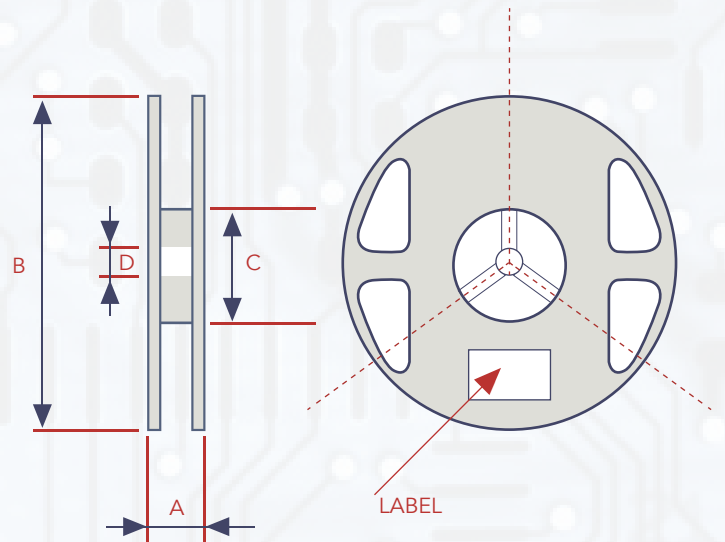

A	8.0 ± 0.1mm
B	178 ± 1mm
C	60 ± 1mm
D	13.0 ± 0.5mm



PACKAGING SPECIFICATIONS

- Dimensions of Tape (Unit: mm)

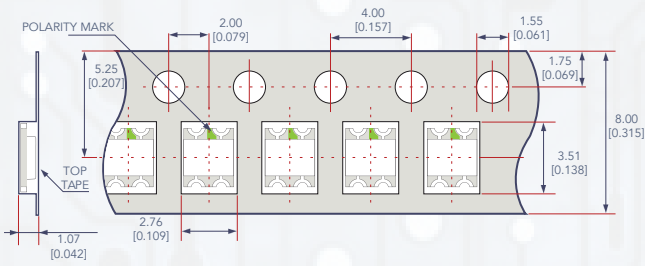

NOTE: Empty component pockets are sealed with top cover tape
The maximum number of missing lamps is two
3,000 pcs / Reel

- Arrangement of Tape

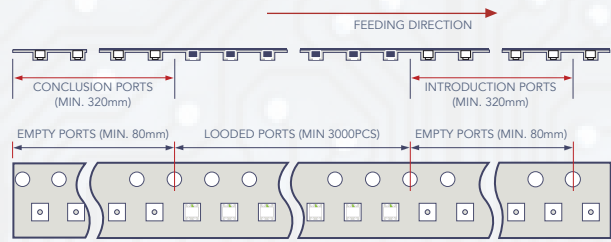

PACKAGING SPECIFICATIONS

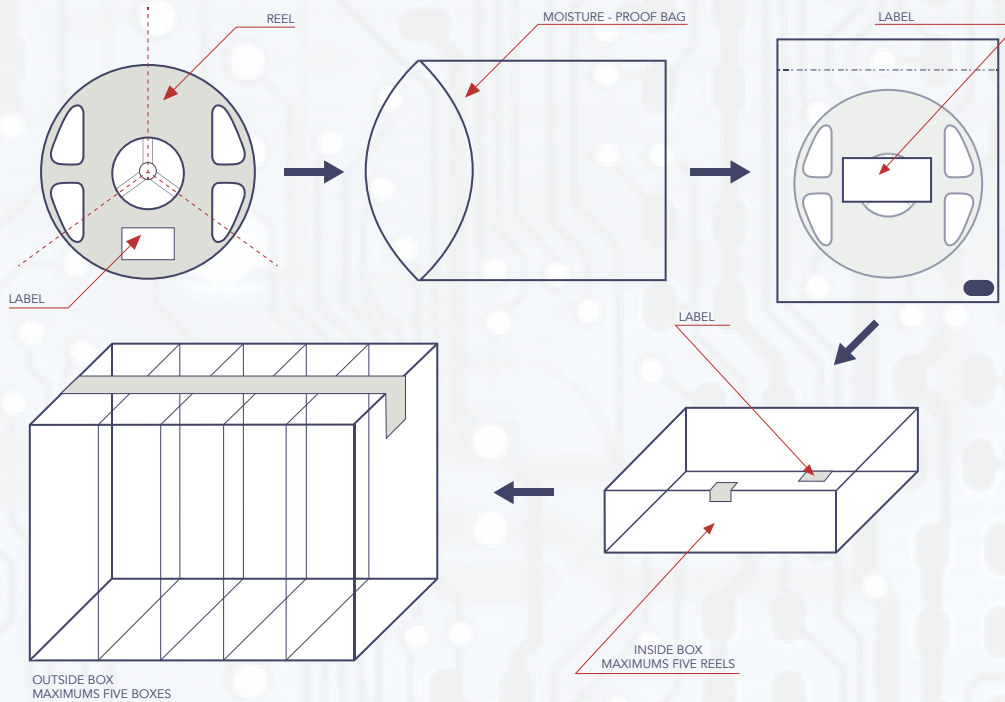

- Label

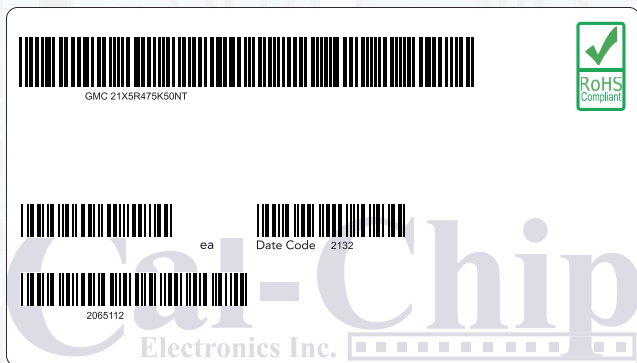

- Cautions

- Packaging Specification

- Reeled products (numbers of products are 3,000pcs) packed in a seal off moisture-proof bag along with a desiccant one by one, Five moisture-proof bag of maximums (total maximum number of products are 15,000pcs) packed in an inside box (size: about 250mm x about 250 x about 68mm) and Five inside boxes of maximums are put the outside box (size: about 360mm x about 265mm x about 255mm) Together with buffer material, and it is packed. (Pare No., Lot No., quantity should appear on the label on the moisture-proof bag, part No. And quantity should appear on the label on the cardboard box.) The number of the loading steps of outside box (cardboard box) has three steps.

- Storage Conditions

- **Before Opening the Packaging** - The LEDs should be kept at 30°C or less and 70%RH or less. The LEDs should be used within a year. When storing the LEDs, moisture proof packaging with absorbent material is recommended.

- **After Opening the Package** - The LEDs should be kept at 30°C or less and 60%RH or less. The LEDs should be soldered within 168 hours (7days) after opening the package. If unused LEDs remain, they should be stored in moisture proof packages, such as sealed containers with packages of moisture absorbent material. It is also recommended to return the LEDs to the original moisture proof bag and to reseal the moisture proof bag again.