

ULTRA LOW OHM (METAL STRIP) CHIP RESISTOR

- RUL SERIES -

FEATURES

- High power rating up to 3 Watts
- Low TCR down to ± 50 PPM/ $^{\circ}$ C
- Resistance values from 0.5m to 15m ohm
- Customized resistance available
- Wide range package sizes 1206 / 2010 / 2512

APPLICATIONS

- NB (for Power Management)
- MB (for Power Management)
- SWPS (DC-DC Converter, Charger, Adaptor)
- Monitor (for Power Management)

CONSTRUCTION

- 1206 & 2010

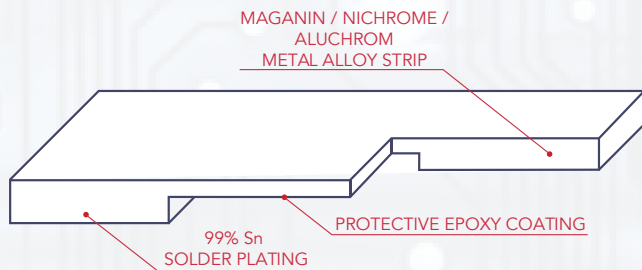

TYPE	MATERIAL
OM50 ~ R003	Manganese, Copper
R004 ~ R010	Aluminum, Iron, Chromium

- IR reflow soldering only

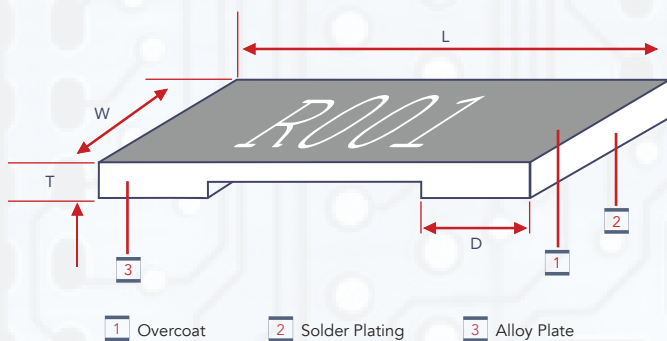

- 2512 Wave or IR reflow soldering

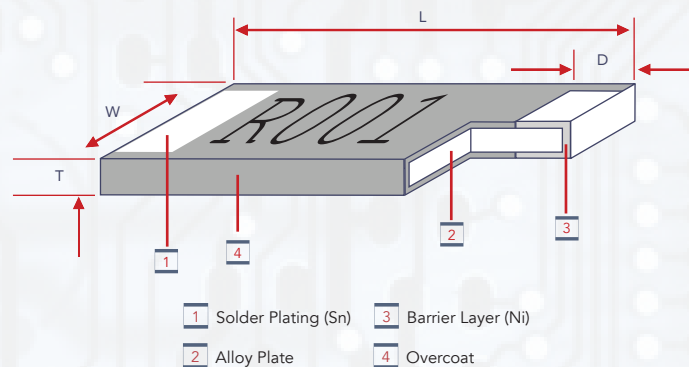

DERATING CURVE

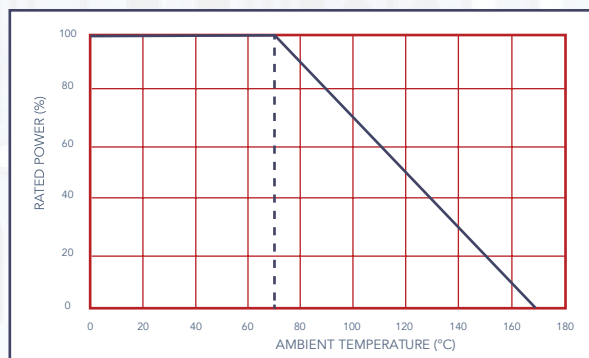

DIMENSIONS

	RESISTANCE (mΩ)	L	W	T	D	WEIGHT (G) (1000PCS)
RUL06_0M50CTF	0.5	3.20 ± 0.25	1.60 ± 0.10	0.60 ± 0.20	1.35 ± 0.25	22.6
RUL06_0M75CTD	0.75				1.23 ± 0.25	
RUL06_____CT_	1.0, 4.0, 5.0, 6.0				1.10 ± 0.25	
RUL06_____CT_	2.0, 3.0, 10				0.60 ± 0.25	
RUL06_____CT_	7.0, 8.0, 9.0				0.90 ± 0.25	
RUL20_0M50CTEA	0.5	5.08 ± 0.25	2.54 ± 0.15	0.60 ± 0.20	2.17 ± 0.25	42.3
RUL20_0M75CTDA	0.75				2.04 ± 0.25	
RUL20_R001CTDA	1.0				1.84 ± 0.25	
RUL20_____CTDA	2.0, 6.0, 7.0, 8.0				1.54 ± 0.25	
RUL20_R003CTDA	3.0				1.04 ± 0.25	
RUL20_____CTDA	4.0, 5.0	1.84 ± 0.25				
RUL20_____CTDA	9.0, 10	1.39 ± 0.25				
RUL25_0M50CT_G	0.50	6.35 ± 0.25	3.00 ± 0.20	0.60 ± 0.20	2.68 ± 0.25	59.13
RUL25_0M75CT_G	0.75				2.48 ± 0.25	
RUL25_____CT_G	1.0, 0.6				1.93 ± 0.25	
RUL25_____CT_G	1.5, 6.5, 7.0				1.43 ± 0.25	
RUL25_____CT_G	2.0, 3.0				1.18 ± 0.25	
RUL25_____CT_G	4.0, 4.5	2.18 ± 0.25				
RUL25_____CT_G	5.0, 6.0	1.93 ± 0.25				
RUL25_____CT_G	8.0 - 15	1.18 ± 0.25				
RUL25_0M50CT_	0.50	6.35 ± 0.254	3.18 ± 0.254	1.25 ± 0.20	1.30 ± 0.38	181.10
RUL25_0M75CT_	0.75			0.75 ± 0.20		127.06
RUL25_R001CT_	1.00			0.65 ± 0.20		108.10
RUL25_1M50CT_	1.50			0.45 ± 0.20		63.92
RUL25_R002CT_	2.00			0.35 ± 0.20		46.92
RUL25_2M50CT_	2.50			0.65 ± 0.20		97.95
RUL25_R003CT_	3.00			0.55 ± 0.20		83.49
RUL25_R004CT_	4.00			0.45 ± 0.20		62.59
RUL25_R005CT_	5.00			0.35 ± 0.20		49.84
RUL25_R006CT_	6.00			0.32 ± 0.20		41.76
RUL25_6M50CT_	6.50			0.30 ± 0.20		35.85
RUL25_R007CT_	7.00			0.27 ± 0.20		34.01
RUL25_R010CT_	10.00			0.25 ± 0.20		25.97

PART NUMBERING

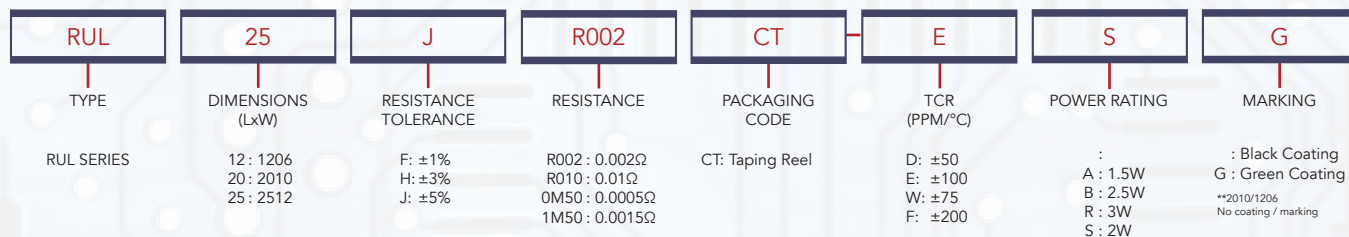

STANDARD ELECTRICAL SPECIFICATIONS

TYPE	POWER RATING AT 70°C	OPERATING TEMP RANGE	RESISTANCE RANGE (mΩ)			T.C.R. (PPM / °C)
			±1%	±3%	±5%	
RUL12_0M50CTF	1W	-55~+170°C	0.5			±200
RUL12_____CTD			0.75 - 10			±50
RUL25_____CTD			0.5, 0.75, 1, 1.5, 2			±50
RUL25_____CTW			6, 6.5, 7			±75
RUL25_____CTE			4, 5, 10			±100
RUL25_____CTK			2.5, 3			±150
RUL25_____CTDG			11, 12, 13, 14, 15			±50

HIGH POWER RATING ELECTRICAL SPECIFICATIONS

TYPE ITEM	POWER RATING AT 70°C	OPERATING TEMP RANGE	RESISTANCE RANGE (mΩ)			T.C.R. (PPM / °C)
			±1%	±3%	±5%	
RUL20_0M50CTEA	1.5W	-55~+170°C	0.5			±100
RUL20_____CTDA			0.75 - 10			±50
RUL25_____CTDS			0.5, 0.75, 1, 1.5, 2			±75
RUL25_____CTWS	2W		6, 6.5, 7			±100
RUL25_____CTES			4, 5, 10			±150
RUL25_____CTKS			2.5, 3			±50
RUL25_____CTDSG			6.5, 7, 8, 9, 10			±100
RUL25_____CTDBG	2.5W		4, 4.5, 5, 6			±50
RUL25_____CTDRG	3W		1, 1.5, 2, 3			±100
RUL25_____CTERG		0.5, 0.75			±100	

Operating Voltage $\sqrt{(P \cdot R)}$;

Overload Voltage $\sqrt{(P \cdot R)}$;

- Cal-Chip has the ability to manufacture the following options based on customer requirements

RESISTANCE CODES EXAMPLE

- Resistance (3 Marking)

RESISTANCE	0.5mΩ	0.75mΩ
MARKING	M50	M75

- Resistance (4 Marking)

RESISTANCE	1mΩ	1.5mΩ	2mΩ	7mΩ	10mΩ
MARKING	R001	1M50	R002	R007	R010

REFLOW

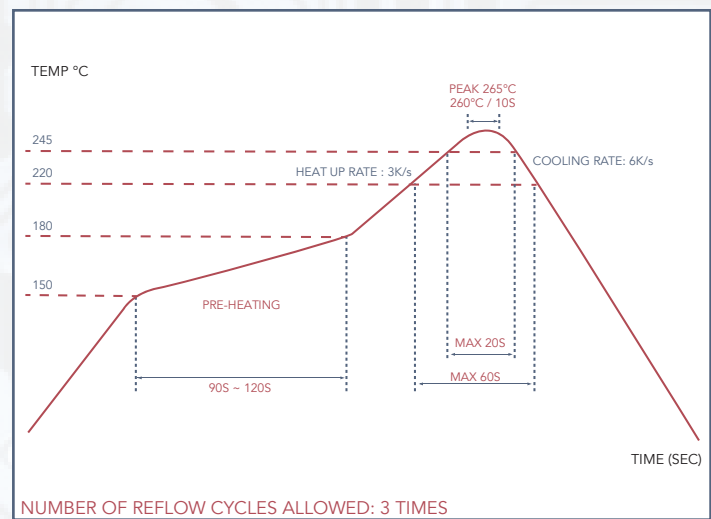

- Green coating "Reflow Air Convection" is available
 - Green coating can't be working with wave soldering path

ENVIRONMENTAL CHARACTERISTICS

ITEMS	REQUIREMENT		TEST METHOD
	BLACK COATING	GREEN COATING	
Temperature Coefficient of Resistance (T.C.R.)	As Spec.		MIL-STD-202 METHOD 304 +25/-55/+25/+125/+25°C
Short Time Overload	±0.5%	±1%	JIS-C-5201-1 5.5 5* rated power for 5 seconds
Endurance	±1%	±1%	MIL-STD-202 METHOD 108A 70 ± 2°C, RCWW for 1000 hrs with 1.5 hrs "ON" and 0.5 hrs "OFF"
Dry Heat	±1%	±1%	JIS-C-5201-1 7.2 at +170°C for 1000 hrs
Solderability	95% min. coverage		MIL-STD-202 METHOD 208H 245±5°C for 3 seconds
Resistance to Soldering Heat	±0.5%	±1%	MIL-STD-202 METHOD 210E 260±5°C for 10 seconds
Thermal Shock	±0.5%	±1%	MIL-STD-202 MEHTOD 107G -55°C ~ 150°C, 100 Cycles

**Green coating can't be work with wave soldering bath.
RCWW (Rated continuous working voltage) - $\sqrt{P \cdot R}$ or Max. Operating voltage whichever is lower

- Storage Temperature: 25 ± 3°C; Humidity <80% RH

MEASUREMENTS

- RUL25 4-wire precision measurement (Black Coating)
Equipment: ADEX AX-1152D DC Low Ohm Meter
Excitation Current: 3A (0.5mΩ ~ 1.5mΩ)
1A (2mΩ ~ 10mΩ)

- RUL25 4-wire pad layout (recommended for precision current sensing)
Note: No circuits between pads to avoid short circuit

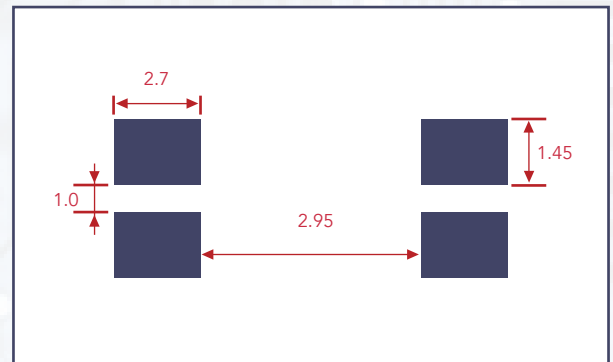
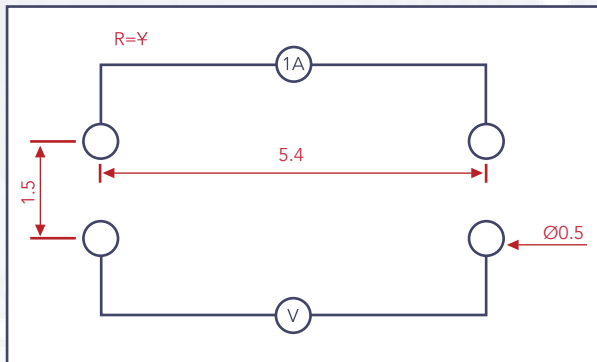

- RUL25 2-wire pad layout
Note: No circuits between pads to avoid short circuit

- RUL25 4-wire precision measurement (Green Coating)
Equipment: ADEX AX-1152D DC Low Ohm Meter
Excitation Current: 3A (0.5mΩ ~ 1.5mΩ)
1A (2mΩ ~ 15mΩ)

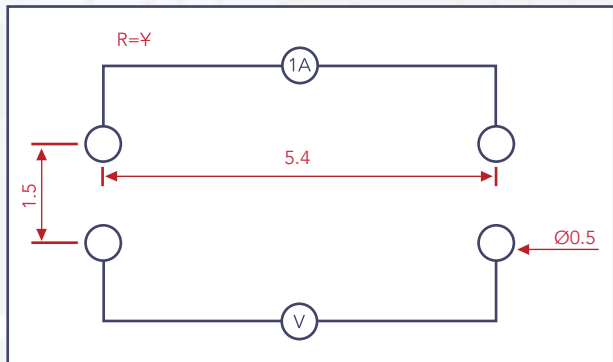
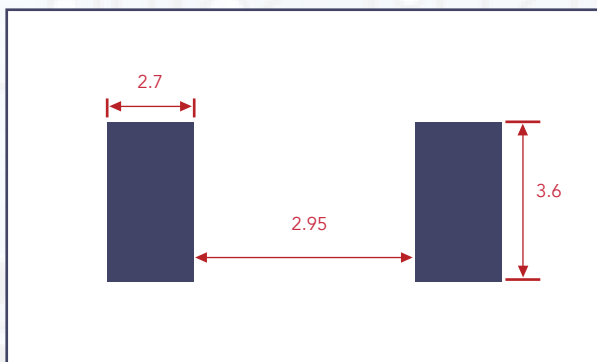

MEASUREMENTS

- RUL25 4-wire pad layout (recommended for precision current sensing)

Note: No circuits between pads to avoid short circuit

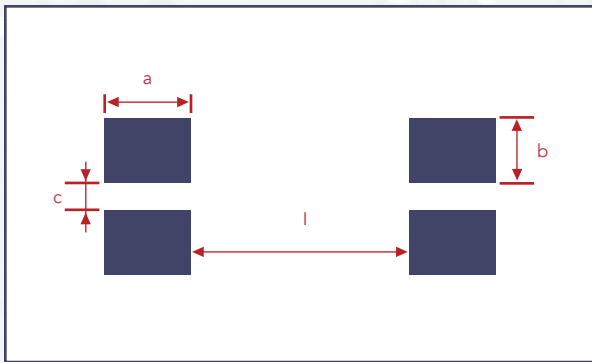

TYPE ITEM	a M/M	b M/M	C M/M	l M/M
OM50	3.13	1.2	1.0	0.52
OM75	2.93			0.94
R001	2.38			2.04
1M5	1.88			3.04
R002-R003	1.63			3.54
R004 - 4M5	2.63			1.54
R005 - R006	2.38			2.04
6M5 - R007	1.88			3.04
R008 - R015	1.63			3.54

- RUL12 2-wire pad layout

Note: No circuits between pads to avoid short circuit

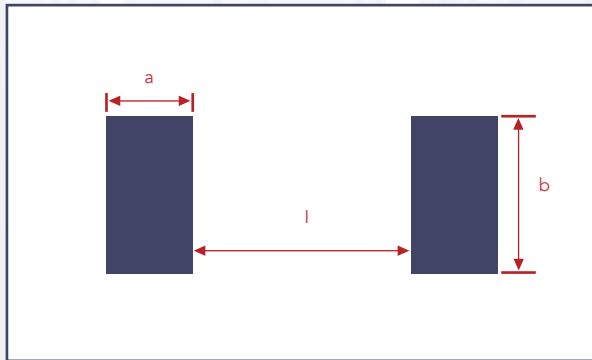

TYPE ITEM	a M/M	b M/M	l M/M	
OM50	1.80	1.90	0.55	
OM75	1.68			
R001	1.55	1.89	1.55	
R002-R003	1.05			
R004 - R006	1.55			
R007 - R009	1.35			
R010	1.05			0.95
				1.55

- RUL20 4-wire precision measurement

Equipment: ADEX AX-1152D DC Low Ohm Meter

Excitation Current: 3A (0.5mΩ ~ 1.5mΩ)

1A (2mΩ ~ 10mΩ)

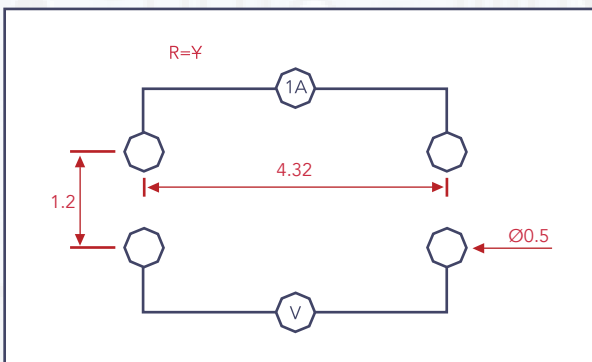

MEASUREMENTS

- RUL20 4-wire pad layout (recommended for precision current sensing)

Note: No circuits between pads to avoid short circuit

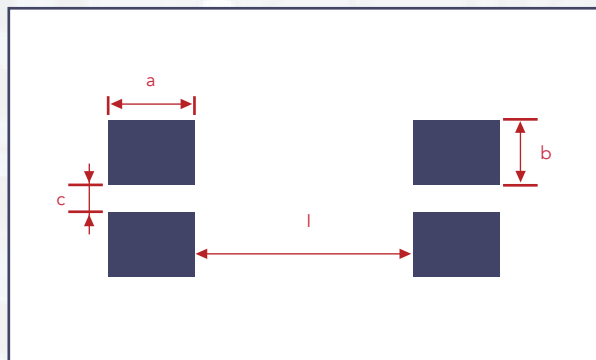

TYPE ITEM	a M/M	b M/M	C M/M	l M/M
OM50	2.61	1.045	0.8	0.60
OM75	2.49			0.80
R001	2.29			0.95
R002	1.99			1.55
R003	1.49			2.55
R004 - R005	2.29			0.95
R006 - R008	1.99			1.55
R009 - R010	1.74			2.05

- RUL20 2-wire pad layout

Note: No circuits between pads to avoid short circuit

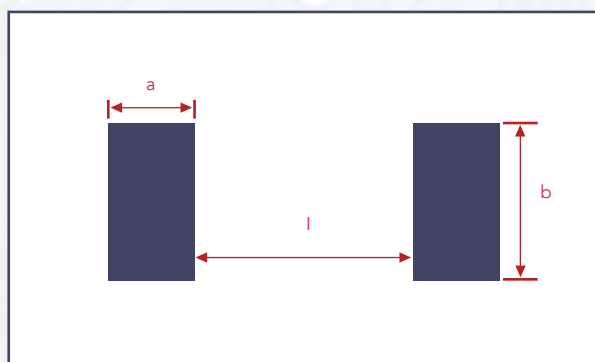

TYPE ITEM	a M/M	b M/M	l M/M
OM50	2.61	2.89	0.60
OM75	2.49		0.80
R001	2.29		0.95
R002	1.99		1.55
R003	1.49		2.55
R004 - R005	2.29		0.95
R006 - R008	1.99		1.55
R009 - R010	1.74		2.05

PACKAGING

- Embossed Plastic Tape Specification

1. The cumulative tolerance of 10 sprockets hole pitch is $\pm 0.2\text{mm}$
2. Carrier camber shall be not more than 1mm per 100mm through a length of 250 mm
3. A&B measured 0.3mm on the bottom of the packet
4. T measured at a point on the inside bottom of the packet to the top surface of the carrier
5. Pocket position relative to sprocket hole is measured as the true position of the pocket and not the pocket hole

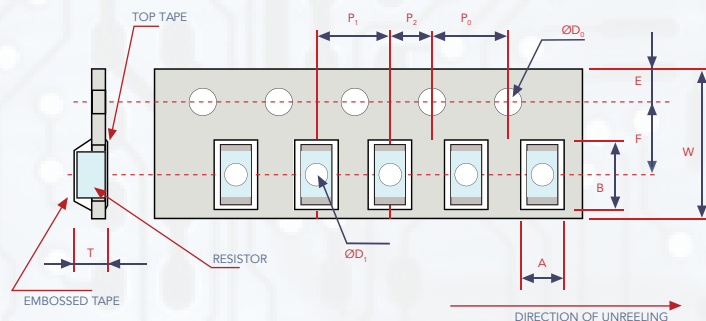

TYPE	RESISTANCE (mΩ)	A	B	W	E	F	P ₀	P ₁	P ₂	ØD ₀	ØD ₁	T	QUANTITY (EA)
RUL12	0.5 - 10	1.90 ± 0.1	3.60 ± 0.1	8.0 ± 0.2		3.5 ± 0.5						1.0 min.	0.87 ± 0.1
RUL20		2.85 ± 0.1	5.55 ± 0.1	12.0 ± 0.2								0.85 ± 0.1	
RUL25	0.50 - 0.75	3.40 ± 0.1	6.75 ± 0.1	12.0 ± 0.1	1.75 ± 0.1	5.5 ± 0.5	4.0 ± 0.1	4.0 ± 0.1	2.0 ± 0.05	1.55 ± 0.05		1.4 min.	1.45 ± 0.2
	1 - 10												0.81 ± 0.1
RUL25 (G)	0.50 - 15												2,000

