

PULSE WITHSTANDING CHIP RESISTOR

- PWR SERIES -

FEATURES

- Tolerance from $\pm 0.5\%$ ~ 5%
- High power rating
- Excellent pulse withstanding performance
- Improved working voltage ratings
- Standard package sizes of 0603 - 2512
- AEC-Q200 Compliance

APPLICATIONS

- Metering (Testing / Measurement)
- Diagnostic Equipment
- Medical Devices
- Industrial Controls
- Plasma
- LCD Video Monitors

DERATING CURVE

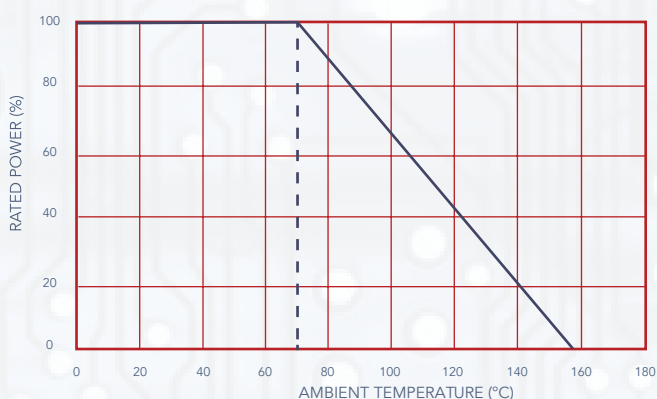

CONSTRUCTION & DIMENSIONS

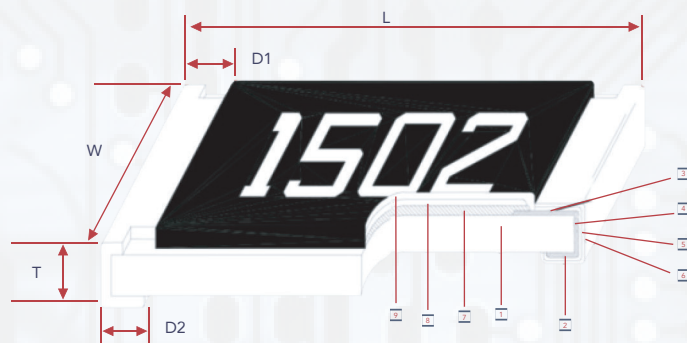

- 1 Alumina Substrate
- 2 Bottom Electrode (Ag)
- 3 Top Electrode (Ag-pd)
- 4 Edge Electrode (NiCr)
- 5 Barrier Layer (Ni)
- 6 External Electrode (Sn)
- 7 Resistor Layer (Ag/Pd)
- 8 Primary Overcoat (Glass)
- 9 Secondary Overcoat (Epoxy)

TYPE	SIZE (INCH)	L (MM)	W (MM)	T (MM)	D ₁ (MM)	D ₂ (MM)	WEIGHT (G) (1000PCS)
PWR06	0603	1.6±0.10	0.80±0.10	0.45±0.10	0.30±0.20	0.30±0.20	2.042
PWR10	0805	2.00±0.10	1.25±0.10	0.50±0.10	0.35±0.20	0.40±0.20	4.368
PWR12	1206	3.10±0.10	1.55±0.10	0.55±0.10	0.50±0.25	0.50±0.20	8.947
PWR14	1210	2.60±0.15	2.60±0.15		15.959		
PWR20	2010	5.00±0.10	2.50±0.15	0.60±0.25	0.60±0.25	0.60±0.25	24.241
PWR25	2512	6.35±0.10	3.10±0.15				39.448

PART NUMBERING

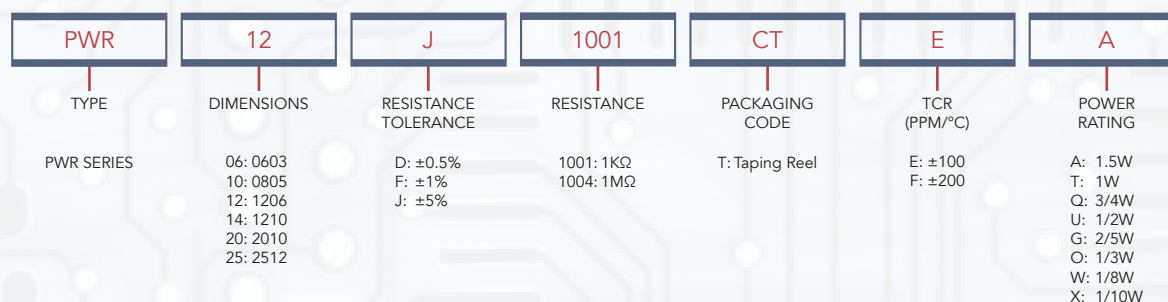

STANDARD ELECTRICAL SPECIFICATIONS

TYPE	SIZE (INCH)	POWER RATING AT 70°C	OPERATING TEMPERATURE RANGE	MAX OPERATING VOLTAGE	MAX OVERLOAD VOLTAGE	RESISTANCE RANGE			TCR (PPM/°C)
						±1% (E24, E96)	±1% (E24, E96)	±5% (E24)	
PWR06	0603	1/10W	-55~+155°C	50V	100V	10Ω - 294Ω	1Ω - 294Ω		±200
						300Ω - 1MΩ			±100
PWR10	0805	1/8W		150V	300V	10Ω - 294Ω	1Ω - 294Ω		±200
						300Ω - 20MΩ			±100
PWR12	1206	1/3W		200V	400V	10Ω - 20Ω	1Ω - 20Ω		±200
						20.5Ω - 20MΩ			±100
PWR14	1210	1/2W		200V		10Ω - 20Ω	1Ω - 20Ω		±200
			20.5Ω - 20MΩ			±100			
PWR20	2010	3/4W	400V	800V	10Ω - 20Ω	1Ω - 20Ω		±200	
					20.5Ω - 20MΩ			±100	
PWR25	2512	1.5W	500V	1000V	10Ω - 20Ω	1Ω - 20Ω		±200	
					20.5Ω - 20MΩ			±100	

HIGH POWER RATING ELECTRICAL SPECIFICATIONS

TYPE	SIZE (INCH)	POWER RATING AT 70°C	OPERATING TEMPERATURE RANGE	MAX OPERATING VOLTAGE	MAX OVERLOAD VOLTAGE	RESISTANCE RANGE			TCR (PPM/°C)
						±1% (E24, E96)	±1% (E24, E96)	±5% (E24)	
PWR06	0603	1/4W	-55~+155°C	75V	150V	10Ω - 294Ω	1Ω - 294Ω		±200
						300Ω - 1MΩ			±100
PWR10	0805	2/5W		150V	300V	10Ω - 294Ω	1Ω - 294Ω		±200
						300Ω - 1MΩ			±100
PWR12	1206	1/2W		200V	400V	10Ω - 20Ω	1Ω - 20Ω		±200
						20.5Ω - 1MΩ			±100
PWR14	1210	3/4W		200V		10Ω - 20Ω	1Ω - 20Ω		±200
			20.5Ω - 1MΩ			±100			
PWR20	2010	1W	400V	800V	10Ω - 20Ω	1Ω - 20Ω		±200	
					20.5Ω - 1MΩ			±100	

Operating Voltage - $\sqrt{P \cdot R}$; or Max. Operating Voltage listed above, whichever is lower.
 Operating Current - $2.5 \cdot \sqrt{P \cdot R}$ or Max. Operating Voltage listed above, whichever is lower.
 Cal-Chip is capable of manufacturing the optional spec based on customer's requirement.

SOLDERING CONDITION

- Pulse Withstanding Chip Resistor
- (1) Time of IR reflow soldering at maximum temperature point 260°C : 10s

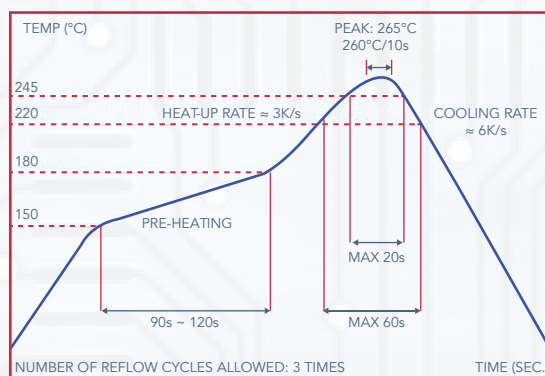

IR REFLOW SOLDERING



ENVIRONMENTAL CHARACTERISTICS

ITEM	REQUIREMENT	TEST METHOD
Temperature Coefficient of Resistance (T.C.R.)	As Spec.	JIS-C-5201-1 4.8 IEC-60115-1 4.8 -55°C ~ +125°C, 25°C is the reference temperature
Short Time Overload	±(1.0% + 0.05Ω)	JIS-C-5201-1 4.13 IEC-60115-1 4.13 RCWV*2.5 or Max. Overload Voltage whichever is lower or 5 seconds
Insulation Resistance	≥10G	JIS-C-5201-1 4.6 IEC-60115-1 4.6 Max. Overload Voltage for 1 minute
Endurance	±(1.0% + 0.05Ω)	JIS-C-5201-1 4.25 IEC-60115-1 4.25.1 70±2°C, RCWV for 1000 hrs with 1.5 hrs "ON" and 0.5 hr "OFF"
Damp Heat with Load	±(0.5% + 0.05Ω)	JIS-C-5201-1 4.24 IEC-60115-1 4.24 40±2°C, 90~95% R.H., RCWV for 1000hrs with 1.5hrs "ON" and 0.5 hr "OFF"
Dry Heat	±(0.5% + 0.05Ω)	JIS-C-5201-1 4.23 IEC-60115-1 4.23.2 AT +155°C for 1000 hrs
Bending Strength	±(1.0% + 0.05Ω)	JIS-C-5201-1 4.33 IEC-60115-1 4.33 Bending once for 5 seconds 2010, 2512 sizes: 2mm Other sizes 3mm
Solderability	95% min. coverage	JIS-C-5201-1 4.17 IEC-60115-1 4.17 245±5°C for 3 seconds
Resistance to Soldering Heat	±(0.5% + 0.05Ω)	JIS-C-5201-1 4.18 IEC-60115-1 4.18 260±5°C for 10 seconds
Voltage Proof	No breakdown or flashover	JIS-C-5201-1 4.7 IEC-60115-1 4.7 1.42 times Max. Operating Voltage for 1 minute
Leaching	Individual leaching area ≤5% Total leaching area ≤10%	JIS-C-5201-1 4.18 IEC-60068-2-58 8.2.1 260±5°C for 30 seconds
Rapid Change of Temperature	±(0.5% + 0.05Ω)	JIS-C-5201-1 4.19 IEC-60115-1 4.19 -55°C TO +155°C, 5 cycles

RCWV (Rated Continuous Working Voltage) $-\sqrt{(P \cdot R)}$ or Max. Operating Voltage whichever is lower.

- Storage Temperature: 15 ~ 28°C; Humidity <80%RH

PACKAGING

- Reel Specifications & Packaging Quantity

TYPE	PACKAGING QUANTITY	TAPE WIDTH	REEL DIAMETER	ØA	ØB	ØC	W	T	
PWR06 PWR10 PWR12 PWR14	Paper	5K	8MM	7 INCH	178.5±1.5	60 ^{+1/0}	13.0±0.2	9.0±0.5	12.5±0.5
PWR20 PWR25	Em-bossed	4K	12MM	7 INCH	178.5±1.5	60 ^{+1/0}	13.0±0.5	13.0±0.5	15.5±0.5

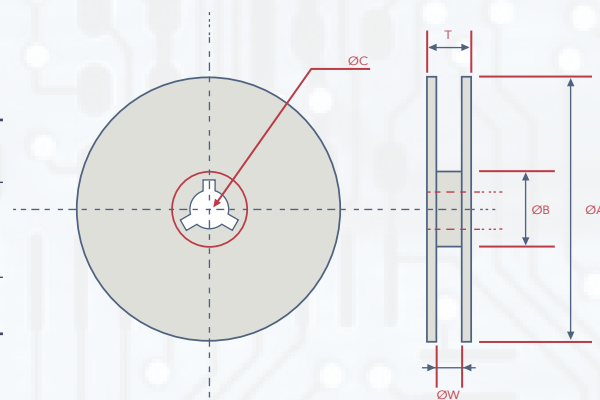

PACKAGING

- Paper Tape Specifications

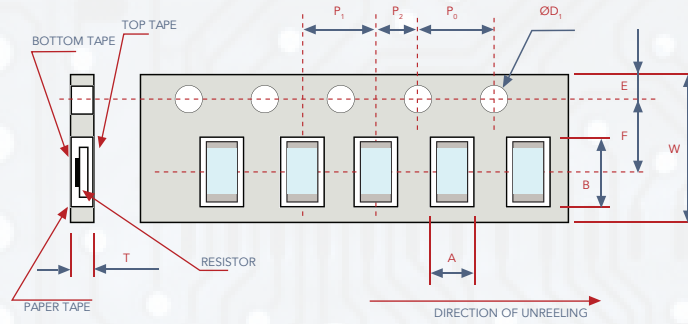

TYPE	A	B	W	E	F	P ₀	P ₁	P ₂	ØD ₀	T
PWR06	1.10 ± 0.10	1.90 ± 0.1	8.0 ± 0.2	1.75 ± 0.1	3.50 ± 0.05	4.00 ± 0.10	4.00 ± 0.05	2.00 ± 0.05	1.50+0.1, -0	0.70 ± 0.1
PWR10	1.60 ± 0.10	2.40 ± 0.2								0.85 ± 0.1
PWR12	1.90 ± 0.10	3.50 ± 0.2	8.0 ± 0.2	1.75 ± 0.1	3.50 ± 0.05	4.00 ± 0.10	4.00 ± 0.05	2.00 ± 0.05	1.50+0.1, -0	0.85 ± 0.1
PWR14	2.90 ± 0.10									

- Embossed Plastic Tape Specifications

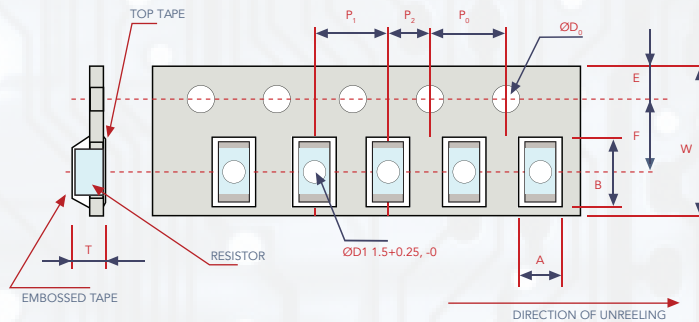

TYPE	A	B	W	E	F	P ₀	P ₁	P ₂	ØD ₀	T
PWR20	2.80 ± 0.10	5.5 ± 0.10	12.0 ± 0.3	1.75 ± 0.1	5.5 ± 0.05	4.00 ± 0.10	4.00 ± 0.1	2.00 ± 0.05	1.50 + 0.1, -0	1.2 ⁺⁰
PWR25	3.50 ± 0.10	6.7 ± 0.10								

MARKING

- 0805 - 2512 - 4 digits marking for example

RESISTANCE	100Ω	2.2KΩ	10KΩ	49.9KΩ	100KΩ	1MΩ
MARKING	1000	2201	1002	4992	1003	1004

- 0603 - 3 digits marking in E24

EXAMPLE: 101-100Ω | 102-1KΩ (1st and 2nd are E24 code and 3rd code is multiplier)

E24 CODE	10	11	12	13	15	16	18	20	22	24	27	30	33	36	39	43	47	51	56	62	68	75	82	91
----------	----	----	----	----	----	----	----	----	----	----	----	----	----	----	----	----	----	----	----	----	----	----	----	----

- 1% for 0603 - 3 digits marking in E96 (E96 series except E24 series)



- digits marking for Example: 13C - 13K3Ω | 68B - 4K99Ω | 68X - 49.9Ω



MARKING TABLE

CODE	E96	CODE	E96	CODE	E96	CODE	E96		
02	102	28	191	52	340	75	590		
03	105	29	196	53	348	76	604		
04	107	31	205	54	357	77	619		
06	113	32	210	55	365	78	634		
07	115	33	215	56	374	79	649		
08	118	34	221	57	383	80	665		
09	121	35	226	58	392	81	681		
10	124	36	232	59	402	82	698		
11	127	37	237	60	412	83	715		
13	133	38	243	61	422	84	732		
14	137	39	249	62	432	86	768		
15	140	40	255	63	442	87	787		
16	143	41	261	64	453	88	806		
17	147	42	267	65	464	89	825		
19	154	43	274	66	475	90	845		
20	158	44	280	67	487	91	866		
21	162	45	287	68	499	92	887		
22	165	46	294	69	511	93	909		
23	169	47	301	70	523	94	931		
24	174	48	309	71	536	95	953		
25	178	49	316	72	549	96	976		
26	182	50	324	73	562				
27	187	51	332	74	576				
CODE	A	B	C	D	E	F	G	X	Y
MULTIPLIER	10 ⁰	10 ¹	10 ²	10 ³	10 ⁴	10 ⁵	10 ⁶	10 ¹	10 ²

RECOMMEND LAND PATTERN

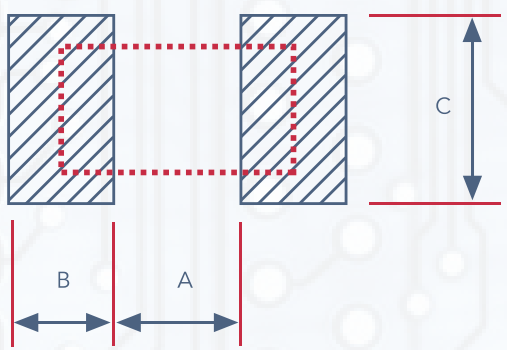

TYPE	A (MM)	B (MM)	C (MM)
PWR06	0.90	0.60	0.90
PWR10	1.20	0.70	1.30
PWR12	2.00	0.90	1.60
PWR14	2.00	0.90	2.80
PWR20	3.80	0.90	2.80
PWR25	4.90	1.00	3.40

LIGHTNING SURGE

- Resistors are tested in accordance with IEC 60115-1 using both 1.2/50 us and 10/700 pulse shapes. The limit of acceptance is a shift in resistance of less than 1% from the initial value.

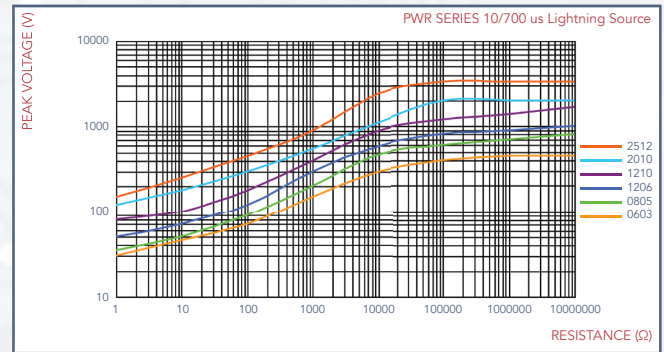
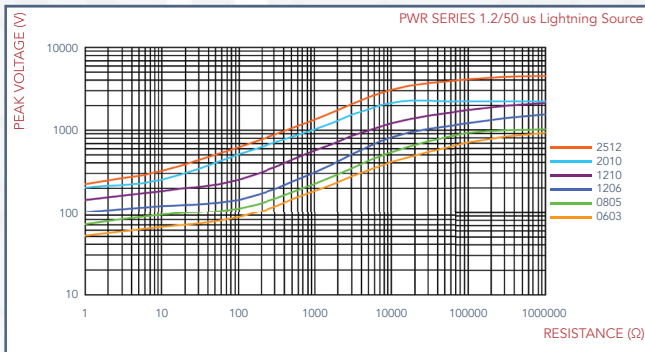

PULSE WITHSTANDING CAPACITY

- The single impulse graph is the result of 50 impulses of rectangular shape applied at one-minute intervals. The limit of acceptance was a shift in resistance of less than 1% from the initial value. The power applied was subject to the restrictions of the maximum permissible impulse voltage graph shown.

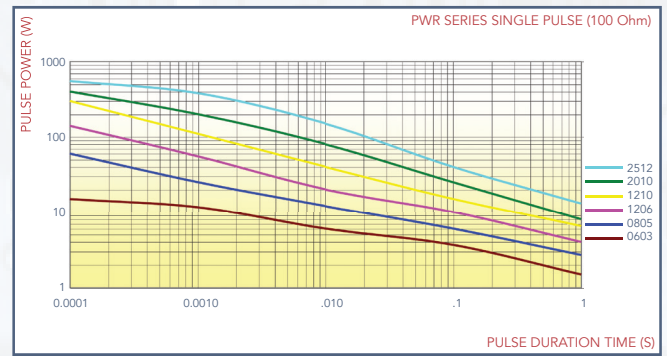

CONTINUOUS PULSE

- The continuous load graph was obtained by applying repetitive rectangular pulses where the pulse period was adjusted so that the average power dissipated in the resistor was equal to its rated power at 70°C. Again the limit acceptance was a shift in resistance of less than 1% from the initial value.

