

AUTOMOTIVE GRADE ANTI-SULFURATED CHIP RESISTOR - CAS SERIES -

FEATURES

- Special construction to prevent sulfuration in a sulfur containing environment
- AEC-Q200 Compliance

APPLICATIONS

- Automotive
- High-end Computer
- Industrial Equipment
- Automatic Equipment Controller
- Medical Equipment
- High-end Multimedia Electronics
- Outdoor Electronic Applications



PART NUMBERING GUIDE

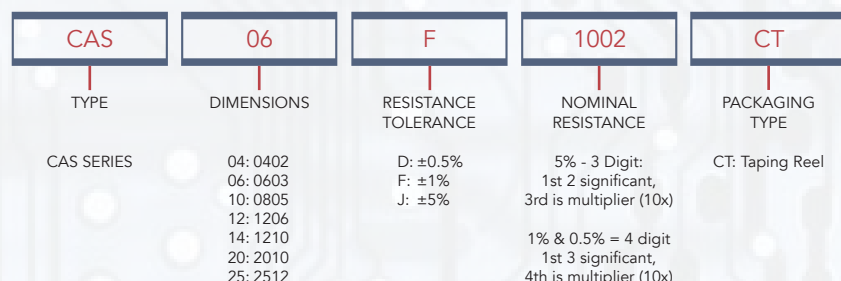

CONSTRUCTION

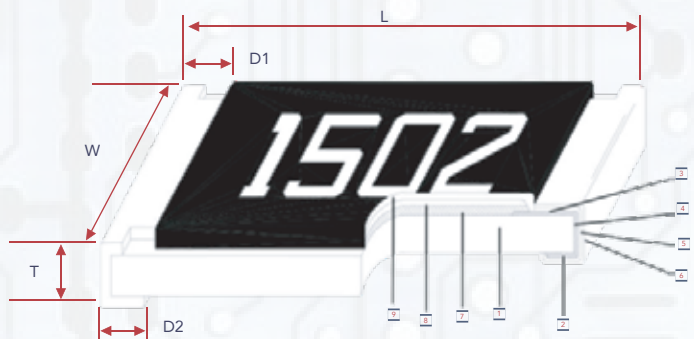

TYPE	SIZE INCH	L	W	T	D1	D2	WEIGHT (G) (1000 PCS)
CAS04	0402	1.00 ± 0.05	0.50 ± 0.05	0.35 ± 0.05	0.20 ± 0.10	0.20 ± 0.10	0.620
CAS06	0603	1.60 ± 0.10	0.80 ± 0.10	0.45 ± 0.10	0.30 ± 0.20	0.30 ± 0.20	2.042
CAS10	0805	2.00 ± 0.10	1.25 ± 0.10	0.55 ± 0.10	0.35 ± 0.20	0.40 ± 0.20	4.368
CAS12	1206	3.10 ± 0.10	1.55 ± 0.10		0.50 ± 0.25	0.50 ± 0.20	8.947
CAS14	1210	3.10 ± 0.10	2.60 ± 0.15		0.60 ± 0.25		15.959
CAS20	2010	5.00 ± 0.10	2.50 ± 0.15	0.60 ± 0.25	0.50 ± 0.20	24.241	
CAS25	2512	6.35 ± 0.10	3.10 ± 0.15			39.448	

- | | | |
|-------------------------|---------------------------|------------------------------|
| 1 Alumina Substrate | 4 Edge Electrode (NiCr) | 7 Resistor Layer |
| 2 Bottom Electrode (Ag) | 5 Barrier Layer (Ni) | 8 Primary Overcoat (glass) |
| 3 Top Electrode (Ag-pd) | 6 External Electrode (Sn) | 9 Secondary Overcoat (Epoxy) |



DERATING CURVE

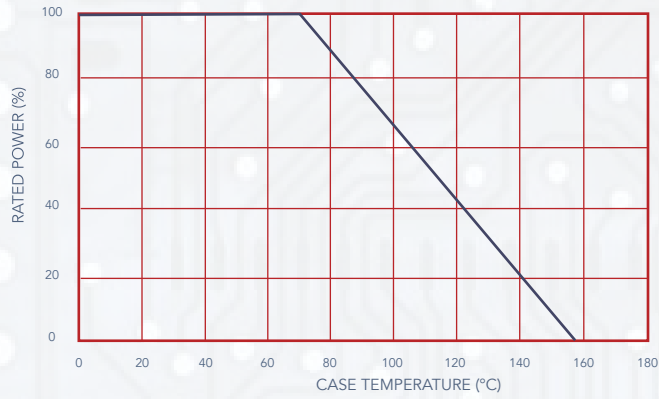

ELECTRICAL SPECIFICATIONS

TYPE	POWER RATING AT 70°C	OPERATING TEMP. RANGE	MAX OPERATING VOLTAGE	MAX OVERLOAD VOLTAGE	RESISTANCE RANGE			T.C.R. (PPM / °C)
					±0.5%	±1%	±5%	
CAS04 (0402)	1/16 W	-55 ~ +155°C	50V	100V	1Ω ~ 9.76Ω	±200		
	Jumper: 1A				10Ω - 1MΩ	±100		
CAS06 (0603)	1/10 W		50V	100V	1.02MΩ - 10MΩ	±200		
	Jumper: 1A				0Ω (<50MΩ)	-		
CAS10 (0805)	1/8 W		150V	300V	1Ω ~ 9.76Ω	±200		
	Jumper: 2A				10Ω - 1MΩ	±100		
CAS12 (1206)	1/4 W		200V	400V	1.02MΩ - 10MΩ	±200		
	Jumper: 2A				0Ω (<50MΩ)	-		
CAS14 (1210)	1/3 W		200V	400V	1Ω ~ 9.76Ω	±200		
	Jumper: 2.5A				10Ω - 1MΩ	±100		
CAS20 (2020)	3/4 W	200V	400V	1.02MΩ - 10MΩ	±200			
	Jumper: 3.5A			0Ω (<50MΩ)	-			
CAS25 (2512)	1W	250V	500V	1Ω ~ 9.76Ω	±200			
	Jumper 4A			10Ω - 1MΩ	±100			
						1.02MΩ - 10MΩ	±200	
						0Ω (<50MΩ)	-	

Operating Voltage: $\sqrt{(P \cdot R)}$ or Max operating voltage listed above, whichever is lower
 Overload Voltage: $2.5 \sqrt{(P \cdot R)}$ or Max overload voltage listed above, whichever is lower

CalChip is capable of manufacturing the optional spec based on customer's requirement





ENVIRONMENTAL CHARACTERISTICS

ITEM	REQUIREMENT			TEST METHOD
	±1% AND BELOW	±5%	JUMPER	
Temperature Coefficient of Resistance (T.C.R.)	As Spec.			=55°C ~ +125°C, 25°C is the reference temperature
Short Time Overload	±(1.0% + 0.05Ω)	± (2.0% + 0.05Ω)	<50Ω	2.5 times RCWW or Max. overload voltage for 5 seconds
Insulation Resistance	≥10G			Max overland voltage for 1 minute
Endurance	± (2.0% + 0.10Ω)	± (3.0% + 0.10Ω)	<100mΩ	70 + 2°C, Max. working voltage for 1000 hrs with 1.5 hrs "ON" and 0.5 hrs "OFF"
Biased Humidity	± (2.0% + 0.10Ω)	± (3.0% + 0.10Ω)	<100mΩ	1000 hrs 85°C / 85%RH 10% of operating power
High Temperature Exposure	± (1.0% + 0.05Ω)	± (1.5% + 0.10Ω)	<50mΩ	at +155°C for 1000 hrs
Bending Strength	± (1.0% + 0.05Ω)	± (1.0% + 0.05Ω)	<50mΩ	Bending once for 5 seconds 2010, 2512 sizes: 2mm Other sizes: 3mm
Thermal Shock	± (0.5% + 0.05Ω)	± (1.0% + 0.05Ω)	<50mΩ	-55C / +155°C. Note: Number of cycles required - 300, Maximum transfer time - 20 seconds, Dwell time - 15 minutes. Air-Air
Solderability	95% min coverage			245 ± 5°C for 3 seconds
Resistance to Soldering Heat	± (0.5% + 0.05Ω)	± (1.0% + 0.05Ω)	<50mΩ	260 ± 5°C for 10 seconds
Voltage Proof	No breakdown or flasovert			1.42 times RCWW (RMS) for 1 minute
Leaching	Individual leaching area ≤5% Total leaching area ≤10%			260 ± 5°C for 30 seconds
Temperature Cycling	± (0.5% + 0.05Ω)	± (1.0% + 0.05Ω)	<50mΩ	-55°C to +125°C, 1000 cycles
Moisture Resistance	±(2.0% + 0.05Ω)	± (1.0% + 0.05Ω)	<50mΩ	24 hrs / cycle
Mechanical Shock	±(0.25% + 0.05Ω)	± (1.0% + 0.05Ω)	<50mΩ	Wave Form: Tolerance for half sine shock pulse. Peak vallue is 100g's. Normal duration (D) is 6.
Vibration	± (0.5% + 0.05Ω)	± (1.0% + 0.05Ω)	<50mΩ	5 g's for 20 min., 12 cycles each of 3 orientations, 10-2000Hz
ESD	± (1% + 0.05Ω)			Human body, 2KV
Flame Retardance	Not flame			Temperature sensing at 500°C, voltage power subjected to 32VDC current clamped up to 500ADC and decreased in 1.0VDC/Hour
Resistance to Solvents	Markign Unsmearad			Add Aqueous wash chemical - OKEM Clean or equivalent. Do not use banned solvents.
Terminal Strength	No broken			Force of 1.8kg for 60 seconds
Sulfur Test	ΔR ± 0.5%		<50mΩ	3~5ppm H2S, 50±2°C, 91~93% R.H., no power rating for 1000 hrs

Reference Standards - IEC60115-1, 60068-2-58; JIS-C 5201-1, 6429; ASTM-B-809; AEC-Q200; MIL-STD-202; JESD22
 Storage Temperature - 25±3°C; Humidity <80%RH

PACKAGING

Reel Specifications & Packaging Quantity

UNIT: MM									
TYPE	PACKAGING QUANTITY	TYPE WIDTH	REEL DIAMETER	ØA	ØB	ØC	W	T	
CAS04	Paper	10K	8mm	7 inch	178.5 ± 1.5	60 ^{+1/0}	13.0 ± 0.5	9.0 ± 0.5	12.5 ± 0.5
CAS06									
CAS10									
CAS12									
CAS14									
CAS20	Embossed	4K	12mm	7 inch	178.5 ± 1.5	60 ^{+1/0}	13.0 ± 0.5	13.0 ± 0.5	15.5 ± 0.5
CAS25									

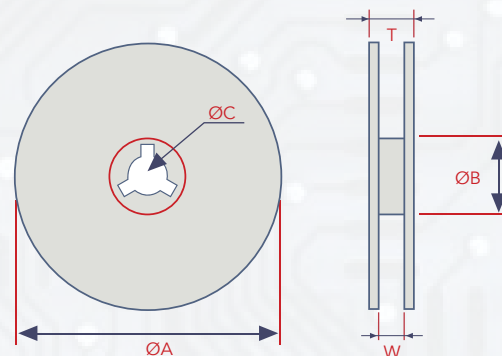

Paper Tape Specifications

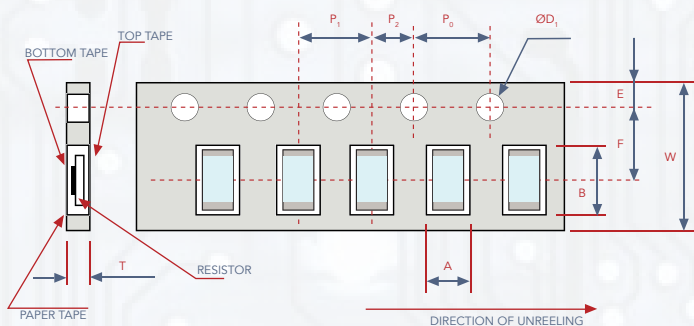

UNIT: MM											
TYPE	A	B	W	E	F	P ₀	P ₁	P ₂	ØD ₁	T	
CAS04	0.65±0.10	1.15±0.10	8.0±0.20	1.75±0.10	3.50±0.05	4.00±0.10	2.00±0.05		1.50+0.1,-0	0.45±0.10	
CAS06	1.10±0.10	1.90±0.10					4.00±0.05	2.00±0.05			0.70±0.10
CAS10	1.60±0.10	2.40±0.20									
CAS12	1.90±0.10	3.50±0.20									
CAS14	2.90±0.10	3.50±0.20									

Embossed Tape Specifications

TYPE	A	B	W	E	F	P ₀	P ₁	P ₂	ØD ₀	T
CAS20	2.8±0.10	5.5±0.10	12.0±0.30	1.75±0.10	5.5±0.05	4.00±0.10	4.00±0.10	2.00±0.05	1.50+0.1,-0	1.2 ^{±0}
CAS25	3.5±0.10	6.7±0.10								

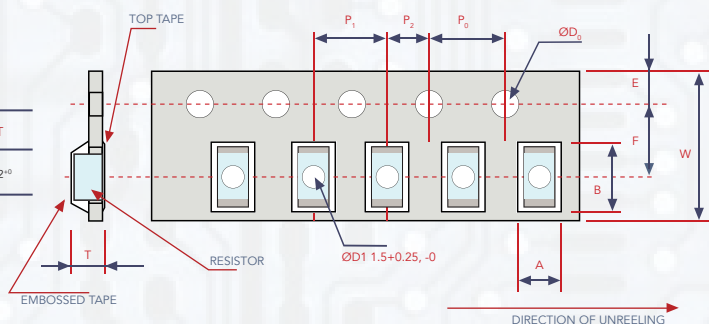

RECOMMENDED LAND PATTERN

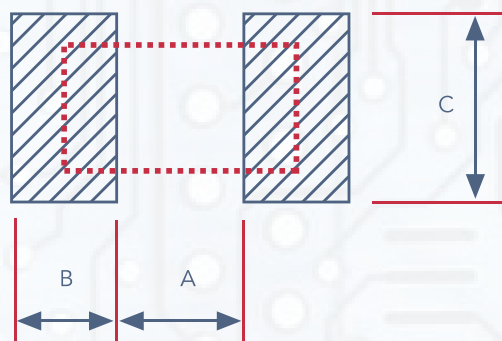

TYPE	A	B	C
CAS04	0.50	0.45	0.60
CAS06	0.90	0.60	0.90
CAS10	1.20	0.70	1.30
CAS12	2.00	0.90	1.60
CAS14	2.00	0.90	2.80
CAS20	3.80	0.90	2.80
CAS25	3.80	1.60	3.50

